

# 1800 SERIES

The **1800 Series Dual Disk Brake**, named for its **eighteen inch** diameter disks, offers high performance in a **torque range from 33 lb-inches up to 17,990 lb-inches**.

The 1800 Series Brake delivers the precise torque range needed for a particular application by allocating actuation of just the number of cylinders needed, from **one up to ten**.



## OPTIONS

- **Metric Mounting Bolt (MMB).** Metric mounting bolts for the actuators.
- **Non-Standard Key (NSK).** For shafts having a different sized key other than the standardized ones usually used.
- **Reduced Area Piston (RA).** Reduces torque produced to 31% of normal.

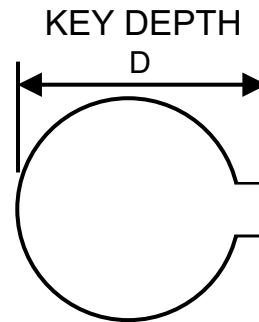

## ACCESSORIES

- **Mounting Plate** - Flat plate for mounting the brake and guard if used.
- **Guard** - Safety device to prevent people or objects from touching brake when in motion or hot.
- **Guard Blocks** - Allows installation of guard without mounting plate.
- **Valve Assembly** - Controls air supply for actuators.

## SPECIFICATIONS:

Disk/Hub Inertia	178.9 Slug-in <sup>2</sup>
Max. Torque	17,990 in-lbs
Disk/Hub Weight	172.8 lbs.
Max. Ship Wt.	236 lbs.
Min. Shaft Length	9.2 in.

TORQUE CAPACITY, LB-IN (N-M)				
Torque Capacity at 75psi (5.17 bar)				
BRAKE SIZE		PAD COEFFICIENT OF FRICTION		
SERIES	# OF CYLINDERS	0.10 (#1) LB-IN (N-M)	0.20 (#2) LB-IN (N-M)	0.45 (#4) LB-IN (N-M)
1800	1	400 (45)	790 (89)	1800 (203)
	2	800 (90)	1590 (180)	3600 (407)
	3	1200 (136)	2400 (271)	5400 (610)
	4	1600 (181)	3190 (360)	7200 (813)
	5	2000 (226)	3990 (451)	9000 (1016)
	6	2400 (271)	4800 (542)	10800 (1220)
	7	2800 (316)	5590 (632)	12590 (1422)
	8	3200 (362)	6390 (722)	14390 (1626)
	9	3600 (407)	7200 (813)	16190 (1829)
	10	3990 (451)	7990 (903)	17990 (2033)

1800 SERIES	STANDARD HUB BORE AND KEY DIMENSIONS					
	ENGLISH			METRIC		
	BORE	KEY	DEPTH (D)	BORE	KEY	DEPTH (D)
	2.000	1/2	2.223	50	14	53.8
	2.063	1/2	2.287	52	16	56.3
	2.125	1/2	2.350	55	16	59.3
	2.188	1/2	2.414	58	16	62.3
	2.250	1/2	2.477	60	18	64.4
	2.313	5/8	2.587	62	18	66.4
	2.375	5/8	2.651	65	18	69.4
	2.438	5/8	2.714	68	20	72.9
	2.500	5/8	2.778	70	20	74.9
	2.563	5/8	2.841	72	20	76.9
	2.625	5/8	2.905	75	20	79.9
	2.688	5/8	2.968	78	22	83.4
	2.750	5/8	3.032	80	22	85.4
	2.813	3/4	3.142	82	22	87.4
	2.875	3/4	3.205	85	22	90.4
	2.938	3/4	3.269	88	25	93.4
	3.000	3/4	3.332	90	25	95.4
	3.063	3/4	3.396	92	25	97.4
	3.125	3/4	3.459	95	25	100.4
	3.188	3/4	3.523	98	28	104.4
	3.250	3/4	3.586	100	28	106.4
	3.313	7/8	3.696	102	28	108.4
	3.375	7/8	3.760	105	28	111.4
	3.438	7/8	3.823	108	28	114.4
	3.500	7/8	3.887	110	28	116.4
	3.563	7/8	3.950	115	32	122.4
	3.625	7/8	4.014			
	3.688	7/8	4.077			
	3.750	7/8	4.141			
	3.813	1	4.251			
	3.875	1	4.314			
	3.938	1	4.378			
	4.000	1	4.441			

**1800 SERIES DIMENSIONS (Model 1810 shown)**  
 inches (mm)

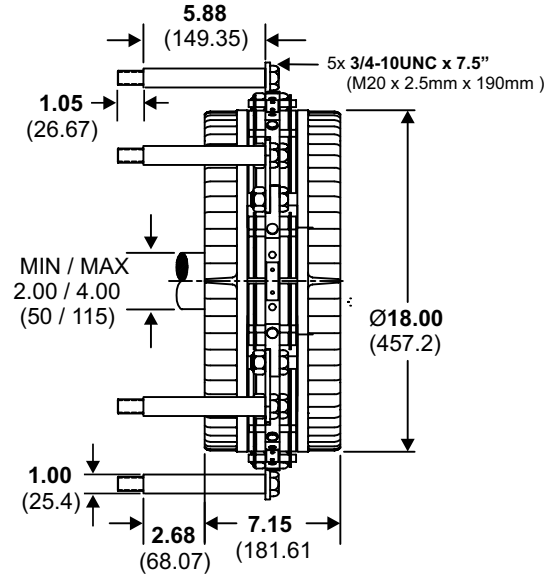
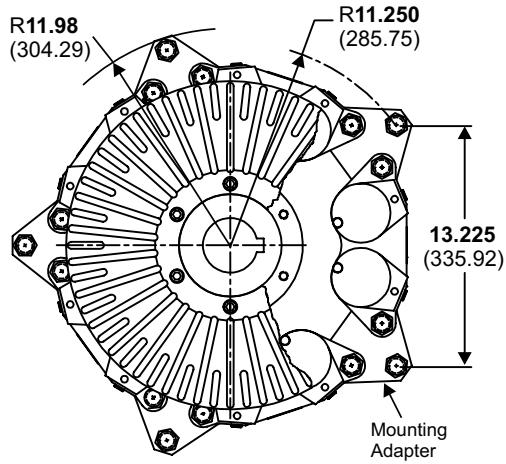

**MOUNTING PLATE DIMENSIONS (Accessory)**  
 inches (mm)

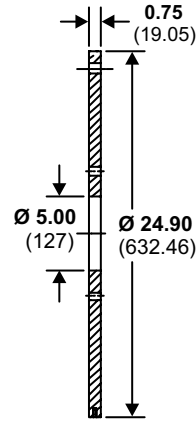
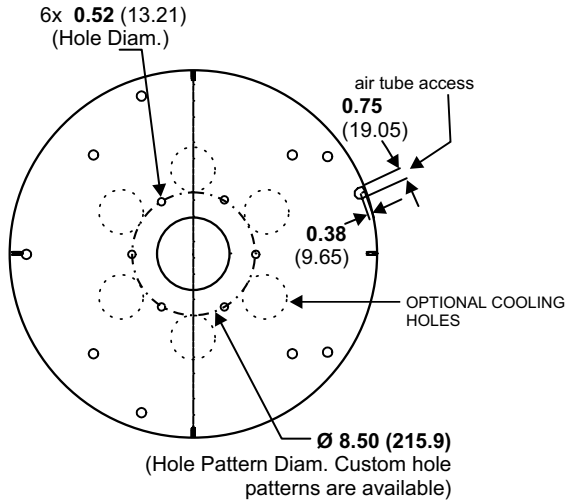

**BRAKE GUARD DIMENSIONS (Accessory)**  
 inches (mm)

THRU-SHAFT HOLE 4.63 (117.60) Diam.  
 REQUIRES REMOVAL OF NAME PLATE

