

TENSION ROLL[®] TRANSDUCER SPECIFICATION

(Please return to or fax to DFE)

COMPANY _____ PREPARED BY _____

ADDRESS _____ TELEPHONE _____

CITY _____ STATE _____ ZIP _____ DATE _____

A. ROLL AND SHAFT CONFIGURATION

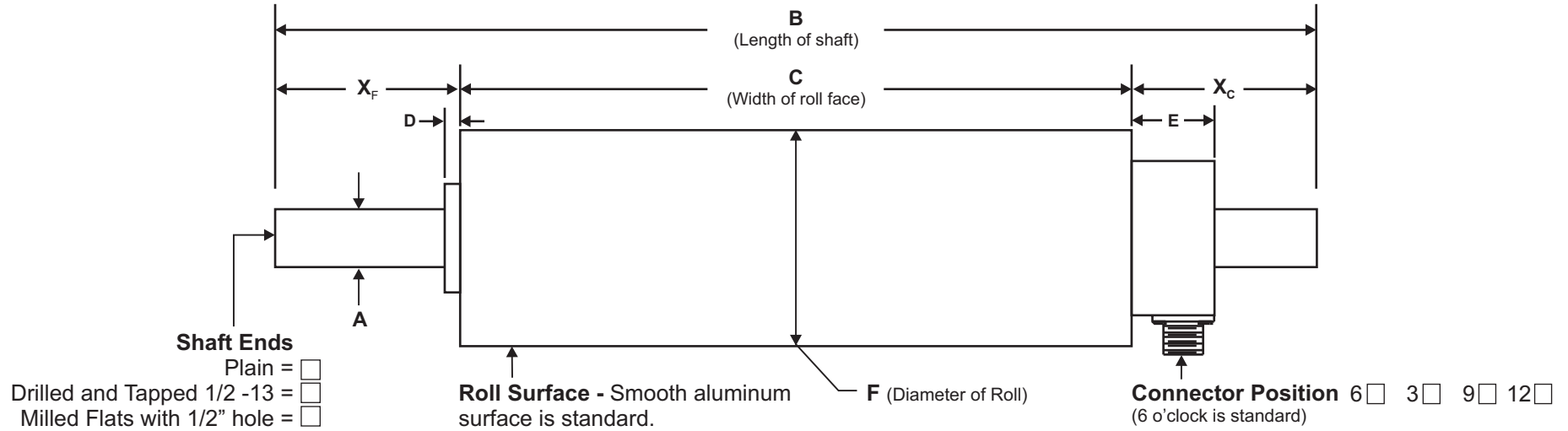

SIZE	MINIMUM		A	D	E	STANDARD F
	X _F	X _C				
1	0.43	1.25	0.75	0.31	1.12	3.00
2	0.43	1.62	1.125	0.31	1.50	4.00

Roll will be built with X_C = X_F (roll centered on shaft) unless specified otherwise

B = _____ Shaft
 C = _____ Roll (see Note 3)
 F = _____ Dia.
 X_F = _____
 X_C = _____
 Roll material _____
 Roll surface _____
 Load Rating _____

OPTIONS	ACCESSORIES

B. WEB CHARACTERISTICS

- Total Web Tension, Max. _____ Min. _____ pounds (if known)
- Type of Web Material _____ • Width: Max. _____ Min. _____ inches
- Basis Weight or Thickness _____ • Max. Web Speed _____ FPM

NOTE: If more than one material is used, give information for the two requiring the most and least tension.

C. SPECIAL FEATURES: _____

over....

D. LOAD RATING CALCULATION

Cross out the wraps that don't apply

WRAP 1

Tension Force F_T , **above** horizontal

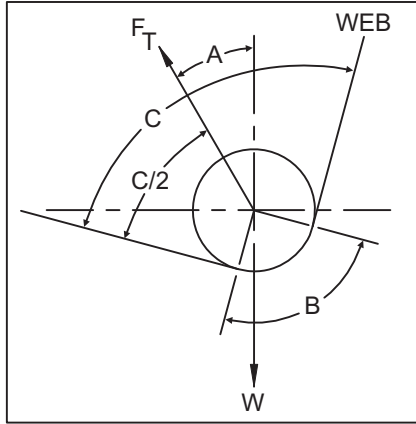

$$\text{LOAD RATING} = \frac{4T \sin\left(\frac{B}{2}\right) - W \cos(A)}{2}$$

WRAP 2

Tension Force F_T , **below** horizontal

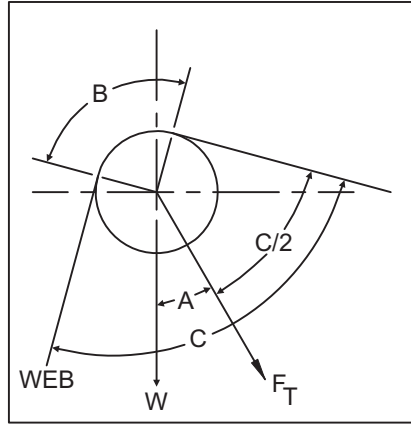

$$\text{LOAD RATING} = \frac{4T \sin\left(\frac{B}{2}\right) + W \cos(A)}{2}$$

WRAP 3

Tension Force F_T , **is** horizontal

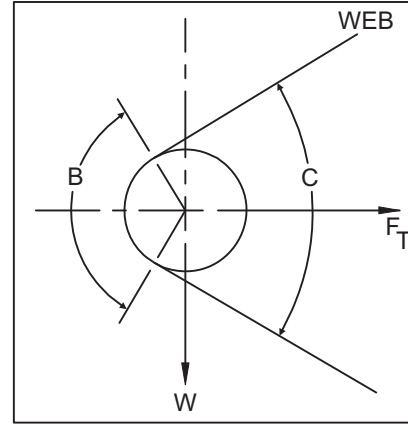

$$\text{LOAD RATING} = \frac{4T \sin\left(\frac{B}{2}\right)}{2}$$

W = roll assembly weight, T = Maximum web tension, B = Wrap angle = $180^\circ - C^\circ$, A = Angle between Tension Force F_T and vertical

STANDARD LOAD RATINGS ARE: **Size 1** = 12, 25, 50, 100, 150 lbs
Size 2 = 12, 25, 50, 100, 200, 400 lbs.

TABLE 1

Angle (Degrees)	SINE	COSINE
0	.000	1.000
5	.087	.996
10	.174	.985
15	.259	.966
20	.342	.940
25	.423	.906
30	.500	.866
35	.574	.819
40	.643	.766
45	.707	.707
50	.766	.643
55	.819	.574
60	.866	.500
65	.906	.423
70	.940	.342
75	.966	.259
80	.985	.174
85	.996	.087
90	1.000	.000

Value of W for Aluminum Rolls (lbs.)

	ROLL DIAMETER	FORMULA
SIZE 1	3 inch	$W = 1.4 + 0.30 \times C$
	4 inch	$W = 4.3 + 0.54 \times C$
SIZE 2	5 inch	$W = 4.3 + 0.69 \times C$
	6 inch	$W = 4.3 + 0.85 \times C$

E. ANGLES AND ROLL WEIGHT

Record information in boxes. If you do not know wrap angle, be sure to give Angle "C".

W = roll weight pounds

B = wrap angle degrees

F_T = force on idler roll due to web tension. F_T is in the same direction as the arrow on the transducer.

A = angle between F_T and vertical axis degrees

C = angle between entering and exiting web degrees

C = face width of roll (inches). Refer to Note 3 for other roll materials

NOTES: 1. Any covering applied to the roll will affect the load rating calculation.

2. Consult factory for sizing of units with steel or stainless steel rolls.

3. Refer to the TR Transducer data sheets for length limitations, W formulas, options, and accessories