

MODEL VNW TENSION TRANSDUCER

The VNW (Very Narrow Web) transducer is a compact tension-sensing device for measuring process tension in narrow web (up to six inches wide), ribbon or filament. The VNW transducer combines the robust and versatile design of DFE's time-proven shaft-end transducers with a choice of mounting styles and wheel options from the RFA-style cantilevered transducers. DFE has kept the quality of the VNW transducer high while offering it at a low base price.

A VNW transducer is cantilever-mounted on process machinery for unwind/ payoff, rewind/ take-up, or intermediate zone applications. Tension is measured by high-output silicon strain gages housed internally on a dual cantilevered transducer beam and connected in a wheatstone bridge configuration. As the ribbon or filament passes over the roller or pulley wheel, the force of the substrate on the shaft causes a minute deflection of the transducer beam. The resulting change in strain gage resistance yields a voltage output from the transducer that is proportional to tension. The transducer output is then amplified by a DFE indicator or automatic controller for tension measurement or complete closed-loop tension control.

The VNW transducer has an aluminum beam with a stainless steel housing and shaft holder. The five mounting styles offered are single bolt (with an alternative to face-mount the transducer on the outside of the machine frame using a bolt pattern on the transducer front), flange, pillow block, piloted flange, or through-frame. These options are pictured at the right.

Available Mounting Styles



All wheels (or rollers) are optional accessories; no wheel is provided as standard since many customers prefer to supply their own shafts and wheels. Wheels are shaft-mounted with the shaft inserted into the transducer's face coupling and secured by set screws. The shaft insertion depth can be adjusted (+/- 0.25 inch) for proper alignment of the wheel with the web. On the standard unit the electrical connector is positioned at 6 o'clock (same as the tension force direction).

BENEFITS/FEATURES

- 2.125" depth allows for installation in tight spaces.
- Transducer mounts to machine frame from either side.
- Circular profile allows for easy rotation of housing for maximum beam sensitivity.
- Dual cantilever beam provides high strength and accuracy even at low tension.
- Tension-Freesm 5-Year Warranty

- Shaft position can be adjusted inward or outward +/- 0.25" and then locked in place using set screws.
- Stainless steel and aluminum construction for excellent corrosion resistance.
- All mounting styles can be rotated to any position for precise orientation.

OPTIONS

- **Environmental Connector (EC)** - Seals with mating cable electrical connector to protect against contact oxidation; especially useful in corrosive environments.
- **Extended Range Output (XR)** - Extra sensitive to low tensions. XR produces twice the output signal for a given load rating. This increases the signal to noise ratio. It is used in applications requiring a full scale tension force that is as low as 6% of the transducer load rating. 12% is standard. Extended range (XRE) is required for the mating electronic unit.
- **Metric Mounting Stud (MMS)** - Metric mounting screw for S type transducers.

ACCESSORIES

- **Wheel Assemblies:** Hardcoat Aluminum wheels available in 3 types: **Ribbon Wheels:** Available in widths from 1" to 6" (in one inch increments); **Filament Wheel:** For filament webs; **Adapter Wheel:** For custom requirements.
- **Shaft Assembly:** No wheel, thru-bolt and spacer with two bearings.

PRODUCT CODE

You may order by description or by specifying the code by matching each labeled place with one of the choices below.

EXAMPLE: VNW 2 - S - 10 - 12 - EC,XR

SIZE MOUNTING LOAD CONNECTOR OPTIONS
 STYLE RATING POSITION

SIZE	MOUNTING STYLE	LOAD RATING	CONNECTOR POSITION	OPTIONS
2	S = Screw / Bolt PB = Pillow Block FL = Flange TF = Through-frame PFL = Piloted Flange	10 lbs. 25 lbs. 50 lbs. 100 lbs. 200 lbs. 400 lbs.	6 (6:00) Std. 12 (12:00) Rear (PB, TF ² , PFL only)	D & T = Non-standard Drill and Tap EC = Environmental Connector XR = Extended Range ¹ MMS = Metric Mounting Stud Z = Special (SPR)

1. Requires that indicator/controller has XRE option.
 2. Must use rear connector position for TF style.

SPECIFICATIONS:

ELECTRICAL

Excitation: 5 Vdc, regulated (10Vdc with XR)
Output: 500mVdc at 5V excitation
 (1000mVdc at 10V excitation with XR)
Strain Gage Resistance: 100 ohms, nominal
Non-Repeatability: ±1/4% Full Span (FS)
Combined Non-Linearity and Hysteresis: ±1/2% (FS)
Temperature range: -10°F to 200°F (-23°F to 93°C)
Temperature Coefficient: 0.02% FS per °F, typical
 (0.036% FS per °C)
Mating Electrical Connector: Bendix PT06E10-6S
Connector Pin Assignment:
 A = negative output D = positive output
 B = +5V E = -5V
 C = -5V F = +5V
Circuit Configuration: Full Wheatstone Bridge

MECHANICAL

Overload Capacity:
 1200 lbs. (5338 N)
Deflection of Sensor Beam: 0.005 in. max. (0.127 mm)
Material: 6061, 7075-T6 Aluminum;
 303, 304 Stainless Steel
Connector Position (standard):
 Screw, Flange, and Piloted Flange mount = 6 o'clock
 (connector points in tension force direction)
 Pillow Block and Through Frame = center rear
Load Ratings: 10, 25, 50, 100, 200, 400 lbs.
 (44, 111, 222, 445, 890, 1779 N)
Optional Wheel Weights:
 Filament = 0.49 lbs. (222g)
 Ribbon = 0.45 lbs. (204 g)
 Adapter = 0.65 lbs. (295g)

SELECTION OF LOAD RATING

The correct transducer load rating for your application is determined by maximum web tension, wrap angle, and roller weight. Choose the appropriate wrap configuration from the diagrams below. Then compute the Net Force using the formula below the diagram. (The direction of the tension force determines which diagram and formula to use).

The selected load rating, may be 20% less than the computed Net Force. The actual force on the transducer will read 125% of the load rating before hitting the stops. This is acceptable because the Net Force formula contains an oversizing factor of 2, which means that the actual force exerted on the transducer will not exceed its rating.

Sometimes, the roller is so heavy that its weight uses up most of the operating range of the transducer. When this happens, it may not be possible to adjust the tension indicating meter to read zero when tension is zero because the adjustment range of the electronic circuit has been exceeded. To find out if the roller is

too heavy, compare the load rating with the effective weight of the roller as follows: The effective roller weight is the "WCOS(A)" term in the formula. If WCOS(A) is more than 95% of the load rating chosen, the tension meter will probably not be adjustable to zero. If this is the case, one or more of the following changes must be made to reduce WCOS(A) to less than 95% of the load rating:

1. Reduce the transducer roller or wheel weight
2. Increase angle (A)
3. Use the next higher load rating (This is the least desirable choice because it reduces transducer signal output).

WRAP 1

Tension Force F_T above horizontal

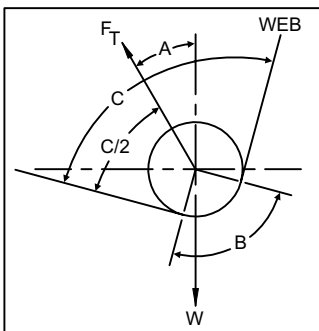

$$\text{NET FORCE} = 4T \sin\left(\frac{B}{2}\right) - W \cos(A)$$

W = Wheel weight (See Note below)
 B = Wrap angle = $180^\circ - C^\circ$

WRAP 2

Tension Force F_T below horizontal

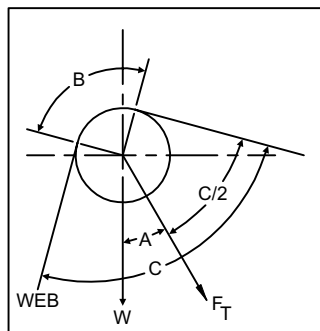

$$\text{NET FORCE} = 4T \sin\left(\frac{B}{2}\right) + W \cos(A)$$

T = Maximum web tension
 A = Angle between Tension Force F_T and vertical

WRAP 3

Tension Force F_T is horizontal

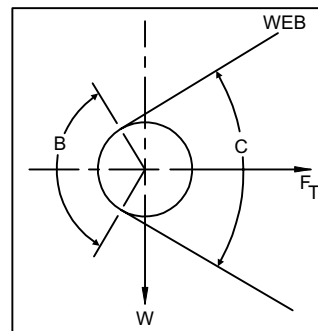

$$\text{NET FORCE} = 4T \sin\left(\frac{B}{2}\right)$$

TABLE 1

Angle (Degrees)	SINE	COSINE
0	.000	1.000
5	.087	.996
10	.174	.985
15	.259	.966
20	.342	.940
25	.423	.906
30	.500	.866
35	.574	.819
40	.643	.766
45	.707	.707
50	.766	.643
55	.819	.574
60	.866	.500
65	.906	.423
70	.940	.342
75	.966	.259
80	.985	.174
85	.996	.087
90	1.000	.000

NOTE: Weight of standard filament wheel is 0.49 lbs. (222 grams) including bearings and fasteners
 Weight of standard ribbon wheel is 0.45 lbs. (204 grams) including bearings and fasteners
 Weight of standard adapter wheel is 0.65 lbs. (295 grams) including bearings and fasteners.
 Weight of customer supplied wheel must be provided and is subject to DFE engineering approval.

Note: These sizing formulas contain an oversizing factor of 2X tension to account for tension surges.

DIMENSIONS

Inches (mm)

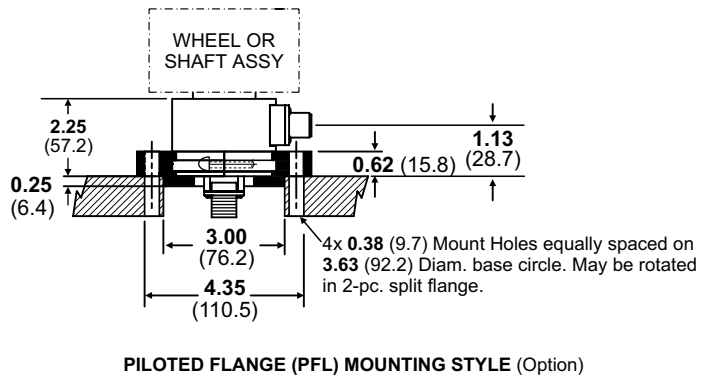
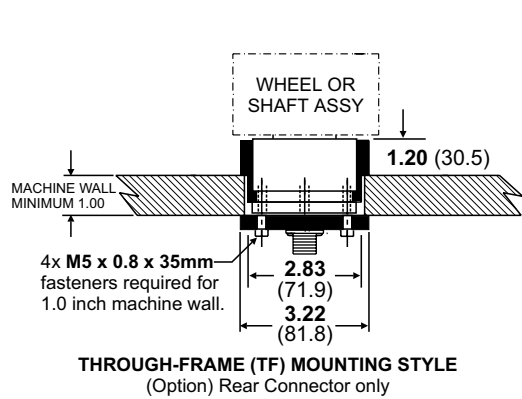
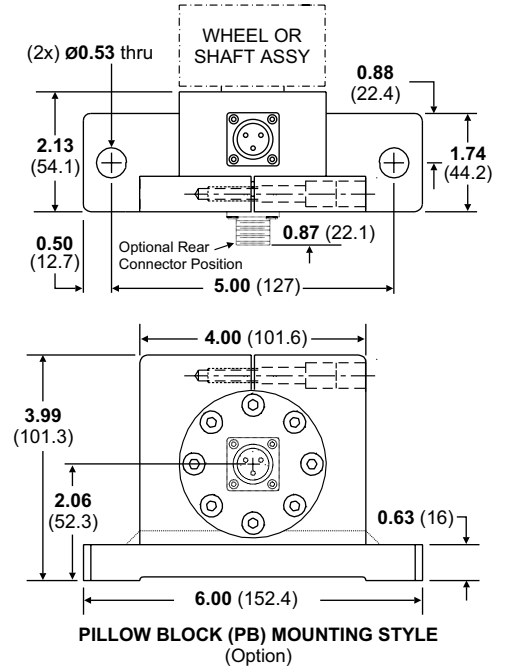
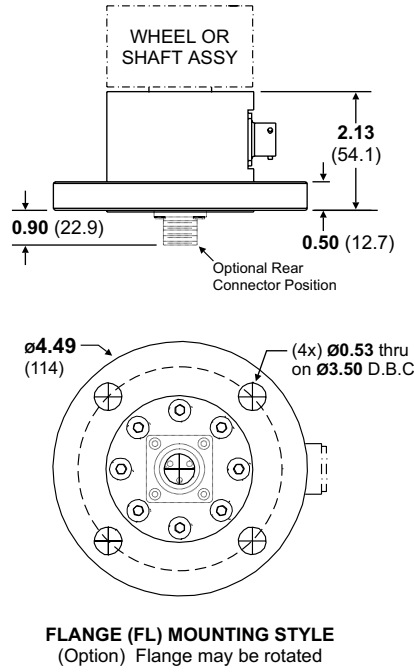
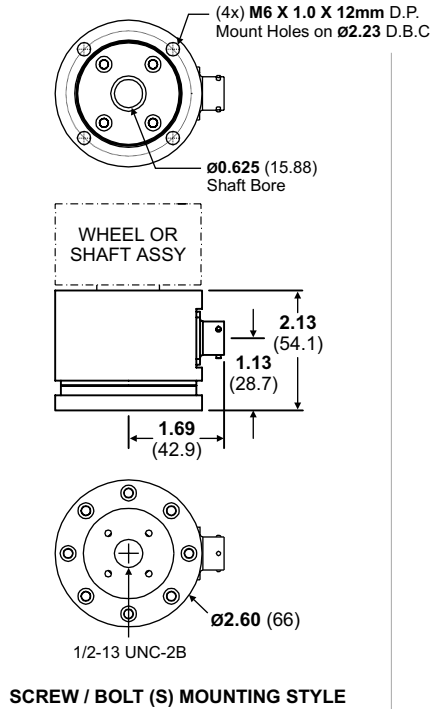

ACCESSORY WHEEL DIMENSIONS

Inches (mm)

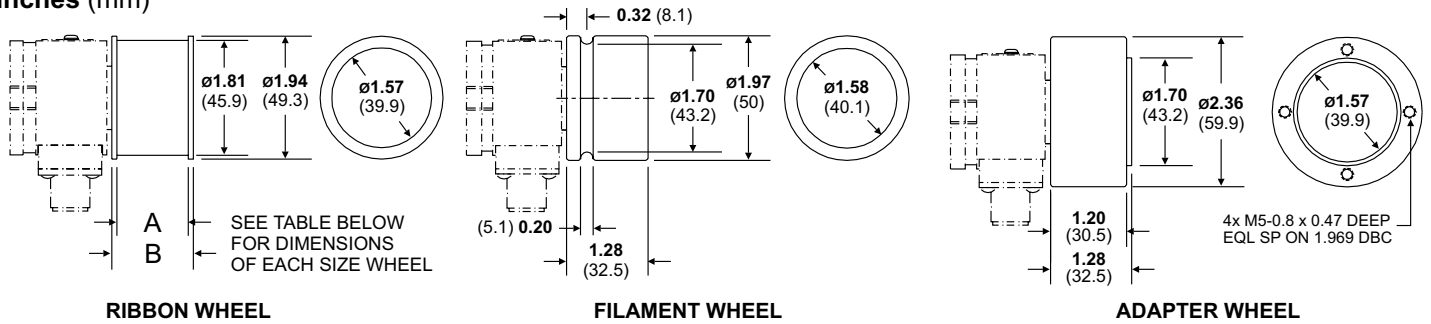

		RIBBON WHEEL SIZES					
		1	2	3	4	5	6
A	in.	1.13	2.13	3.13	4.13	5.13	6.13
	mm	28.7	54.1	79.5	104.9	130.3	155.7
B	in.	1.28	2.28	3.28	4.28	5.28	6.28
	mm	32.5	57.9	83.3	108.7	134.1	159.5