

MODEL LT Low Tension Transducer

The Model "LT" Low Tension Transducer is an electro-mechanical sensor device that converts filament or web tension into a D.C. voltage proportional to tension. The voltage output can be amplified in external electronic circuitry and displayed as actual tension on an analog or digital meter. Filament tension can be displayed accurately in pounds, ounces, grams, kilograms, newtons or other units. Transducer output can also be fed to a DFE automatic tension controller to control tension.

The Low Tension Transducer has been designed to measure very low tensions accurately in filaments and very narrow webs (ribbon). It is typically used as part of a tension control and display system on any machine which is processing, winding, or unwinding filaments, or very narrow webs. The LT Transducer is available in either a

stackable housing configuration or with threaded housing (M36 x 4) and two locking nuts. The threaded housing installs easily into a hole on your machine frame. Its locking nut system allows force direction to be changed by simply loosening the nuts and adjusting the transducer to a desired position.

The standard Low Tension Transducer wheels are lightweight, hard-coat, anodized aluminum. They are durable, and have low inertia. The bearings are instrument grade ball type with shields to prevent entry of contaminants. Custom wheel geometries and/or finishes are available and the transducer may even be purchased without the wheel, so the user can provide their own wheel.

BENEFITS

- Helps reduce waste and improve quality and productivity.
- Compact size allows transducer to fit into small spaces.
- Low cost.
- Ultra-low break-away torque (1.5 g-cm or 0.02 oz-inches) means no sliding or scratching of filament on wheel.
- Stackable. Several transducers fit into a small space.
- Two mounting styles to fit any application.
- Measures very low tension accurately.

OPTIONS

- **Environmental Connector (EC).** Internal connector components are protected from corrosive environmental conditions by special connector.
- **Non-Standard Wheels.** A Ribbon Wheel is available.
- **Non-Standard Wheel Finishes.**

FEATURES

- Six load ratings, from 50 grams to 2000 grams.
- Aluminum construction.
- Choice of filament wheel, ribbon wheel, or stationary pin.
- Two mounting styles, stackable or through-hole.
- High output provides resistance to electrical noise.
- Strong construction.
- Use with any DFE tension indicator or controller.

ACCESSORIES

- **Cables.** Transducer cables are available in lengths of 15, 20, 25, or 30 feet. Special lengths can also be ordered. Your DFE Applications Engineer will help you select the proper cable for your application.

ORDERING INFORMATION

You may order from description or by specifying the code below by matching each labeled digit with one of the choices given.

LT - S - 50 - F - OPTIONS (Separated by commas)

HOUSING	LOAD RATING	WHEEL	OPTIONS
S = Stackable T = Threaded	50 grams 100 grams 200 grams 500 grams 1000 grams 2000 grams	F = Filament R = Ribbon P = Pin N = No wheel Z = Custom	EC = Environmental Connector Z = Special

SPECIFICATIONS:

Excitation Voltage: 10Vdc

Output: 500mVdc nominal

Strain Gauges:

Semiconductor, 800 ohms nominal resistance

Non-Repeatability: ±1/2% full span (FS)

Non-Linearity and Hysteresis Combined: ±1/2% FS

Maximum Overload Capacity: 20 lbs (89 N)

Temperature Range: -10°F to 200°F (-23°C to 93°C)

Deflection: 0.20" typical (0.50mm typical)

Temperature Coefficient:

0.02% per degree F typical (0.01% per degree C typical)

Load Ratings: 50, 100, 200, 500, 1000, 2000, grams
(0.11, 0.22, 0.44, 1.10, 2.20, 4.40 lbs.)

Electrical Connector: Bendix PT02E-10-6P

Mating Electrical Connector: Bendix PT06E-10-6S

Connector Pin Assignments:

Pin A = negative output (WHT) Pin B = 10V+ (BLK)

Pin C = 10V- (RED)

Pin D = positive output (GRN)

Pin E = 10V- (BLU)

Pin F = 10V+ (BRN)

Break Away Torque: 0.02 oz-in (1.5 gram-cm) typical

Standard Connector Position: Rear Only

Basic Dynamic Load Rating of Bearings:

299 lbs. (1340 N)

Materials: Stainless Steel & Aluminum

SELECTION OF LOAD RATING:

The correct transducer load rating for your application is determined by maximum web tension, wrap angle, and wheel weight. Choose the appropriate wrap configuration from the diagrams below. Then compute the Net Force using the formula below the diagram.

In some cases the load rating may be less than the computed Net Force. This may be acceptable because the Net Force formula contains an oversizing factor of 2, which means that the actual force exerted on the transducer will not exceed its rating.

The following applies only to non-standard wheels or other hardware used in place of the wheel:

Sometimes a wheel is so heavy that its weight uses up most of the operating range of the transducer. When this happens, it may not be possible to adjust the tension indicating meter to read zero when tension is zero because

the adjustment range of the electronic circuit has been exceeded. To find out if the wheel is too heavy, compare the load rating with the effective weight of the wheel as follows: The effective wheel weight is the "W COS (A)" term in the formula. If W COS (A) is more than 95% of the load rating chosen, the tension meter will probably not be adjustable to zero. If this is the case, one or more of the following changes must be made to reduce W COS (A) to less than 95% of the load rating:

1. Reduce the transducer wheel weight,
2. Increase angle (A),
3. Use the next higher load rating (this is the least desirable choice because it reduces transducer signal output).

WRAP 1

Tension Force F_T , above horizontal

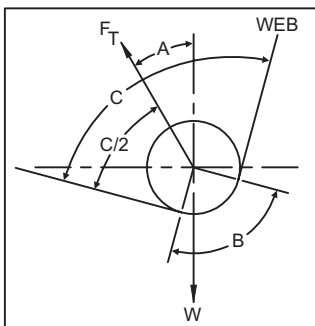

$$\text{NET FORCE} = 4T \sin\left(\frac{B}{2}\right) - W \cos(A)$$

WRAP 2

Tension Force F_T , below horizontal

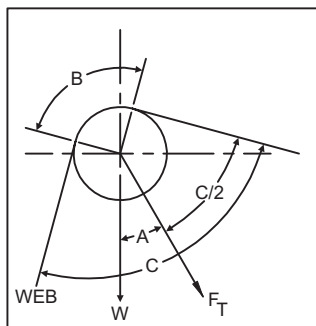

$$\text{NET FORCE} = 4T \sin\left(\frac{B}{2}\right) + W \cos(A)$$

WRAP 3

Tension Force F_T , is horizontal

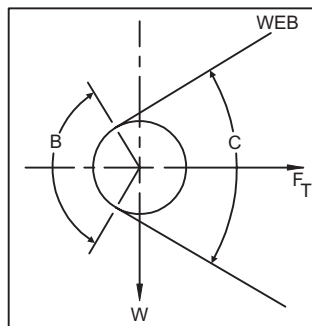

$$\text{NET FORCE} = 4T \sin\left(\frac{B}{2}\right)$$

TABLE 1

Angle (Degrees)	SINE	COSINE
0	.000	1.000
5	.087	.996
10	.174	.985
15	.259	.966
20	.342	.940
25	.423	.906
30	.500	.866
35	.574	.819
40	.643	.766
45	.707	.707
50	.766	.643
55	.819	.574
60	.866	.500
65	.906	.423
70	.940	.342
75	.966	.259
80	.985	.174
85	.996	.087
90	1.000	.000

W = idler roll weight, T = Maximum web tension, B = Wrap angle = $180^\circ - C^\circ$, A = Angle between Tension Force F_T and vertical

NOTE: Weight of standard filament wheel is 0.055 lbs. (25 grams) including bearings and fasteners.
Weight of standard ribbon wheel is 0.062 lbs. (28 grams) including bearings and fasteners.

DIMENSIONS inches (mm)

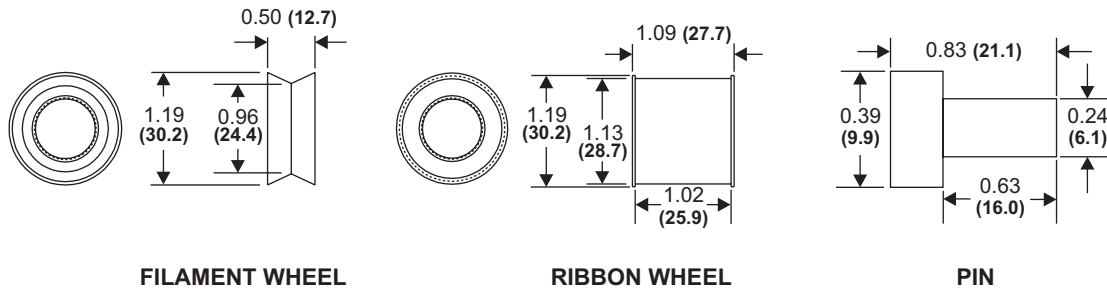
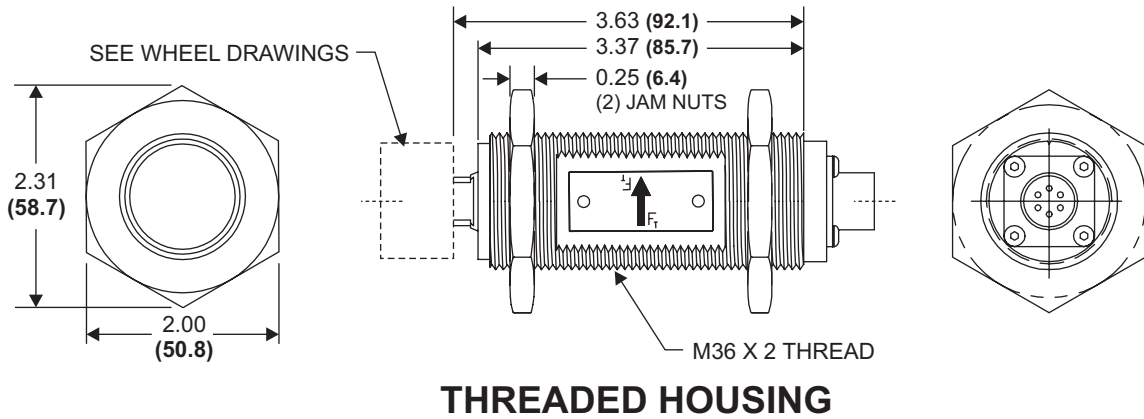
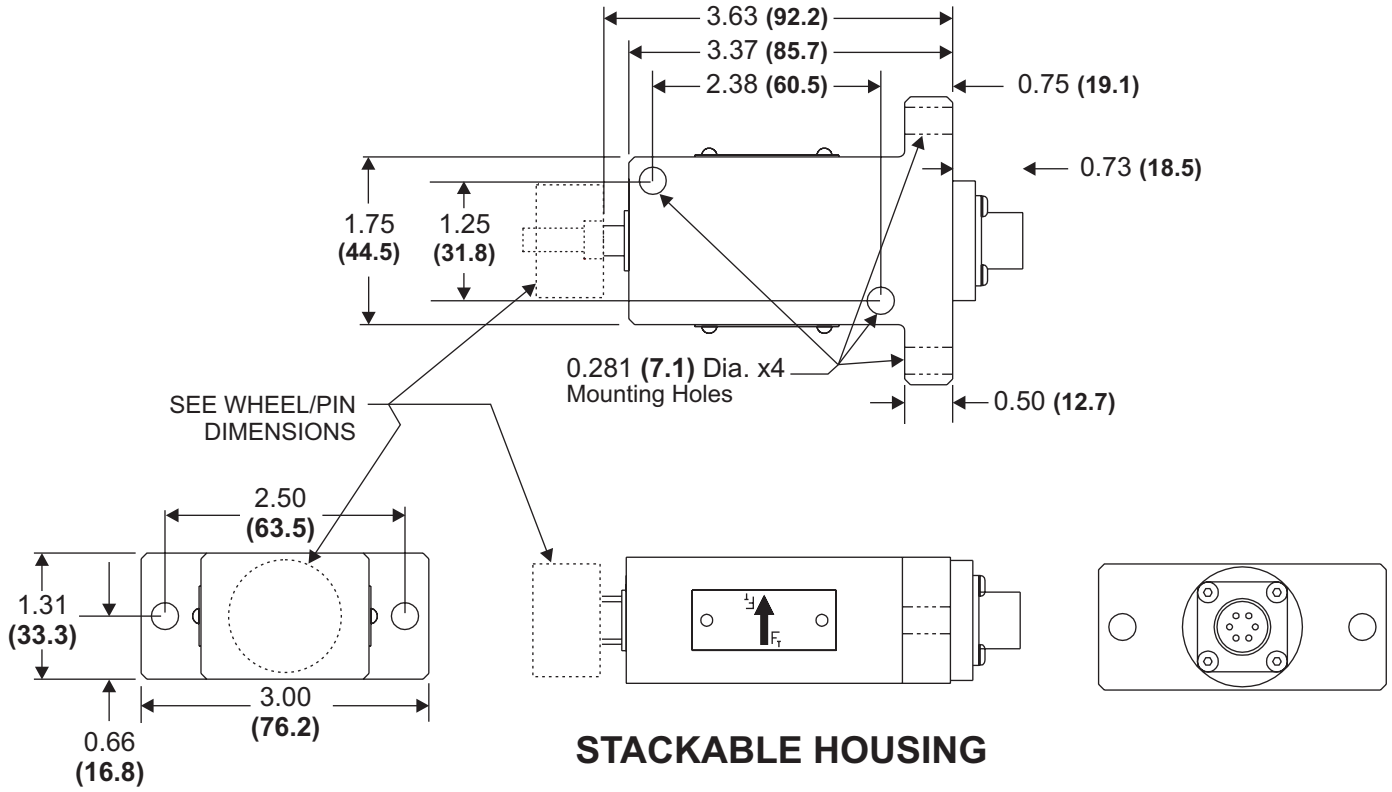

WHEEL/PIN DIMENSIONS