

# MODEL C TRANSDUCER

The Model C Tension Transducer is a strain-gauge tension-sensing device designed for versatility, accuracy, reliability, easy maintenance and quick trouble-free installation. It is the most technically advanced and robust shaft-mount tension transducer available. Used in a pair

## BENEFITS/FEATURES

- Measures actual web tension. Eliminates guess work and allows running correct tension consistently.
- Helps reduce or eliminate web breakage, stretching, registration and length problems by making it possible to control tension accurately.
- Sealed from dust and moisture; seals are recessed, blocking access from potential damage.
- Dual cantilever beam provides high strength and accuracy even at low tension.
- Temperature compensated for stable output.
- CE marked. Meets European low voltage (73/23/EEC) and EMC (89/336/EEC) directives.
- Stainless steel and aluminum construction for excellent corrosion resistance.
- All mounting styles can be rotated to any position for precise orientation.

## IN-FRAME MOUNTING STYLES

- **Piloted Flange (PFL)** - Mounting Style in which transducer has a piloted mounting flange that fits directly in place of industry standard RFC style 3.0" piloted flange bearings. Size 0 and 2 only.

## OPTIONS

- **Drill & Tap (D & T)** - Non-standard drill & tap for S or FL mounting styles.
- **Environmental Connector (EC)** - Seals with mating cable electrical connector to protect against contact oxidation; especially useful in corrosive environments.
- **Extended Range Output (XR)** - Extra sensitive to low tensions. XR produces twice the output signal for a given load rating. Electronics must also have extended range.
- **Full Bridge (FB)** - Four strain gauges instead of two to form a full Wheatstone Bridge connection. See Note 6.

## Available Mounting Styles

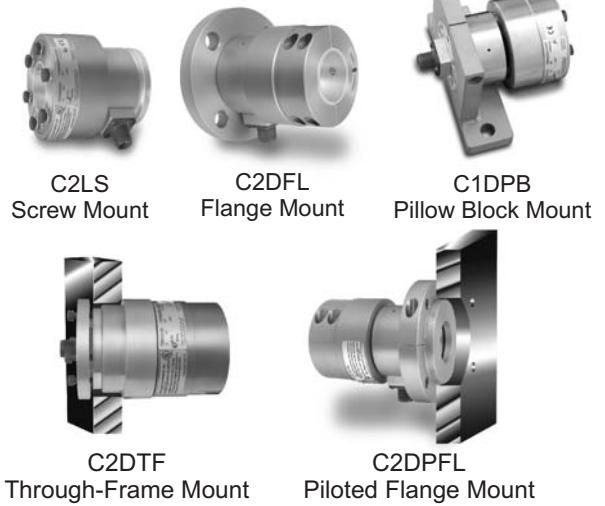

- Built-in compensation for changes in idler shaft length caused by temperature changes and deflection.
- Idler shaft can be removed from transducer without removing transducer from machine on the live (L) Split-Cap and dead (D) shaft version.

- **Through-Frame (TF)** - Mounting style in which a Model C transducer with rear connector fits into a recessed 72mm hole in machine frame. Saves space, and allows longer idler roll shaft. Size 2 only.

- **Labyrinth Seal (LS)** - A non-contact seal used for minimal drag for very low break-away torque. Used on Live shaft only. **Size 0,1:**Typ.0.3 oz-in. **Size 2:** 0.6 oz-in.
- **Metric Mounting Stud (MMS)** - Metric mounting screw for S type transducers.
- **No Cap (NCP)** - Live shaft transducer coupling with no clamp cap. Ensures a spin-centered installation of rotating shafts.
- **Vacuum Compensation (VAC)** - Special features for fast and complete air evacuation. Used for transducers installed in vacuum metalizers. Consult factory.

## PRODUCT CODE

You may order by description or by specifying the code by matching each labeled place with one of the choices below.

**EXAMPLE: C 1 D S - 10 - 1/2 - 12 - EC,XR**

SIZE TYPE MOUNTING STYLE LOAD RATING SHAFT BUSHING CONNECTOR POSITION OPTIONS

SIZE	TYPE	MOUNTING STYLE	LOAD RATING	SHAFT BUSHING				CONNECTOR POSITION <sup>4</sup>	OPTIONS
				SIZE 0,1 Dead	SIZE 0,1 Live	SIZE 2 Dead	SIZE 2 Live		
0 = Size 0 1 = Size 1 2 = Size 2	D = Dead L = Live	S = Screw / Bolt <sup>3</sup> PB = Pillow Block FL = Flange TF = Through-frame <sup>2</sup> PFL = Piloted Flange	10 lbs. <sup>1</sup> 25 lbs. 50 lbs. 100 lbs. 150 lbs. <sup>1</sup> 200 lbs. <sup>2</sup> 400 lbs. <sup>2</sup> 800 lbs. <sup>2</sup>	1/2 5/8 3/4 1 1 1/8 1 1/4 1 1/2 20mm 25mm 30mm	1/2 5/8 3/4 7/8 1 1 1/8 1 20mm 25mm 30mm	3/4 7/8 1 1 1/8 1 3/16 1 1/4 1 1/2 1 3/4 25mm 30mm 40mm	3/4 7/8 1 1 1/8 1 3/16 1 1/4 1 1/2 25mm 30mm 40mm	12 (12 :00) 1:30 3:00 4:30 6 (6:00) S, FL only 7:30 9:00 10:30 Rear (PB,TF <sup>8</sup> , FL <sup>9</sup> , PFL <sup>9</sup> only)	D & T = Drill and Tap EC = Environmental Connector XR = Extended Range <sup>5</sup> FB = Full Bridge <sup>6</sup> LS = Labyrinth Seal MMS = Metric Mounting Stud NCP = No Cap Live Shaft Coupling <sup>7</sup> VAC = Vacuum Compensation Z = Special (SPR)

1. Available on Size 0, 1 only.

2. Available on Size 2 only.

3. Standard mounting bolt for S and FL styles is in inches. Std Taps for the S style are: **Size 0** = 3/8 -16, M10, **Size 1** = 1/2 - 13, M12, and **Size 2** = 5/8 -11, M16

4. Connector position is figured relative to force direction for S and FL mounting styles and assumes force is at 6:00 o'clock. For PB mounting style, if the connector is not at rear, then the mount surface is considered the 6:00 o'clock position for force direction.

5. Requires that indicator/controller has XRE option.

6. Applies only if one transducer is used.

7. For Type L (live shaft) only.

8. Must use rear connector position for TF style.

9. Rear connector position available if hole in frame is through. Not available on Size 0.

# SPECIFICATIONS:

## ELECTRICAL

**Excitation:** 5 Vdc, regulated (10Vdc with XR)

**Output:** 250mVdc, nominal, at 5V excitation  
(500mV at 10V excitation with XR)

**Strain Gage Resistance:** 100 ohms, nominal

**Non-Repeatability:** ±1/4% Full Span (FS)

**Combined Non-Linearity and Hysteresis:** ±1/2% (FS)

**Temperature Range:** -10°F to 200°F (-23°C to 93°C)

**Temperature Coefficient:** 0.02% FS per °F, typical  
(0.036% FS per °C)

**Mating Electrical Connector:**

Amphenol MS3106A-10SL-3S

**Connector Pin Assignment:**

A = transducer output;

B = + 5V

C = -5V

## MECHANICAL

**Overload Capacity:** Size 0,1 = 1200 lbs. (5338 N),

Size 2 = 2500 lbs. (11,121 N),

**Deflection of Sensor Beam:** 0.005 in. max. (.127 mm)

**Material:** 6061, 7075-T6 Aluminum;

303, 304 Stainless Steel

**Connector Position (standard):**

Screw, Flange, and Piloted Flange mount = 6 o'clock  
(connector points in tension force direction)

Pillow Block and Through Frame = center rear

**Shaft Bushings (max.):**

Size 0,1 Dead = 1.5" (30mm) Live = 1" (20mm)

Size 2 Dead = 1.75" (40mm) Live = 1.5" (40mm)

**Basic Dynamic Load Rating of Bearings:**

Size 0,1: 1,990 LBF (8,840 N)

Size 2: 3,510 LBF (15,600 N)

## SELECTION OF LOAD RATING

The correct transducer load rating for your application is determined by maximum web tension, wrap angle, and roll weight. Choose the appropriate wrap configuration from the diagrams below. Then compute the Net Force using the formula below the diagram. (The direction of the tension force determines which diagram and formula to use).

The selected load rating, may be 20% less than the computed Net Force. The actual force on the transducer will read 125% of the load rating before hitting the stops. This is acceptable because the Net Force formula contains an oversizing factor of 2, which means that the actual force exerted on the transducer will not exceed its rating. Sometimes, a roll is so heavy that its weight uses up most of the operating range of the transducer. When this happens, it may not be possible to adjust the tension indicating meter to read zero when tension is zero

because the adjustment range of the electronic circuit has been exceeded. To find out if the roll is too heavy, compare the load rating with the effective weight of the roll as follows: The effective roll weight is the "WCOS(A)" term in the formula. If WCOS(A) is more than 95% of the load rating chosen, the tension meter will probably not be adjustable to zero. If this is the case, one or more of the following changes must be made to reduce WCOS(A) to less than 95% of the load rating:

1. Reduce the transducer roll weight
2. Increase angle (A)
3. Use the next higher load rating (This is the least desirable choice because it reduces transducer signal output).

**WRAP 1**

Tension Force  $F_T$ , **above** horizontal

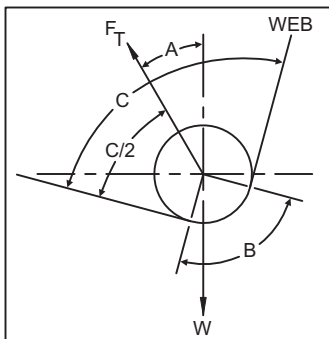

$$\text{NET FORCE} = \frac{4T \sin\left(\frac{B}{2}\right) - W \cos(A)}{2}$$

**WRAP 2**

Tension Force  $F_T$ , **below** horizontal

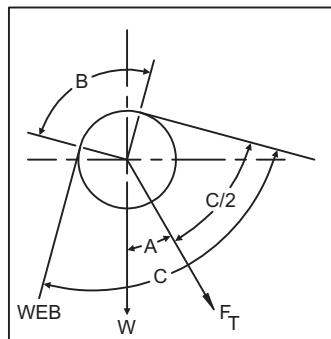

$$\text{NET FORCE} = \frac{4T \sin\left(\frac{B}{2}\right) + W \cos(A)}{2}$$

**WRAP 3**

Tension Force  $F_T$ , **is** horizontal

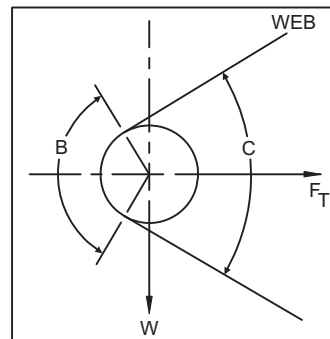

$$\text{NET FORCE} = \frac{4T \sin\left(\frac{B}{2}\right)}{2}$$

**TABLE 1**

Angle (Degrees)	SINE	COSINE
0	.000	1.000
5	.087	.996
10	.174	.985
15	.259	.966
20	.342	.940
25	.423	.906
30	.500	.866
35	.574	.819
40	.643	.766
45	.707	.707
50	.766	.643
55	.819	.574
60	.866	.500
65	.906	.423
70	.940	.342
75	.966	.259
80	.985	.174
85	.996	.087
90	1.000	.000

W = idler roll weight, T = Maximum web tension, B = Wrap angle =  $180^\circ - C^\circ$ , A = Angle between Tension Force  $F_T$  and vertical

**Note:** These sizing formulas contain an oversizing factor of 2X tension for tension surges.

# DIMENSIONS

SIZE		A (D) <sup>1</sup>	A (L) <sup>1</sup>	B	C	D	E	F (max)	G	H (max)	J	K (max)	L	M	N
0	in.	1.50	1.00	0.13	1.80	3/8 - 16	1.20	3.02	0.95	2.45	2.75	1.62	0.56	3.12	0.34
	mm	38.1	25	3.30	45.7	M10 x 1.5	30.5	76.7	24.1	62.2	69.9	41.4	14.2	79.2	8.6
1	in.	1.50	1.00	0.13	1.80	1/2 - 13	1.20	3.18	0.95	2.61	3.01	1.71	0.56	4.00	0.43
	mm	38.1	25	3.30	45.7	M12 x 1.75	30.5	80.8	24.1	66.3	76.5	43.4	14.2	101.6	10.9
2	in.	1.75	1.50	0.21	2.60	5/8 - 11	1.04	4.00	1.15	3.00	3.99	2.16	0.98	4.49	0.53
	mm	44.5	38	5.3	66	M16 x 2	26.4	101.6	29.2	76.2	101.3	54.9	24.9	114	13.5

**Notes:** 1: Bushings are available for smaller shaft diameters. D is for Dead shaft version, L is for Live Shaft version.

SIZE		P	Q	R	S (L)	S (D)	T	U	V	W	X	Y	Z	AA
0	in.	2.50	0.43	0.81	2.26	2.26	0.37	2.50	1.37	1.37	0.38	3.25	4.25	2.66
	mm	63.5	10.9	20.6	57.4	57.4	9.4	63.5	34.8	34.8	9.7	82.6	108	67.6
1	in.	3.25	0.53	0.72	2.26	2.26	0.53	2.50	1.41	1.63	0.38	4.00	5.38	2.66
	mm	82.6	13.5	18.3	57.4	57.4	13.5	63.5	35.8	41.4	9.7	101.6	136.7	67.6
2	in.	3.50	0.53	0.87	3.38	3.11	0.50	4.00	1.74	2.06	0.63	5.00	6.00	3.52
	mm	88.9	13.5	22.1	85.9	79	12.7	101.6	44.2	52.3	16	127	152	89.4

LIVE SHAFT "L" TAPERED COUPLING SHOWN

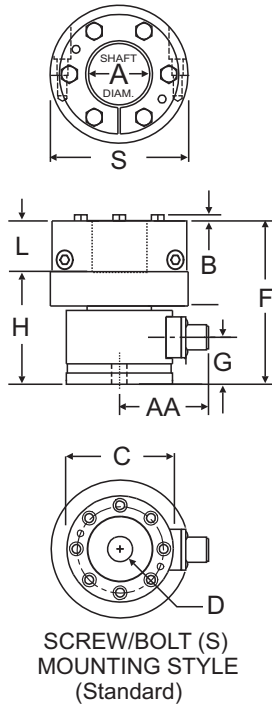

LIVE SHAFT "L" TAPERED COUPLING SHOWN

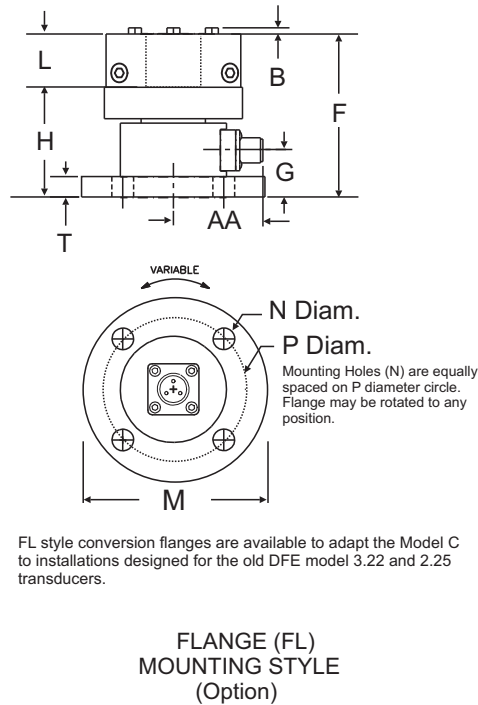

FL style conversion flanges are available to adapt the Model C to installations designed for the old DFE model 3.22 and 2.25 transducers.

DEAD SHAFT "D" SPLIT COUPLING SHOWN

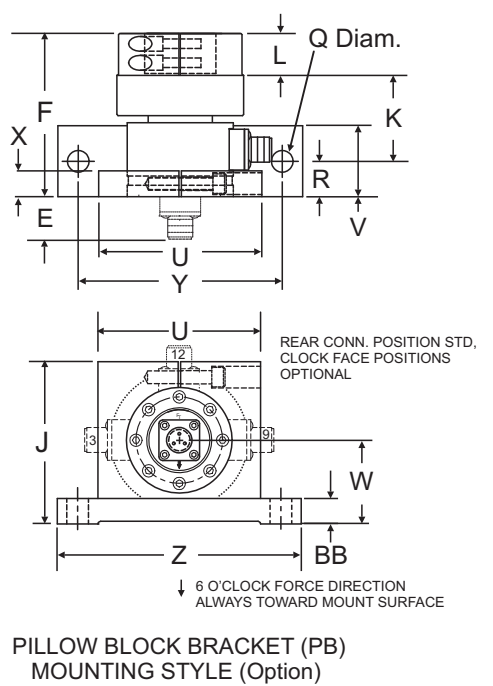

inches (mm)

DEAD SHAFT "D" SPLIT COUPLING SHOWN

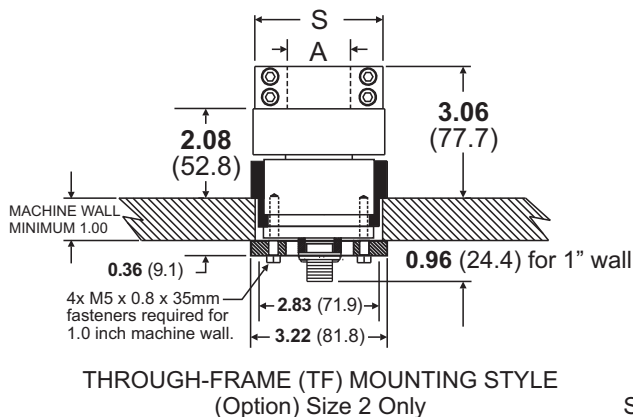

LIVE SHAFT "L" TAPERED COUPLING SHOWN

