

WEBHANDLER™

AUTOMATIC TENSION CONTROLLER



5 YEAR WARRANTY

WEBHANDLER™ Tension Controller

The **WebHandler™** is a low-cost automatic tension controller. It provides the superior performance of a high-end control system in a small, no frills package. This controller takes a tension signal from tension transducers and displays total web tension on an analog meter.

Whether used in unwind, intermediate or rewind zones, the **WebHandler™** automatically maintains a pre-selected level of web tension by sending a compensating output signal to a tensioning device such as a brake, clutch or a drive. Options are available as add-ons.

The **WebHandler™** is available in three versions with each featuring different outputs.

D - 0-10 Vdc compensated output for use with adjustable speed DC and AC drives. Used in all tension zones; unwind, rewind and intermediate.

V - 0-90 Vdc output. For use with all types of electrical brakes and clutches, including eddy current clutches. Also available with 24 and 45 Vdc output. Commonly used in the unwind or rewind zones.

P - 0-75 psi output for use with pneumatic clutches and brakes. Most commonly used in the unwind and rewind zones.

BENEFITS

- Reduces product waste, web breakage, registration inaccuracy and stretching problems.
- Installs quickly and simply.
- Operates over a wide range of tensions with automatic or manual control.
- Facilitates operation with push-button, front panel controls and analog tension meter.
- Features modular component design for easy upgrade.

FEATURES

- 115 Volts, 60 Hz Power Input
- Outputs including 0-75 psi pneumatic, 0-90 Vdc, 0-10Vdc, and a 4-20mA secondary output control signal.
- Auto/manual control modes
- Auto/Manual tension set pots.
- Emergency stop feature
- Tension Meter Damping - no vibration of needle
- Soft start capability - activated by low tension or external contact
- Status Lights - show activity of functions
- Analog tension meter
- Tension Limit Switch - Relay activates at a pre-set adjustable trip point. Can be used as a web break detector.

OPTIONS

- **230 Volts (230)**. 60Hz Power Input.
- **24 Vdc and 45 Vdc** Outputs. For "V" version only.
- **Attached Power Cord (APC)**. A heavy duty 3 connector power cord wired to the WebHandler™ by DFE.
- **Digital Meter (DM)**. Digital meter in place of the analog meter.
- **Driver Card (DRVR)**. Driver circuit card for non-DFE servo valve. For "P" version only.
- **Dual Valve Servo (DVS)**. Servo valve having two solenoid valves and output pressure feedback.
- **Air Filter (FILT)**. Air filter installed with servo valve.
- **Extended Range (XRE)**. Allows twice the excitation of the transducers being used. Transducers must also have extended range.
- **0-10Vdc Isolated Output (I10)**. A 0-10 Volt output which is not connected to circuit common, or to earth ground. To interface with DC drives or PLC's.
- **Non-Standard Meter Scale (NMS)**. Custom scales for those not listed as standard.
- **Reverse Output (RO)**. Output goes up instead of down when tension exceeds setpoint.
- **Remote Operator Panel (ROP)**. Front panel with operator devices attached to controller with 6' cable.
- **Remote Tension Amplifier (RTA)**. Tension amplifier in controller is not used and is replaced by a remotely located amplifier.
- **Line Speed Follow (SFD)** with DC Tach. Output is determined by a DC tach speed signal and trimmed by the transducer signal. Recommended in intermediate zones.
- **Taper Tension by Diameter Follower (TTF)**. Tension tapers with diameter increase as sensed by a follower roll or sonic rangefinder.

SPECIFICATIONS

Power Input:

P: 115/230 Volts 60/50Hz Single Phase @ 1 amp
 V: 115/230 Volts 60/50Hz Single Phase @ 5 amps
 D: 115/230 Volts 60/50Hz Single Phase @ 1 amp

Output Control Range:

P: 0.5 to 75 psi (0.03 to 5.17 bar)
 V: 90, 45 or 24Vdc, all @ 5 amps w/115Vac in **OR**
 90 or 45Vdc, all @ 5 Amps w/230Vac in
 D: 0 to ±10Vdc, Compensated (Optional isolated)
 P,V,D = 4-20mA Control Output Signal **AND**
 Choice of 0-10Vac or 0-1mA tension indication
 To external device.

Enclosure:

Steel, powder resin painted, NEMA 1

Weight:

9 lbs. (4.1 kg)

Transducer Signal:

500 mVdc per pair at rated load (1000mV w/XR option)

Mating Transducer Cable Connectors:

Amphenol MS3106A-10SL-3S

Zero Range:

95% of transducer rating, minimum

Calibration Range:

25:1 Max

Temperature Range

32°F to 104°F (0°C to 40°C)

System Accuracy:

Within 1% to 3% typical

Tension Meter:

Analog, 2%, 1ma, 48 ohm

Output Range

0%-100% Max.

Manual Output Range

0% to 100% of rated output

Standard Tension Meter Scales

0 - 1, 5, 10, 25, 50, 100, 150, 250, 500, 1000

Taper Tension Range (option)

0%-100% adjustable

Taper Tension by Rider Roll/Diameter Sensor

0-10Vdc input

Pneumatics:

1. Remote Pneumatic enclosure (RPE)

Input: 125 psi

Output: 0.5 to 75 psi (0.03 to 5.17 bar)

Servo Valve Drive Signal: 0-100mA

Air Connections: In = 1/4 NPT, Out = 1/8 NPT

Weight: 2.84 lbs. (1.28 kg)

2. Dual Valve Servo Enclosure (DVS)

Power Input: 24Vac/dc @ 200mA

Input: 100 psi (6.9 bar) max.

Output: 0 to 75 psi (0 to 5.17 bar)

Servo Valves Drive Signal: 1-5 Vdc

Air Connections: In = 1/4 NPT, Out = 1/4 NPT

Weight: 2.3 lbs. (1.04 kg)

ORDERING INFORMATION

You may order by description, or by matching the labeled digits with your choices.

Example: WH2P-R-100-DM,XRE,

WH2X - **X** - **XXX** - **OPTIONS** (Separated by commas)

OUTPUT	ZONE	METER SCALE	OPTIONS
P = Pneumatic V = Electric D = Drive	U = Unwind R = Rewind I = Intermediate	1 = 0-1 5 = 0-5 10 = 0-10 25 = 0-25 50 = 0-50 100 = 0-100 150 = 0-150 250 = 0-250 500 = 0-500 1000 = 0-1000	230 = 230 Volt Power Input 24 = 24 Vdc Output ³ 45 = 45 Vdc Output APC = Attached Power Cord DM = Digital Meter DRVR = Driver Card for non-DFE Servo Valve ¹ DVS = Dual Valve Servo ¹ FILT = Air Filter ¹ 110 = Isolated 10V Output NMS = Non-Standard Meter Scale RO = Reverse Output ROP = Remote Operator Panel RTA = Remote Tension Amplifier RTS = Remote Tension Switch ¹ SFD = Line Speed Follow TTF = Taper Tension by Diameter Follower XRE = Extended Range ²

Notes: 1. WH2 "P" version only. 2. Transducers must have XR option 3. 115 Vac only.

DIMENSIONS

inches (mm)

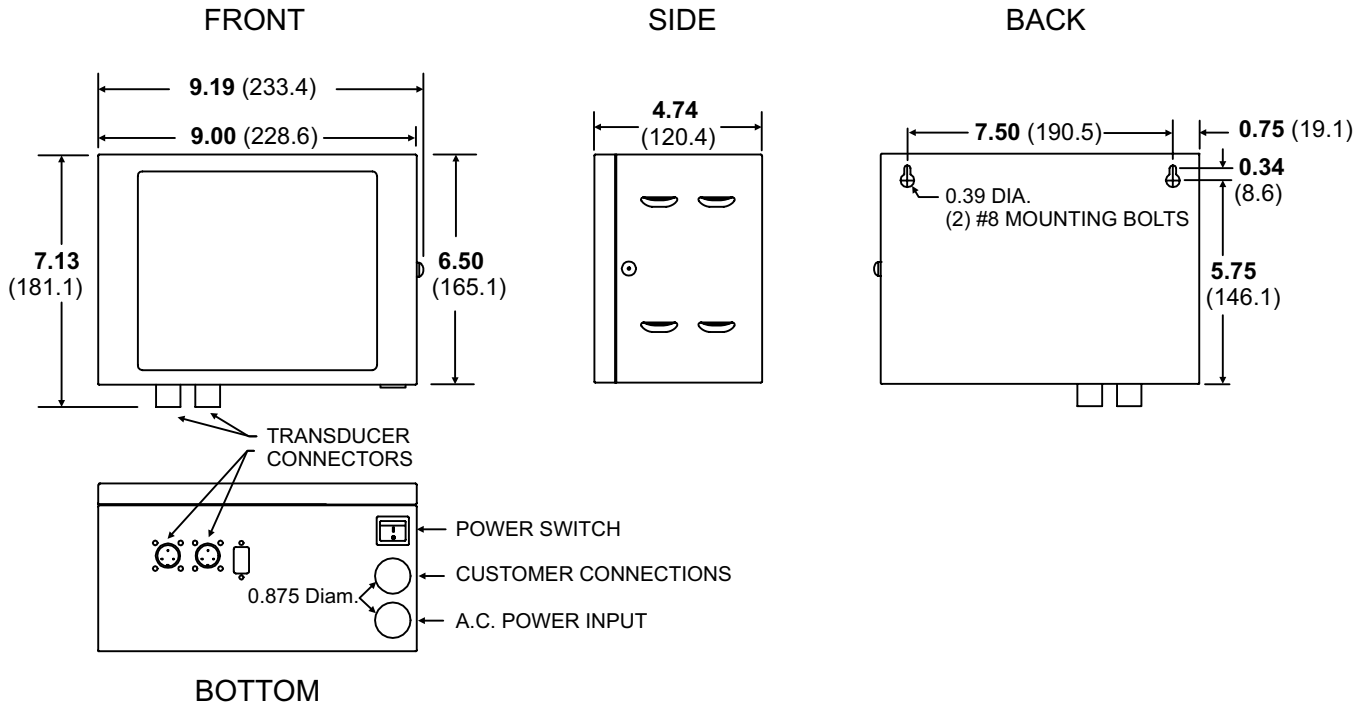

REMOTE PANEL DIMENSIONS

inches (mm)

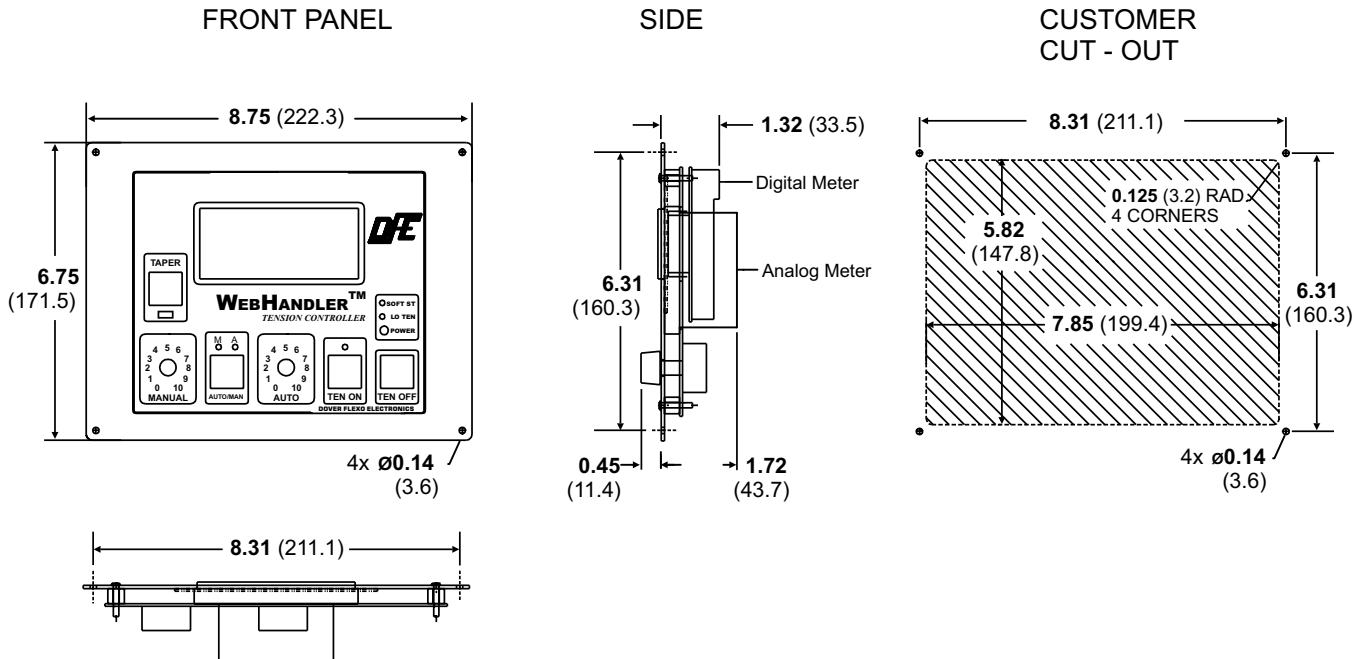

DFE THE TENSION CONTROL SPECIALISTS
DOVER FLEXO ELECTRONICS, INC.
 217 PICKERING ROAD, ROCHESTER, NH 03867 USA • 603-332-6150 • FAX 603-332-3758
 E-Mail: info@dfec.com • Internet: www.dfec.com • ISO 9001 Certified