

NWI NARROW WEB Tension Transducer

The NWI Transducer is a specialized bearing-mounted idler roll with integrated dual tension sensors for measuring tension in a moving narrow web of paper, film, foil or other material. Constructed of stainless steel and aluminum for excellent corrosion resistance, the NWI transducer can be used as the sensing mechanism in a web tension control or display system in a continuous label, tag, or tape process. It mounts on a single-sided machine frame in the path with the cantilevered idler rolls.

Precision-balanced sensing elements fixed internally at each end of the idler roll deliver a highly accurate tension signal. The NWI measures total web tension regardless of web position on the roll, and regardless of which edge of the web is tighter.

A popular option of the NWI transducer is the built-in

LED tension display at the end of the roll. The base of the NWI roll bolts onto the cantilevered frame of a press or machine at a desired point in the web path and, during operation, reads out running tension on the LED display. For a machine operator, who must make control adjustments when web tension runs outside acceptable limits, the direct on-roll tension display is convenient and easy-to-read. This indicator option includes its own 115/230 Vac power supply. It also includes a 0 to 10 VDC output with terminal block for wiring the output to a drive, PLC or other device. An optional power supply enclosure is available.

The Narrow Web transducer is covered by DFE's Tension-FreeSM 5-YEAR PRODUCT WARRANTY.

BENEFITS

- Measures actual web tension.
- Promotes improved product quality and reduces waste.
- Does not affect the web. No steering effect, web breakage or length change.
- Idler roll is included. Nothing else to buy.
- High accuracy.
- Easy to install.

FEATURES

- Wide operating tension range.
- Four standard load ratings.
- Two mounting styles: four bolt flange or single bolt.
- Seven roll widths up to 20 inches. Special widths available.
- Used with any standard Dover Tension Controller or Indicator, or with built-in Indicator Display option.
- Requires little machinery space.

OPTIONS

- **Attached Power Cord (APC).** A heavy duty 3 conductor power cord wired to the device by DFE.
- **Environmental Connector (EC).** Keeps liquid from entering transducer through the connector.
- **Enclosure (ENCL).** Optional enclosure for IND power supply.
- **Extended Range (XR).** Allows twice the excitation of the transducer being used. Electronics must also have extended range option.
- **Hard Coat (HC).** Black dye anodized hard coat.
- **Indicator Option (IND).** Tension display in end of roll with separate power supply and 15 foot cable. A 20 ft. cable (721-1611), or special length cable (721-0984) may also be ordered.
- **Metric Mount Stud (MMS).** Metric mounting screw for S type transducers.
- **Non-Lubricated Bearings (NLB).** No lubrication for bearings. For lowest drag torque. Voids warranty.
- **Oiled Bearings (OB).** Uses oil instead of grease for lubrication. For low drag torque. Voids warranty.
- **Short Connector Housing (SCH).** Allows inner roll edge to be closer to machine frame.
- **Split Flange (SFL).** Split mounting flange for transducers.
- **Steel Roll (SR).** Roll is made of steel.
- **Stainless Steel Roll (SSR).** Roll is made of stainless steel.

ORDERING INFORMATION

You may order by description, or by matching the labeled digits with your choices.

Example: NWIS-10-12-6-XR,OB

NWIX - X - XXX - XXX - OPTIONS (Separated by commas)

MOUNTING STYLE	ROLL WIDTH inch (mm)	LOAD RATING lbs. (N)	CONNECTOR POSITION	OPTIONS
S = Screw / Bolt FL = Flange	7 (178) 10 (254) 12 (305) 14 (356) 16 (406) 18 (457) 20 (508) Specify ^{1, 5}	12 (55) 25 (110) 50 (225) 100 (450)	6 (6 :00) Std. 1:30 3:00 4:30 7:30 9 (9:00) 10:30 12 (12:00)	APC = Attached Power Cord ⁶ EC = Environmental Connector ENCL = Enclosure for Power Supply ⁴ HC = Hard Coat, Anodized black dye IND = Tension Indicator Display ³ MMS = Metric Mounting Stud NLB = Non-Lubricated Bearings OB = Oiled Bearings SCH = Short Connector Housing SFL = Split Flange SR = Steel Roll SSR = Stainless Steel Roll XR = Extended Range ² Z = Special (SPR)



Narrow Web Transducer with optional Indicator Display & Hard Coat

1. Extra cost for non-standard widths.
2. XR option requires electronics to have XRE option.
3. IND option consists of tension display in end of roll and separate power supply card and 15' cable.
4. Enclosure for IND power supply card.
5. Roll widths over 20 inches have extended connector housing.
6. Can be used only when IND and ENCL options are used together.

SPECIFICATIONS

ELECTRICAL

Excitation: 5 Vdc (10 Vdc with XR option)
Output: 500mVdc, nominal (1 Vdc with XR option)
Gage Resistance: Half bridge at each end of idler roll. 100 Ohms, nominal, each gage.
Power Input (IND Option): 115V/230V 50/60 Hz
Non-Repeatability: ± 1/4% full span, typical
Combined Non-Linearity and Hysteresis: ± 1/2% FS
Temperature Range:
 Standard NW: -10°F to 200°F (-23°C to 93°C)
 IND Option: 40° to 104°F (4°C to 40°C)
Temperature Coefficient: 0.02% per ° F, typical (0.036% per °C)
Mating Electrical Connector:
 Amphenol MS3106A-14S-6S
Electrical Connector Position:
 6 o'clock, same as load direction is standard. Also 1:30, 3:00, 4:30, 7:30, 9:00, 10:30, 12:00
Output Ratio End-to-End: 99%

MECHANICAL

Deflection of Sensor Beam: 0.008 inch max (0.20 mm)
Load Ratings: 12, 25, 50, 100 lbs. (55, 110, 225, 450 N)
Overload Rating: 400 lbs. (1780 N) minimum, in load direction, without damage
Standard Roll Widths: 7, 10, 12, 14, 16, 18, 20 inches (178, 254, 305, 356, 406, 457, 508 mm)
No-Load Perpendicularity: 0.005 inches per foot of shaft length.
Display (IND Option): Red LED, 2 ½ digits, 0.56" character height
Orientation: The transducer may be installed in any position
Roll: Material = 6061 Aluminum, TIR = 0.001 inch for 3.5" diameter roll, Balance = quality grade G2.5 per ISO 1940/1-1986/E & ANSI S2.19-1989, Finish = 32 microinch
Basic Dynamic Load Rating of Bearings: 6910 lbs (30700N)
Shaft and Shaft Housing: Steel and Stainless Steel
Break-away Torque, greased bearing: 0.87 oz-in (62.6 gram-cm). Optional Oiled bearing: 0.38 oz-in (27.36 gram-cm)

SELECTION OF LOAD RATING

The Model "NWI" Transducer is available with four standard load ratings. The correct transducer load rating for your application is determined by maximum web tension, wrap angle, and roll weight. Choose the appropriate wrap configuration from the diagrams below. Then compute the Net Force using the formula below the diagram. (The direction of the tension force determines which diagram and formula to use). In some cases, the load rating may be less than the computed Net Force. This is acceptable because the Net Force formula contains an oversizing factor of 2, which means that the actual force exerted on the transducer will not exceed its rating.

The following applies only to steel rolls and rolls in excess of 14 inches (356 mm) in width:

Sometimes a roll is so heavy that its weight uses up most of the operating range of the transducer. When this happens,

it may not be possible to adjust the tension indicating meter to read zero when tension is zero because the adjustment range of the electronic circuit has been exceeded. To find out if the roll is too heavy, compare the load rating with the effective weight of the roll as follows: The effective roll weight is the "W COS(A)" term in the formula. If W COS(A) is more than 95% of the load rating chosen, the tension meter will probably not be adjustable to zero. If this is the case, one or more of the following changes must be made to reduce W COS(A) to less than 95% of the load rating:

1. Reduce the transducer roll weight
2. Increase angle (A)
3. Use the next higher load rating (this is the least desirable choice because it reduces transducer signal output).

Note 1: Roll weight equals weight of roll shell plus weight of bearing assemblies.

Roll Shell Weights

7 in. (178mm) is 1.3 lbs (0.6kg)
 10 in. (254mm) is 2.2 lbs (1 kg)
 12 in. (305mm) is 2.6 lbs (1.2 kg)
 14 in. (356mm) is 3.1 lbs (1.4 kg)
 16 in. (406mm) is 3.5 lbs (1.6 kg)
 18 in. (457mm) is 4 lbs (1.8 kg)
 20 in. (508mm) is 4.4 lbs (2 kg)

Weight of bearing assemblies
 is 1.7 lbs. (0.77 kg) total

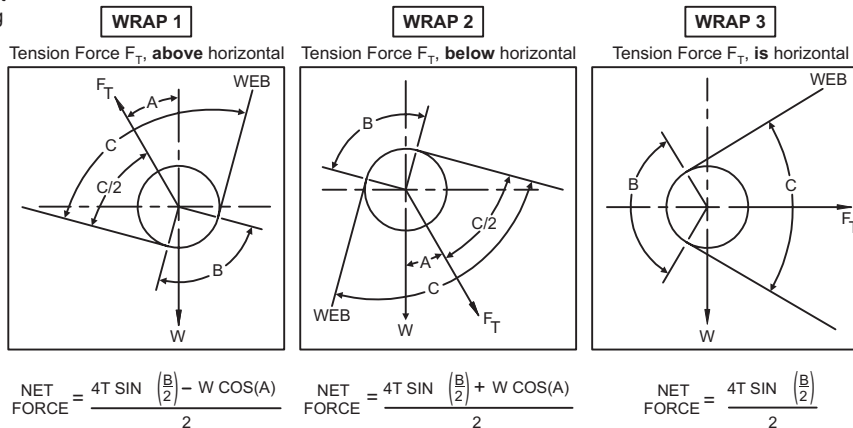

W = idler roll weight (See Note 1), T = Maximum web tension, B = Wrap angle = 180° - C°, A = Angle between Tension Force F_T and vertical

Angle (Degrees)	SINE	COSINE
0	.000	1.000
5	.087	.996
10	.174	.985
15	.259	.966
20	.342	.940
25	.423	.906
30	.500	.866
35	.574	.819
40	.643	.766
45	.707	.707
50	.766	.643
55	.819	.574
60	.866	.500
65	.906	.423
70	.940	.342
75	.966	.259
80	.985	.174
85	.996	.087
90	1.000	.000

DIMENSIONS

inches (mm)

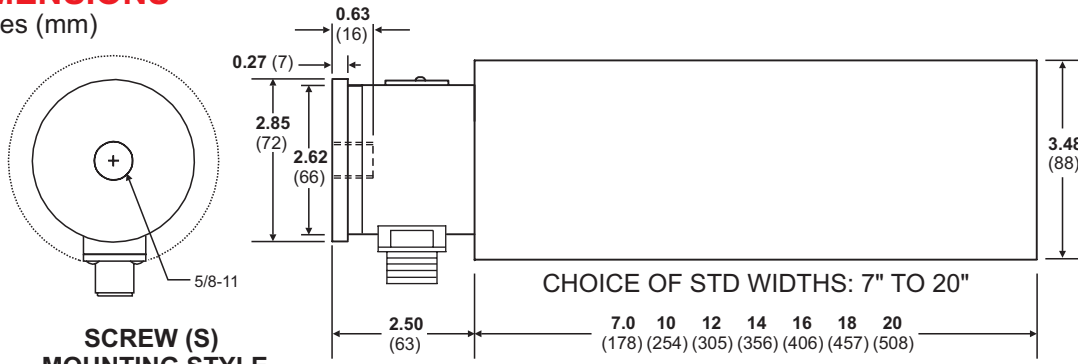

SCREW (S) MOUNTING STYLE

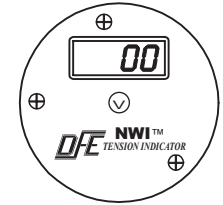

INDICATOR (IND) OPTION DISPLAY

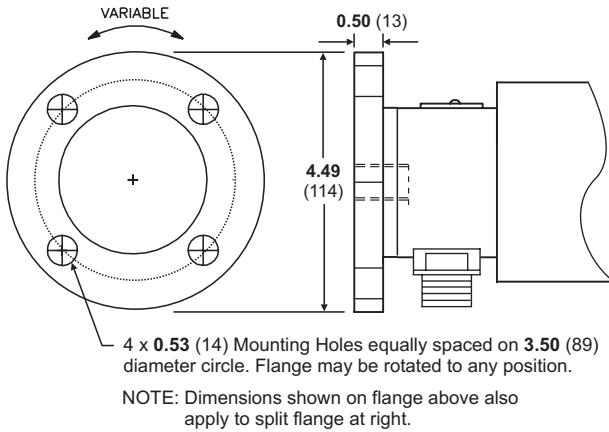

FLANGE (FL) MOUNTING STYLE

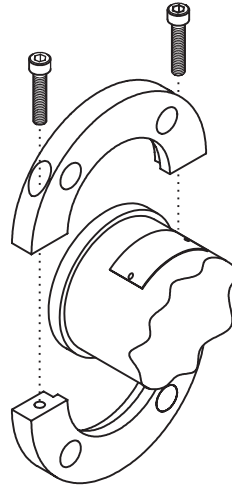

SPLIT FLANGE (SFL) MOUNTING STYLE

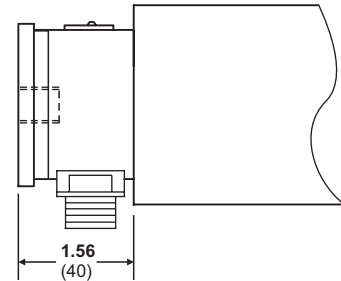

SHORT CONNECTOR (SCH) HOUSING

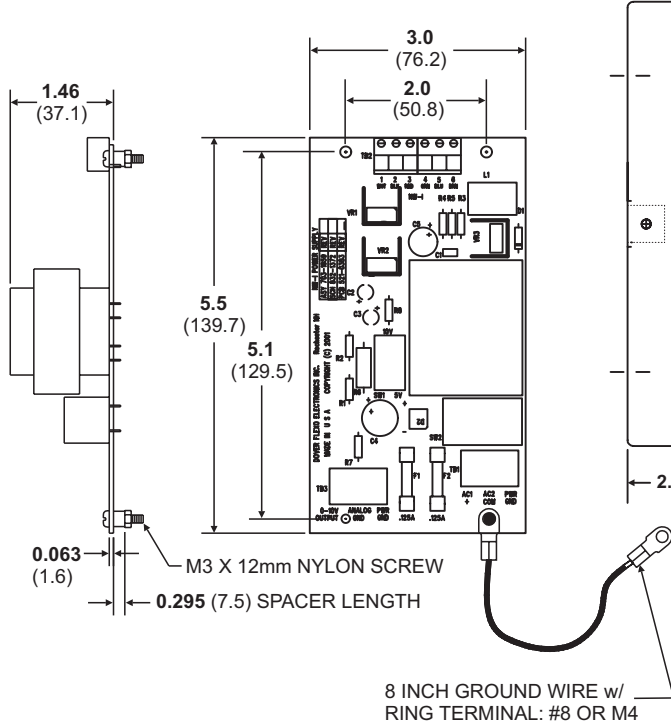

POWER SUPPLY AND TRANSDUCER INTERFACE CARD FOR INDICATOR DISPLAY OPTION (IND)

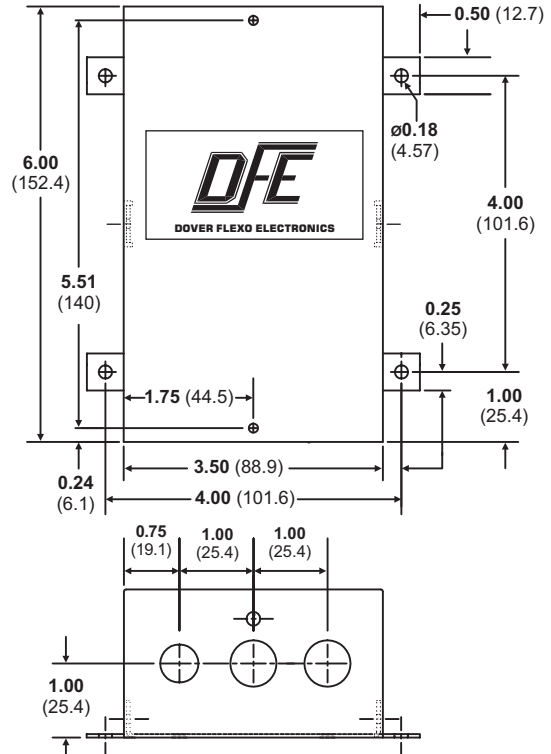

OPTIONAL ENCLOSURE (ENCL) FOR POWER SUPPLY CARD

DFE THE TENSION CONTROL SPECIALISTS
DOVER FLEXO ELECTRONICS, INC.
 217 PICKERING ROAD, ROCHESTER, NH 03867 USA • 603-332-6150 • FAX 603-332-3758
 E-Mail: info@dfc.com • Internet: www.dfc.com • ISO 9001 Certified