

INSTRUCTION MANUAL
Digital Torque Controller

EASYWEB™

DOC 801-2447

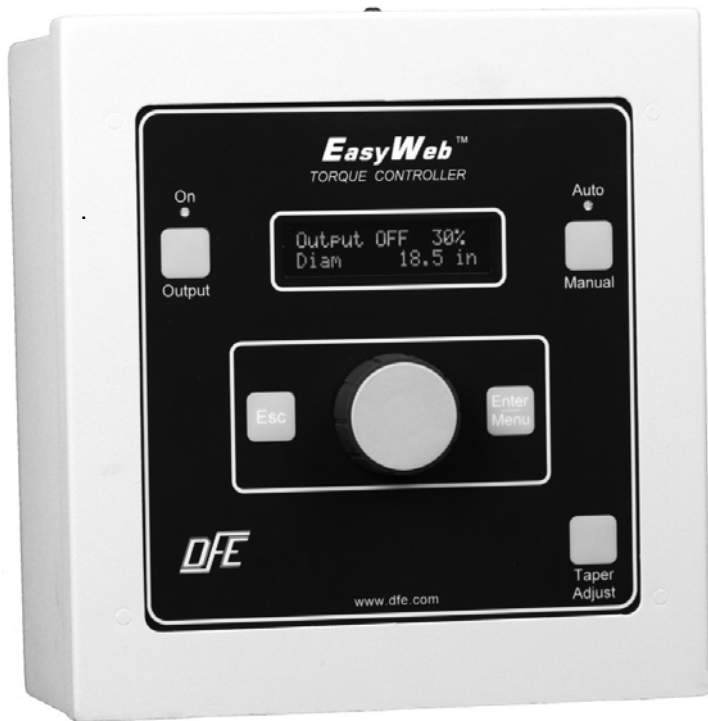

5 YEAR WARRANTY

DFE DOVER FLEXO ELECTRONICS, INC.
307 Pickering Road

Rochester, NH 03867-4630 U.S.A.

For assistance, please call:

TECHNICAL SERVICE - Installations, Start-Up, Troubleshooting, Repairs, Field Service, Returns. **techsupport@dfc.com**

CUSTOMER SERVICE - Replacement Parts, Individual Products, Questions about Orders, Manuals. **customerservice@dfc.com**

SALES - Product Information, Systems Application Questions, and placing orders for standard products and special systems.
sales@dfc.com

Telephone: (603) 332-6150 Fax: (603) 332-3758

E-mail: info@dfc.com Internet: www.dfc.com

READ THIS!

Your EasyWeb™ Controller has been properly configured at our factory. To install it and start it up, it should only be necessary to use these sections of this manual:

Section 2 - Installation

Section 3 - Calibration and Set-Up

The other sections are for reference and for instruction if you wish to change the configuration at some later time.

EASYWEB™ ORDER CODE

Your unit's order code description matches the labeled digits with your choices.

Example: EWP-U-E-AC-45-LDC

EWX - X - X - XX - OPTIONS (Separated by commas)

OUTPUT	ZONE	PACKAGING	POWER	OPTIONS
P = Pneumatic V = Electric D = Drive	U = Unwind R = Rewind	E = Enclosure O = Open (panel mount)	AC = 100-240V, 50/60Hz 24 = 24 VDC	230 = 230 Volt Power Input (1) 24 = 24 Vdc Output (2) 420 = 4-20mA Output (4) 45 = 45 Vdc Output (2) DRC = Din Rail Clip (5) LDC = Line Speed by DC Tach MPF = Metric Pneumatic Fittings (3) RDC = Roll Speed by DC Tach Z = SPR

Notes: 1. V version only, 230 refers to power input of V module. 2. V version only, 24 and 45 refer to the output voltage of V module.
 3. P version only. Used for all air connections. 4. 420 replaces the standard 0-10Vdc output. 5. VOUT enclosure only.

TABLE OF CONTENTS

SECTION ONE	PRODUCT DESCRIPTION	PAGE
1.1	General Description	1
1.2	Tension Zones	1
1.3	Version of Controller	2
1.4	Specifications	3
1.5	Environmental Conditions	4
1.6	Standard Features	4
1.7	Options	5
1.8	Accessories	5
SECTION TWO	INSTALLATION	
2.1	Standard Dimensions	6
	Dimensions of Remote Panel Configuration	6
	Dimensions of Remote Servo Valve Enclosure	7
	Dimensions of High Voltage Output Enclosure	7
2.2	Selection of Mounting Location	8
2.3	Safety and EMC Requirements	8
2.4	Installation Instructions	10
2.5	Control Output Selection	11
2.6	Emergency Stop Configuration	11
2.7	Customer +10/15V Output Selection	12
2.8	Power Electrical Connections	12
2.9	Standard Electrical Connections	13
2.10	Option Card Mounting Locations	15
2.11	DC Tachometer Option Card Electrical Connections	15
2.12	External Output Module Cable Connections	16
2.13	High Voltage Output Module Electrical Connections	16
SECTION THREE	CALIBRATION	
3.1	Diameter Input Calibration	17
3.2	Line/Roll Speed Input Calibration	18
3.3	DC Tachometer Calibration	19
3.4	Pulse Tachometer Calibration	20
3.5	Signal Filtering	21
SECTION FOUR	SETUP	
4.1	General Setup	22
4.2	Soft Start Setup	23
4.3	Anti-Tamper Security Lockout	24
SECTION FIVE	OPERATING INSTRUCTIONS	
5.1	Basic Operation	25
5.2	Operating Modes and User Interface	26
5.3	Operator Menu	26
5.4	Using Taper Tension	27
SECTION SIX	CARE AND MAINTENANCE	28
SECTION SEVEN	TROUBLESHOOTING GUIDE	
7.1	Diagnostic Menu	29
SECTION EIGHT	REPLACEMENT PARTS LIST	30

APPENDICES

A	Locations of Jumpers and Adjustments	31
B	Menu Hierarchy	32
C	Electrical Connections	33
D	Environmental Terms	34
	Terms and Conditions	35
	Index	37

LIST OF ILLUSTRATIONS

1.	Front View of EasyWeb	1
2.	Examples of Tension Zones	2
3.	Enclosure Version Dimension and Views	6
4.	Panel Version Dimensions	6
5.	Pneumatics Enclosure Dimensions	7
6.	High Voltage Output Enclosure Dimensions	7
7.	Enclosure Version Service Access	10
8.	Control Output Jumpers	11
9.	E-Stop Setup Jumpers	12
10.	24VDC and AC Power Electrical Connections	13
11.	Standard and 10 Volt Control Board Electrical Connections	13
12.	Diameter Alarm Connections	14
13.	Option Card Mounting Locations	15
14.	DC Tachometer Electrical Connections	15
15.	External Output Module Cable Connections	16
16.	High Voltage Output Module Electrical Connections	16
17.	DC Tachometer Card Electrical Connections & Adjustments	18
18.	Controller Output vs Diameter	25
19.	EasyWeb User Interface	26
20.	Locations of Jumpers and Adjustments	31
21.	Menu Hierarchy	32
22.	Electrical Connections	33

1.1 GENERAL DESCRIPTION

The EasyWeb™ is an open loop diameter compensated torque controller designed to provide constant web tension in rewind and unwind applications. Constant web tension is maintained by varying the torque of a brake, clutch, or drive with the change in roll diameter. Roll diameter is calculated by dividing line and roll speed signals or through direct diameter measurement using a roll follower or ultrasonic range finder. This allows for a reliable, easy-to-use system that requires minimum attention by the operator.

The EasyWeb™ can be powered by 24VDC or with a built-in 100-240VAC power supply and is available in Open (panel) and Enclosure mount configurations. The controller is offered in multiple output versions. The easy-to-use interface features a bright 2-line OLED display, spinning knob, and a combination of pushbuttons to easily navigate through the intuitive user menu.

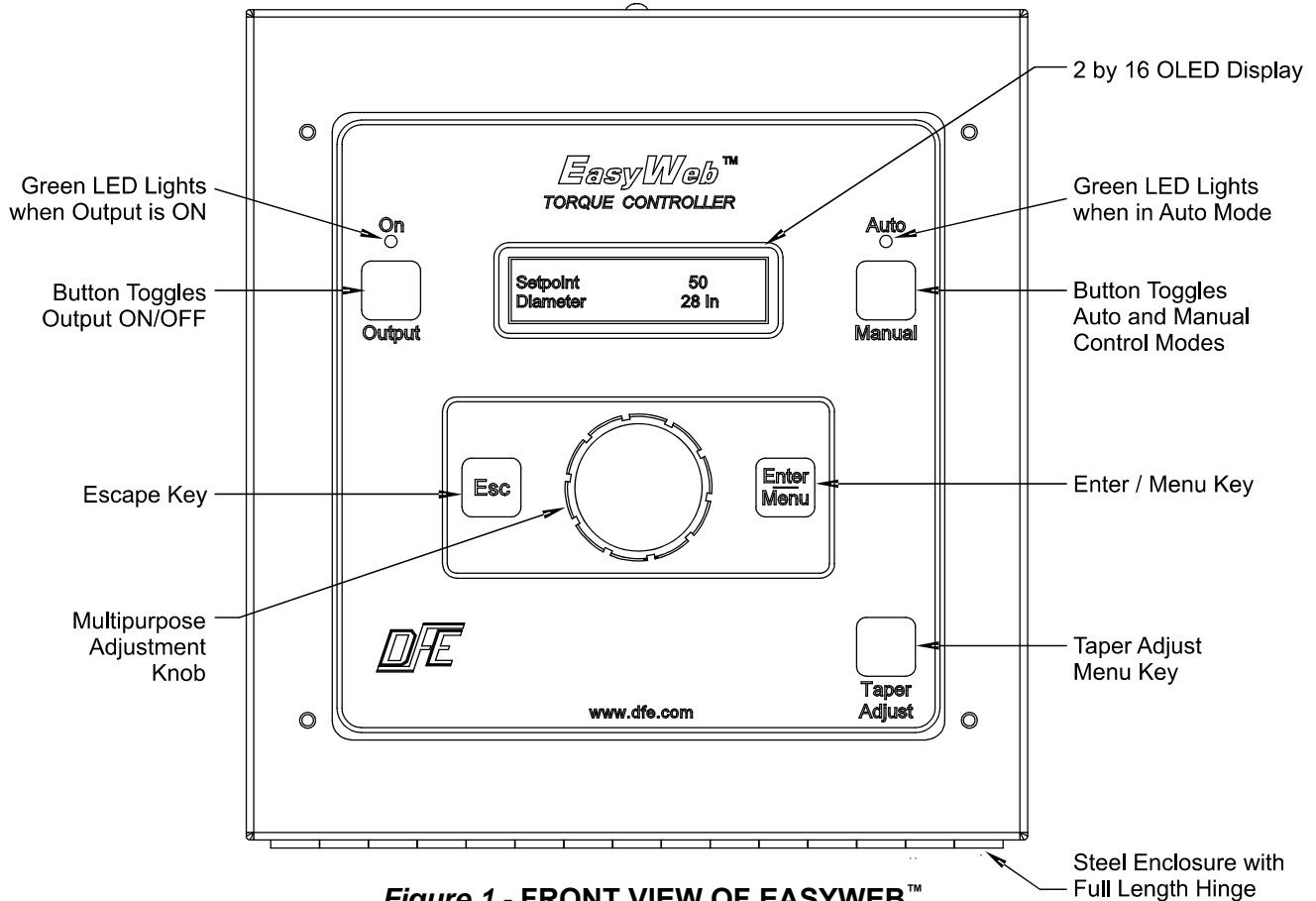

Figure 1 - FRONT VIEW OF EASYWEB™

1.2 TENSION ZONES

Tension zones are created by driven or braked nip rolls, drag bars, unwind or rewind shafts, or anything else that can increase or decrease web tension. One of these elements is at each end of every tension zone.

Many machines that process a continuous web have more than one tension zone. The EasyWeb controller is designed to be used in unwind and rewind zones only. For intermediate zones a transducer based controller is generally required. See Figure 2 for examples of tension zones.

1.2 TENSION ZONES *continued...*

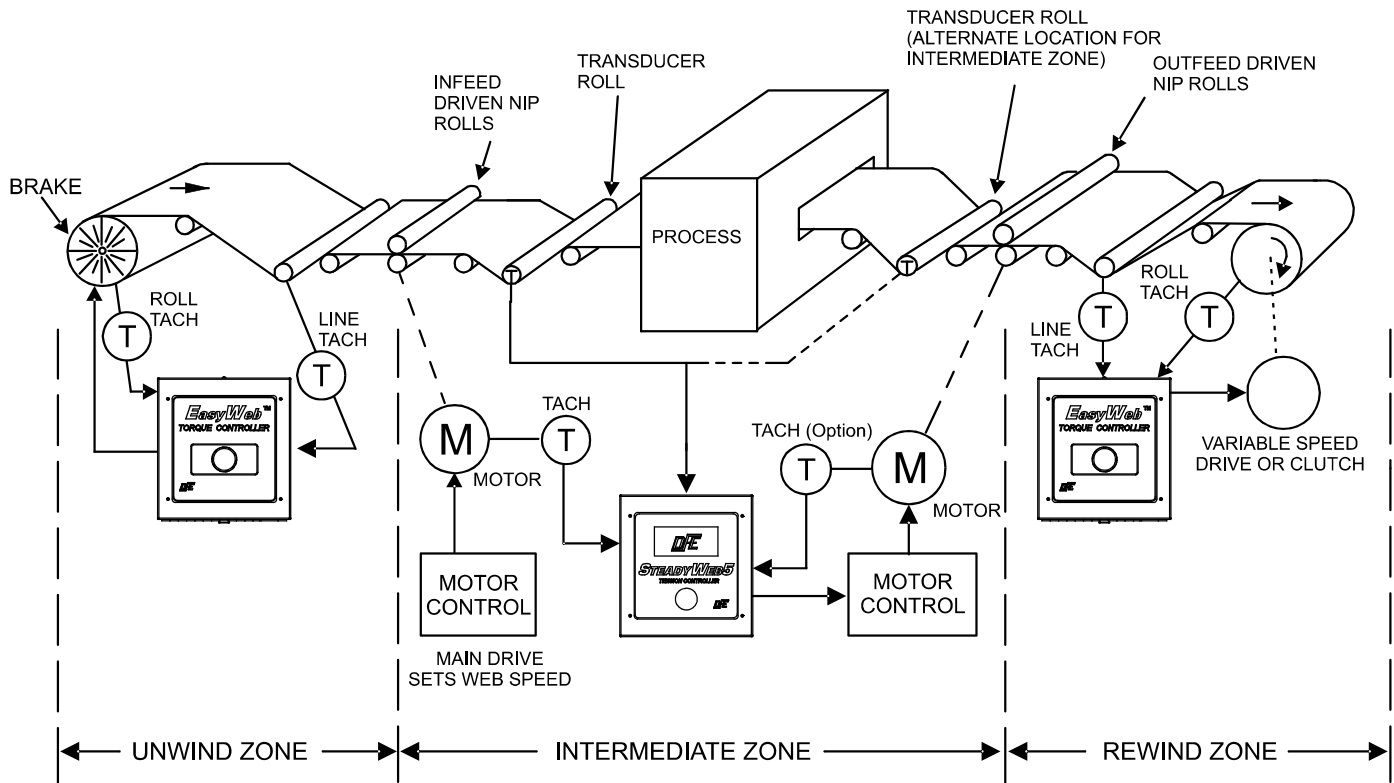

Figure 2 - EXAMPLES OF TENSION ZONES

1.3 VERSIONS OF THE CONTROLLER

The EasyWeb™ controller is available in multiple output, mounting and power configurations as described below.

A. OUTPUT The EasyWeb™ is available with one of three outputs:

- 1. Standard Isolated Output (D).** The standard D version is used to control DC drives or other variable speed drive systems. It offers a jumper selectable voltage or current output. The voltage output is from 0 to 10VDC. The current output uses an industry standard isolated 4 to 20mA signal. The control output is isolated from chassis and ground.

▲ WARNING:

The isolated output is designed to prevent ground loops and noise. It is not intended or approved for safety isolation of hazardous voltages. Do not install unit where the isolated circuit and chassis ground are more than 40Vpk differential.

- 2. Pneumatic Output (P).** The P version is used to actuate any air operated brake or clutch. It includes a servo valve, air filter and pressure regulator installed in a separate enclosure which is fed a 4-20mA signal from the D version of the controller (as described above). The pneumatic output range is 1 to 75 psi (0.07 bar to 5.17 bar). Input air needs to be clean, dry, and at 100 to 125 psi
- 3. High Voltage Output (V).** The V version uses a Silicon Controlled Rectifier (SCR) to produce a standard variable voltage of up to 90VDC to operate any brake or clutch, including eddy current clutches. 45VDC and 24VDC outputs are optional (24VDC not available with 230VAC input). The high voltage output circuitry is housed in a separate enclosure which is fed a 0-10V signal from the D version of the controller (as described above). 115 or 230VAC input required.

1.3 VERSIONS OF THE CONTROLLER *continued...*

B. MOUNTING The controller is available in two mounting configurations.

1. **Open Mount (O).** The Open (panel) mount version can be mounted directly into a cabinet or enclosure cutout.
2. **Enclosure Mount (E).** The enclosed version can be mounted against any surface strong enough to reliably support the controller.

C. POWER The controller is available in two power versions.

1. **24VDC (24).** The DC version is powered from a 24VDC +/-10% supply.
2. **AC (AC).** The AC version includes a universal AC power supply, which can be powered from a 100-240VAC, 50-60Hz supply.

▲ WARNING: AC versions of the EasyWeb™ controller are designed for single phase AC operation only. Do not connect them across three phase lines or to three phase circuits to prevent product damage and potential hazard.

1.4 SPECIFICATIONS

Power Input:

DC: 24VDC +/-10% , 0.6 Amps Typical, 2.2 Amps Internal Fusing (resetting thermal fuse)

Optional AC Supply:

- 100-240VAC +/-10%, 50-60Hz single phase,
- 0.70 Amps @ 115VAC Typical,
- 0.40 Amps @ 230VAC Typical,
- Inrush Current 30A @ 230VAC (cold start)

Digital Inputs:

- Soft Start, Remote On/Off, E-Stop.
- Activated by contact with power ground (falling edge).
- Internal weak pull-up resistors to 3.3VDC.
- Max 24VDC input protection.

Pulse Tachometer Inputs:

Roll Speed, Line Speed.

- Input: 0-50kHz, 1-50VDC pulses

Customer 10/15VDC Supply:

- +10/15VDC (jumper selectable), 50mA max load.

High Voltage Output Module (Version V only):

Power Input:

- 115 OR 230VAC 50/60Hz single phase *Note:* 115 or 230 VAC factory set. Specify when ordering.
- Output Circuitry fused at 5 Amps
- Low Voltage Circuitry fused at 125mA @ 115VAC
- Low Voltage Circuitry fused at 63mA @ 230VAC Output:
- 0 to 24, 45, or 90VDC, all @ 5 Amp with 115VAC In **OR**
- 0 to 45 or 90VDC, all @ 5 Amp with 230 VAC In

Signal Input:

- 0-10VDC Drive signal input from D module

Control Output:

Version D

- 0 to +10VDC OR 4-20mA (jumper selectable), both isolated from input power.
 - 0 to +10VDC max loading is 5mA. This requires a 2000 Ohm or greater input resistance for equipment connected to this output.
 - 4-20mA max loop resistance is 500 Ohms.

Analog Signal Inputs:

- Diameter.
- Designed for 0-10VDC input signal, 0-12VDC range sense capability.
- Max 24VDC input protection.

Optional DC Tachometer Card:

Roll Speed, Line Speed.

- 15-250VDC Input

Optional Enclosure:

- Steel, powder resin painted, NEMA 1

Pneumatic Enclosure (Version P only):

- Air Input: 125 psi Max. 100 to 125 psi. Nominal
- Air Output: 2 to 75 psi (0.14 to 5.17 bar)
- Servo Valve Drive: Signal: 4 to 20mA
- Air Connection In: 3/8" NPT
- Air Connection Out: 1/4" NPT

1.4 SPECIFICATIONS *continued* . . .

Weight:

- DC Panel Version: 1.0 lbs. (0.45 kg)
- AC Panel Version: 1.1 lbs. (0.50 kg)
- DC Enclosure Version: 4.6 lbs. (2.09 kg)
- AC Enclosure Version: 4.7 lbs. (2.13 kg)
- Pneumatic Module: 4.6 lbs. (2.09 kg)
- High Voltage Output Module: 2.9 lbs. (1.32 kg)

1.5 ENVIRONMENTAL CONDITIONS (Ref. Appendix F for further information)

This section applies to equipment designed to be safe at least under the following conditions:

- Indoor use.
- Altitude up to 6500 ft (2000 meters).
- Temperature range: 32° F to 104° F (0° C to 40° C).
- Maximum relative humidity 95% over the temperature range (non-condensing).
- Main supply voltage fluctuations not to exceed +/-10% of the nominal voltage.
- Main supply transient overvoltages according to overvoltage category II of IEC 60364-4-443.
- Pollution Degree 2 in accordance with EN61010-1:2001.

1.6 STANDARD FEATURES

- **Isolated Control Output.** Standard +10VDC or 4-20mA (jumper selectable) isolated control output designed to prevent ground loop and noise issues common in industrial environments.
- **Automatic Control Mode.** The controller output is automatically adjusted with changing roll diameter in order to keep tension constant.
- **Manual Control Mode.** The controller output is manually controlled by changing the MANUAL setpoint value. This mode is used during machine set-up or during troubleshooting.
- **Analog Diameter Input.** 0-10VDC input terminal is provided for a direct roll diameter measurement sensor such as roll follower or ultrasonic range finder.
- **Pulse Tachometer Line and Roll Inputs.** Terminal inputs are provided for line and roll speed pulse tachometer signals. Optional DC tachometer cards can be used to interface with DC tachometers.
- **Taper.** Taper causes the tension to decrease as the roll diameter increases. This is only applicable to rewind zones. The roll diameter is calculated from line and roll tachometer signals or measured directly by a roll follower or ultrasonic sensor. Taper helps produce a better quality roll by eliminating telescoping, crushed cores and too tight or too loose rolls.
- **Soft Start.** Used on braked unwinds. Actuated either automatically by machine speed dropping below a preset speed threshold level (after an adjustable delay), or immediately upon an external contact closure. In Soft Start mode, the controllers output is reduced to a preset (user adjustable) low level to prevent brake lockup when the machine starts. When line speed rises above the threshold level or the Soft Start contact opens, the controller output switches to automatic control mode.
- **Diameter Alarm.** Open collector contact roll diameter alarm output. Used to trigger the alarm output when the roll diameter has crossed a user adjustable roll diameter.
- **Remote On/Off Input.** A terminal block input is provided to toggle either Output On/Off, Auto On/Off, or both. Actuated using external switch or relay.

1.6 STANDARD FEATURES *continued...*

- **Emergency Stop.** Controller immediately goes into full output or minimal output(jumper selectable) upon a break in the Emergency Stop circuit. Normally full output is used on braked unwinds to stop the roll of material quickly, and minimum output is used for motor drive applications. The Emergency Stop circuit can be disabled if no Emergency Stop function is desired.
- **+10/15VDC Customer Supply.** A jumper selectable +10VDC or +15VDC, 50mA supply is provided to power external diameter measurement sensors.

1.7 OPTIONS

- **230 Volt Power (230).** 230 volt 50/60 Hz power input. V version only. (For V-out module, controller can be 24Vdc).
- **24v or 45v Output (24,45).** All for Version V only. 24V available only with 115Vac only.
- **4-20ma Output (420).** 4-20mA current output. This replaces the standard 0-10V control output.
- **DC Tachometer Cards (LDC, RDC).** Used for DC line and roll tachometer inputs.
- **DIN-Rail Mounting Clip (DRC).** Fits 35mm DIN rail. Available only on V version, for V-Out Module.
- **Metric Pneumatic Fittings (MPF).** Metric size air fittings in place of inch size.

1.8 ACCESSORIES

- **Ultrasonic Roll Diameter Sensor.** Compact user-adjustable sensor with a 0-10V output proportional to target distance. P/N 149-0002.

DFE also offers a wide variety of interconnect cables. Please consult your Applications Engineer for more information.

SECTION 2

INSTALLATION

2.1 DIMENSIONS OF STANDARD UNIT inches (mm)

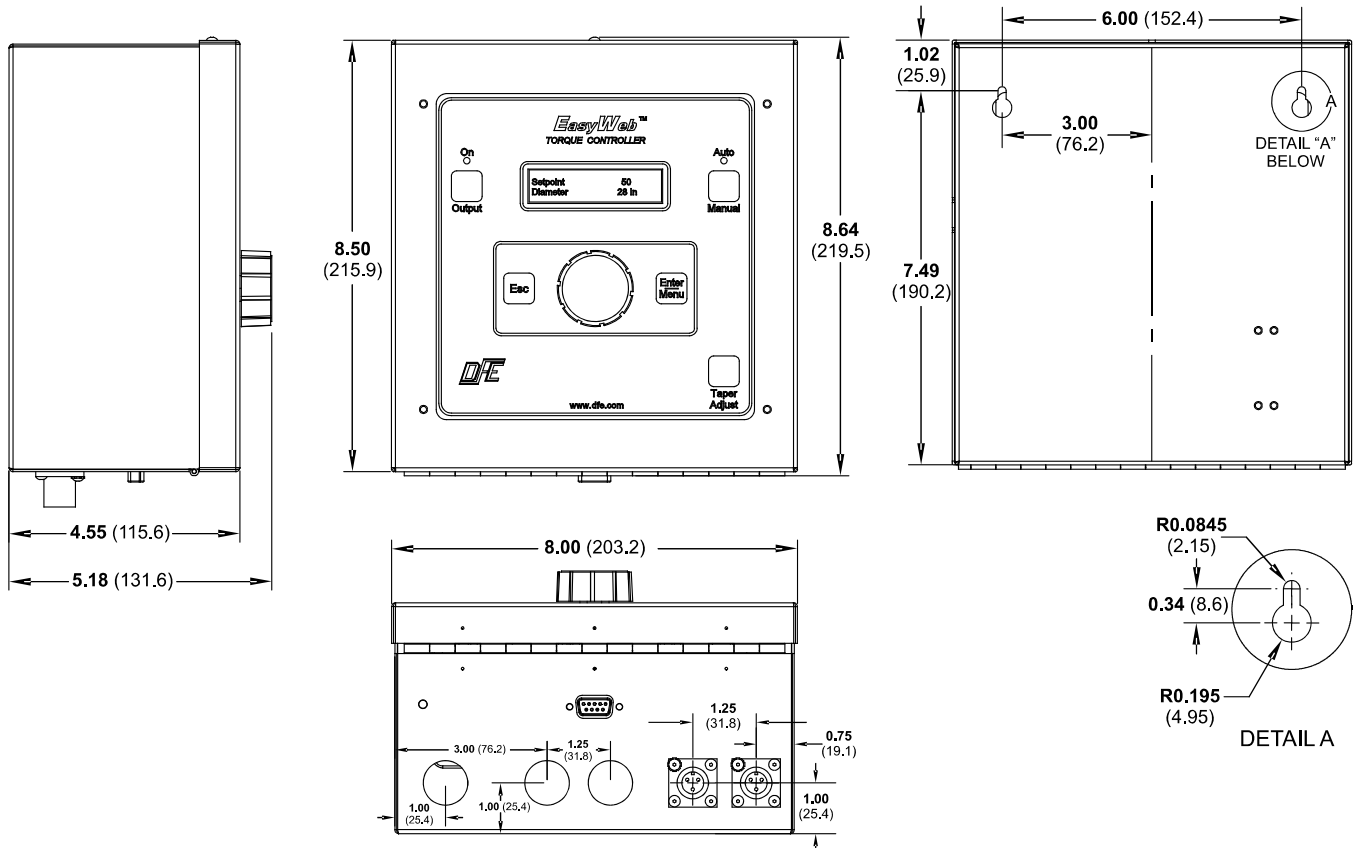

Figure 3 - ENCLOSURE VERSION DIMENSIONS and VIEWS

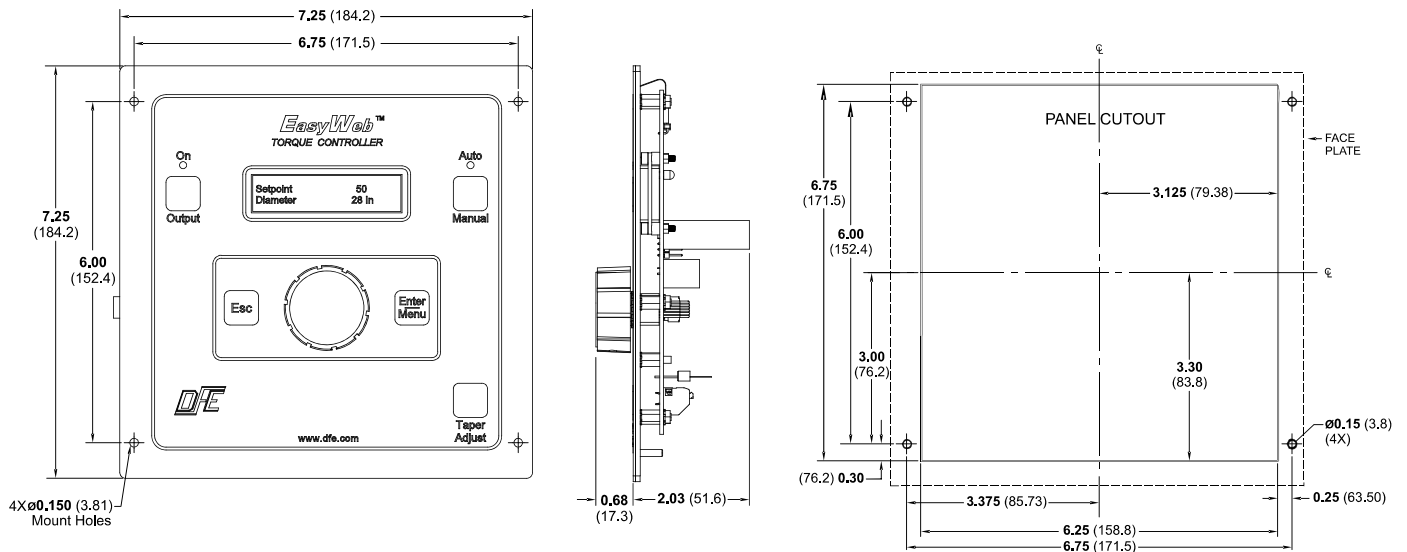

Figure 4 - OPEN (PANEL) VERSION DIMENSIONS and VIEWS

2.1 DIMENSIONS *continued*.... inches (mm)

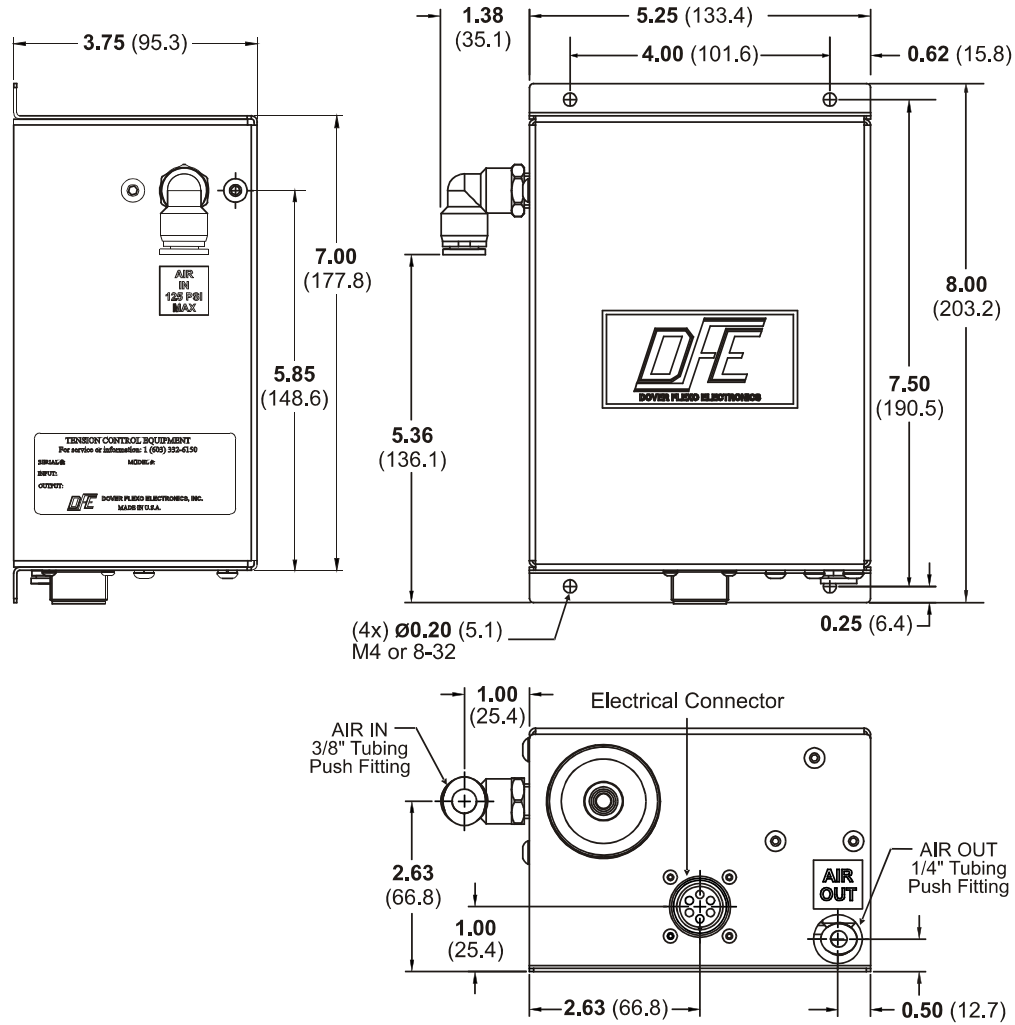

Figure 5 - PNEUMATICS ENCLOSURE DIMENSIONS FOR VERSION P

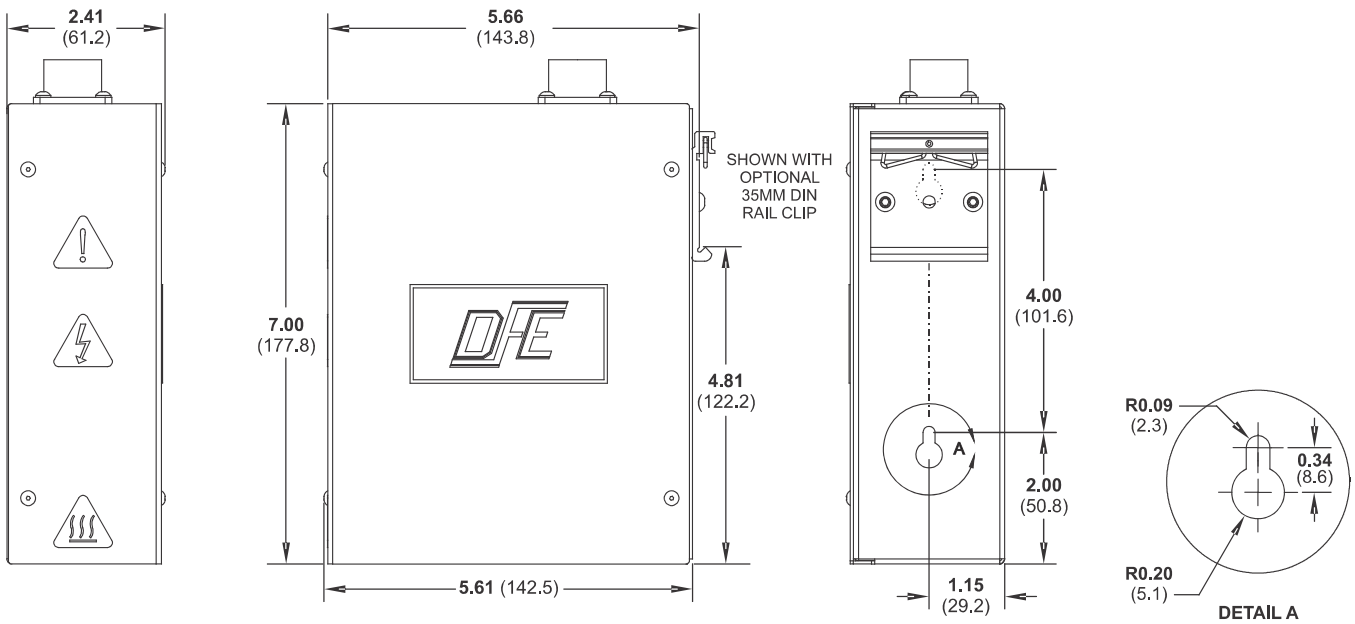

Figure 6 - HIGH VOLTAGE OUTPUT ENCLOSURE DIMENSIONS FOR VERSION V

2.2 SELECTION OF A MOUNTING LOCATION

1. Enclosure Mount Versions

Select a mounting location on the machine frame or a wall that will provide convenient operator interaction and easy screen viewing. To ensure safety and proper operation, the EasyWeb must be located away from dusty or wet environments. The unit should be mounted to a secure wall or surface that can support in excess of 30 lbs. (13.6 kg). As the controller's front panel is hinged to the bottom of the enclosure, ensure that the mounting location will allow the front panel to swing open and down unobstructed. In addition, ensure there will be adequate room below the controller to allow for wire routing.

2. Open (Panel) Mount Versions

The open mount configuration should be installed in a cabinet or enclosure that can support in excess of 15 lbs. (6.8 kg). The controller should be positioned for convenient operator interaction and easy screen viewing. To ensure safety and proper operation, the EasyWeb™ must be located away from dusty or wet environments. Ensure there is a minimum of 5" (12.7 cm) clearance behind the mounting panel to allow for physical fit of the controller with room for air circulation. In addition, ensure there will be adequate room below the controller's mounting location to allow for wire routing to the input/output terminal blocks.

3. Version P Only

The pneumatic enclosure is designed for mounting close to your brake or clutch. This allows for a short length of tubing between the pneumatic output and the brake or clutch. In addition to a shop air supply connection, a signal cable must be run between the pneumatic unit and the controller. Choose a location which is free from vibration and that is located away from dusty or wet environments. The pneumatic enclosure should be mounted upright to a secure wall or surface that can support in excess of 20 lbs. (9.1 kg). Ensure there will be adequate room around the mounting location for wire and pneumatic tube routing. Air should be clean and dry - no oil.

4. Version V Only

The High Voltage output enclosure is designed for mounting close to your electric brake or clutch. It requires a dedicated AC power feed. In addition, a signal cable must be run between the Vout module and the controller. To ensure safety and proper operation, the V-Out enclosure must be located away from dusty or wet environments. It should be mounted to a secure wall or surface that can support in excess of 12 lbs. (5.5 kg). Ensure there will be adequate room around the mounting location for wire routing.

2.3 SAFETY AND EMC REQUIREMENTS

▲ WARNING: If this equipment is not connected or operated in the manner specified, the operating safety of this unit or of connected equipment cannot be guaranteed.

▲ WARNING: The isolated output is designed to prevent ground loops and noise. It is not intended or approved for safety isolation of hazardous voltages. Do not install unit where isolated circuit and chassis ground are more than 40V_{pk} differential.

▲ WARNING: AC versions of the EasyWeb controller are designed for single phase AC operation only. Do not connect them across three phase lines or to three phase circuits to prevent product damage and potential hazard.

1. AC Power Configuration

For safety reasons, it is necessary to use appropriate wiring for your line voltage connections and for safety grounding. Make your ground connection between a reliable earth ground and the safety ground of your controller using a wire with a gauge of at least 16 AWG (or a cross-sectional area of at least 1mm²) and insulation rating of at least 600V.

Make your AC line voltage connections with wire gauge of at least 16 AWG (or a cross-sectional area of at least 1mm²) and insulation rating of at least 600V for each conductor.

2. DC Enclosure Mount Configuration

For DC enclosure mount units, the length of wire inside the enclosure should be long enough to allow the front panel to open fully without putting any strain on wire, but no longer. Flexible, stranded wire should be used to allow flexing around the enclosure hinge when opening and closing the front panel.

2.3 SAFETY AND EMC REQUIREMENTS *continued...*

Solid wire should not be used. Be sure to route the 24VDC power supply wires through the side cable clamp as shown in **Figure 10, 24VDC Power Electrical Connections**.

3. AC and DC Power Configurations

Secure the power wiring to prevent inadvertent removal or strain on the input terminal. For enclosure mount units, this wiring should be secured at the power inlet of the enclosure. An external switch or circuit breaker is required for power disconnection of the EasyWeb™. It is recommended that this switch or circuit breaker be located near the equipment and be well labeled.

4. Version V Only

For safety reasons, it is necessary to use appropriate wiring for your line voltage connections and for safety grounding. Make your ground connection between a reliable earth ground and the safety ground of your V-Out module using a wire with a gauge of at least 12 AWG (or a cross-sectional area of at least 2mm²) and insulation rating of at least 600V.

Make your AC line voltage connections with wire gauge of at least 12 AWG (or a cross-sectional area of at least 2mm²) and insulation rating of at least 600V for each conductor. Secure this wiring to prevent inadvertent removal or strain on the input terminal.

An external switch or circuit breaker is required for power disconnection of the V-Out module. It is recommended that this switch or circuit breaker be near the equipment, and be well labeled.

It is necessary to remove the V-Out Module cover (held in place by four M3 screws) to mount the output module to a supportive wall. It is also necessary to remove the cover to access and wire into the module's terminal blocks. Always remove power before removing the V-Out Module's cover. The cover should never be removed while power is supplied to the device. The V-Out module cover should always be attached and firmly tightened down when power is supplied to the unit.

▲ WARNING: Always keep the V-Out Module enclosure closed with the cover firmly tightened down while power is attached to the module.

5. Shielding

Cable shielding must be attached to a SHIELD connection on the terminal blocks, or to an appropriately grounded enclosure. All input cables should be shielded.

6. Enclosure Mount Versions

Enclosure mount versions of the EasyWeb™ controller use a hinged enclosure. The front of the controller hinges down to allow access to the internal circuit boards and adjustments. The enclosure should always be mounted in a location that allows unobstructed opening and closing of the front panel. When the front panel is closed, an M3 screw on the top of the enclosure must be tightened down to firmly keep the panel in place and prevent unintentional opening (see **Figure 7, Enclosure Version Service Access**). The panel should be kept shut with the latch screw tight at all times when the controller is in use. Only qualified service technicians may open the enclosure and access the internal circuit boards.

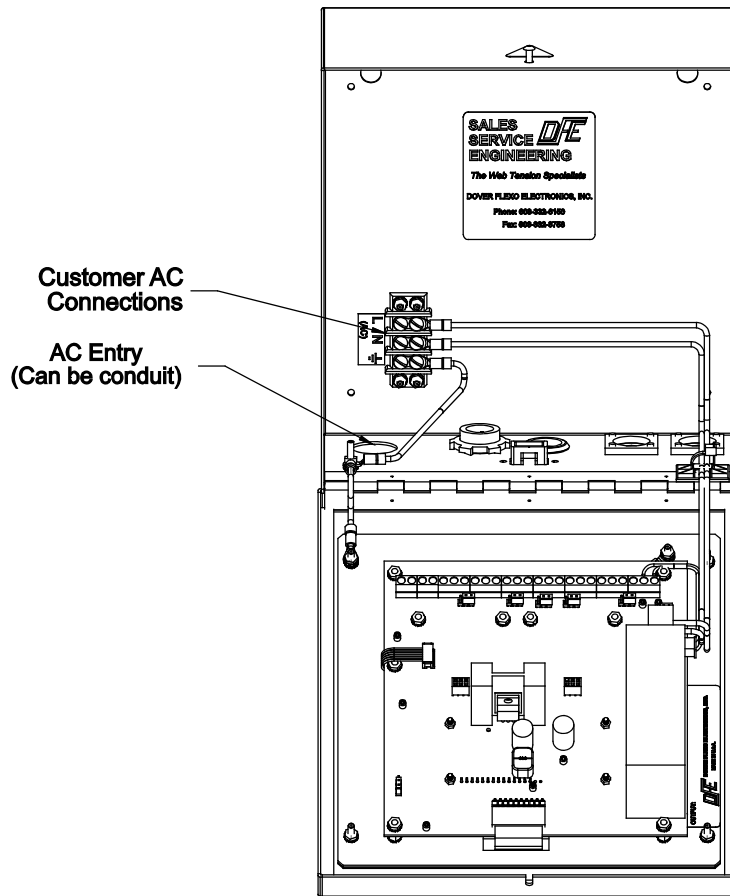

Figure 7 – ENCLOSURE VERSION SERVICE ACCESS

2.4 INSTALLATION INSTRUCTIONS

1. Open (Panel) Versions

For open mount units, drill four M3 (#4) clearance (0.140" / 3.5mm) holes in a 6.75" (17.15 cm) horizontal by 6" (15.24 cm) vertical rectangle. Cut an opening centered in the holes measuring 6.25" (15.88 cm) across by 6.75" tall, (16.13 cm) (see Section 2.1, Fig. 4-Panel Mount Dimensions and Views). Mount your Panel style controller in the hole using four M3 (#4) nuts and screws.

2. Enclosure Versions

For enclosure mount units, drill and tap two M4 (#8) holes 6.00" (15.24 cm) apart horizontally and 7.49" (19.02 cm) up from the desired bottom of the enclosure to match the screw hole dimensions on the back surface of the EasyWeb™ enclosure (see Section 2.1, Fig. 4-Enclosure Mount Dimensions and Views). The enclosure is fastened to the mounting surface you have chosen by two M4 (#8) screws. Install the screws on the mounting surface. Leave the screws loose about 6 turns. Position the keyholes in the back panel of the enclosure over the screws and slide it down until it locks in place. The cover must be open to tighten the mounting screws and secure the enclosure in place.

3. Version P Only

The pneumatic enclosure should be located in the area of your clutch or brake. Drill and tap four M3 (#4) holes in a 4" (10.16 cm) horizontal by 7.5" (19.05 cm) vertical rectangle (see Section 2.1, Fig. 5-Pneumatic Enclosure Dimensions).

The enclosure is fastened to the mounting surface you have chosen by four M3 (#4) screws. The pneumatic servo is sensitive to any mounting off it's vertical axis. Mounting off vertical axis can cause error in output pressure.

2.4 INSTALLATION INSTRUCTIONS *continued...*

4. Version V Only

The High Voltage Output module should be located in the area of your clutch or brake. If you are using the DIN clip style, the V-out module may simply be clipped to a DIN rail. If you are using the Enclosure mount style, drill and tap two M4 (#8) holes 4.0" (10.16cm) apart vertically with the lower hole 2" (5.08cm) up from the desired bottom of the enclosure to match the screw hole dimensions on the back surface of the V-Out enclosure (see Section 2.1, Fig. 6-High Power Module Dimensions). The enclosure is fastened to the mounting surface you have chosen by two M4 (#8) screws. Install the screws on the mounting surface. Leave the screws loose about 6 turns. Position the keyholes in the back panel of the enclosure over the screws and slide it down until it locks in place. The cover must be open to tighten the mounting screws and secure the enclosure in place. This module is not sensitive to mounting at any angle.

2.5 CONTROL OUTPUT SELECTION

This has been factory set to match your order. The following instructions are used to reconfigure the controller for an alternative use.

The isolated control output can be configured for either 0-10V output or 4-20mA output by setting jumpers JP1 and JP2 located between the AC power input and main terminal block (refer to **Figure 8, Output Jumpers**). If voltage output is required, place jumpers on pins 2 and 3 (labeled 0-10V) on both JP1 and JP2. If 4-20mA output is required, place jumpers on pins 1 and 2 (labeled 4-20) on both JP1 and JP2.

NOTE: Both jumpers must be in the same position for proper operation.

When set to voltage mode, the controller is capable of producing a 0-10V control signal. The output, in both current and voltage mode, is isolated from chassis and transducer ground. This prevents ground loops and related noise issues which can be common in industrial environments.

▲ WARNING: The isolated output is designed to prevent ground loops and noise. It is not intended or approved for safety isolation of hazardous voltages. Do not install unit where the isolated circuit and chassis ground are more than 40Vpk differential.

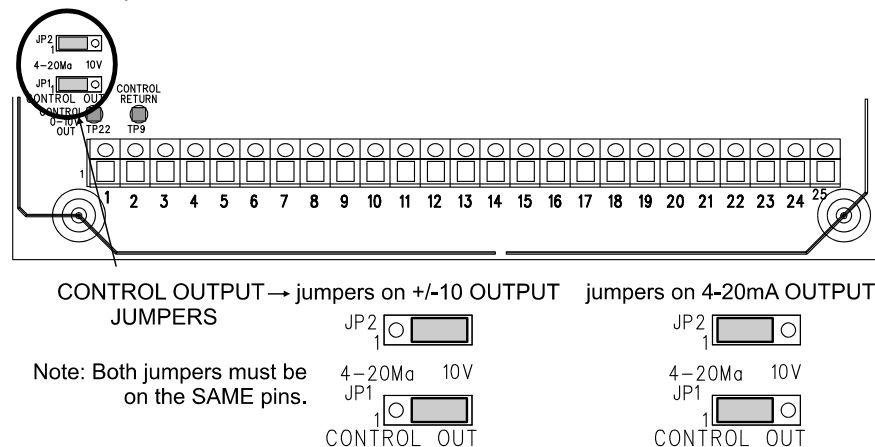

Figure 8 - CONTROL OUTPUT JUMPERS

2.6 EMERGENCY STOP CONFIGURATION

The Emergency Stop feature is useful for stopping large rolls of material when an external normally closed switch, contact or relay is opened. The circuit requires an external switch, contact or relay to be connected to the Main Terminal Block (TB1) terminal 10 (E-STOP) and terminal 9 (E-Stop Return) (see Section 2.9, Standard Electrical Connections). Terminal 10 (E-Stop) supplies approximately +3.3VDC, which must be returned to terminal 9 (E-Stop Return). If a break in the Emergency Stop circuit should occur, the Emergency Stop output circuit will activate.

The Emergency Stop circuit can be enabled or disabled with jumper JP3 (see **Figure 9, Setup Jumpers**). To Enable the Emergency Stop circuit, set the JP3 jumper to pins 2 and 3 (labeled ENABLE). To disable the Emergency Stop circuit, set the jumper to pins 1 and 2 (DISABLE).

2.6 EMERGENCY STOP CONFIGURATION *continued...*

When the Emergency Stop circuit is active, the control output will produce either a zero (0V or 4mA) or full output (10V or 20mA) signal based upon jumper JP4 (see **Figure 9, Setup Jumpers**). Full output is traditionally used in braked unwind applications to stop the roll of material quickly. Minimum output is used for other applications. To set the Emergency Stop output to zero, set the jumper to pins 2 and 3 (labeled LOW) on JP4. To set the Emergency Stop output to full output, set the jumper to pins 1 and 2 (labeled HI) on JP4.

During an Emergency Stop condition an “E-STOP ACTIVE” message is shown on the display. The E-STOP display is active until the Emergency Stop condition is removed. The Menu screens are not accessible during an E-STOP condition.

In addition to the required Emergency Stop electrical connections and jumper settings, the “**Output OffbyESTOP**” setting, located in the *Setup Menu* allows the user to specify whether the output will remain On during an Emergency Stop condition (to pick up control after the Emergency Stop condition is removed) or whether it will be forced Off (forcing the operator to re-engage the output after an Emergency Stop condition).

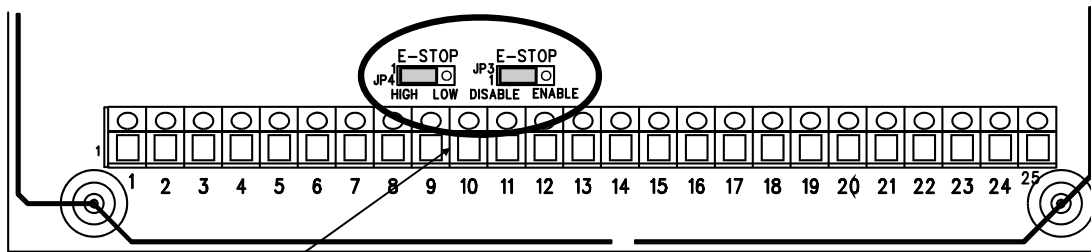

jumpers for E-STOP

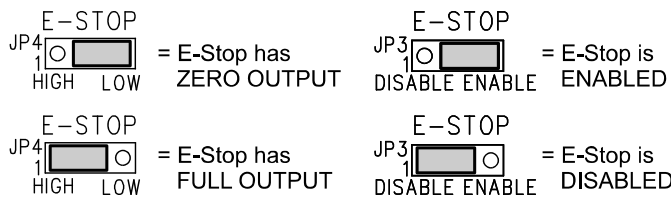

Figure 9 – E-STOP SETUP JUMPERS

2.7 CUSTOMER +10/15V OUTPUT SELECTION

A selectable 10VDC or 15VDC supply is provided for customer use. This supply is designed to power light loads, such as a roll follower or ultrasonic rangefinder. It should not be used for loads pulling greater than 50mA. The supply can be accessed via the main terminal block (TB1) terminal 5 (+10/+15V) and terminal 6 (GROUND) (see Section 2.9, Standard Electrical Connections).

The 10V or 15V selection is made by jumper JP6 (see **Figure 9, Setup Jumpers**). Placing the jumper on pins 1 and 2 (labeled 10V) sets the voltage rail to 10V. Placing the jumper on pins 2 and 3 (labeled 15V) sets the voltage rail to 15V.

2.8 POWER ELECTRICAL CONNECTIONS

Make wiring connections as follows:

1. The insulation rating of all line voltage wiring must be at least 600V.
2. Keep line voltage wiring physically separated from signal wiring at the terminal block and at any other point in the installation.
3. Keep all wiring away from devices emitting electromagnetic radiation.

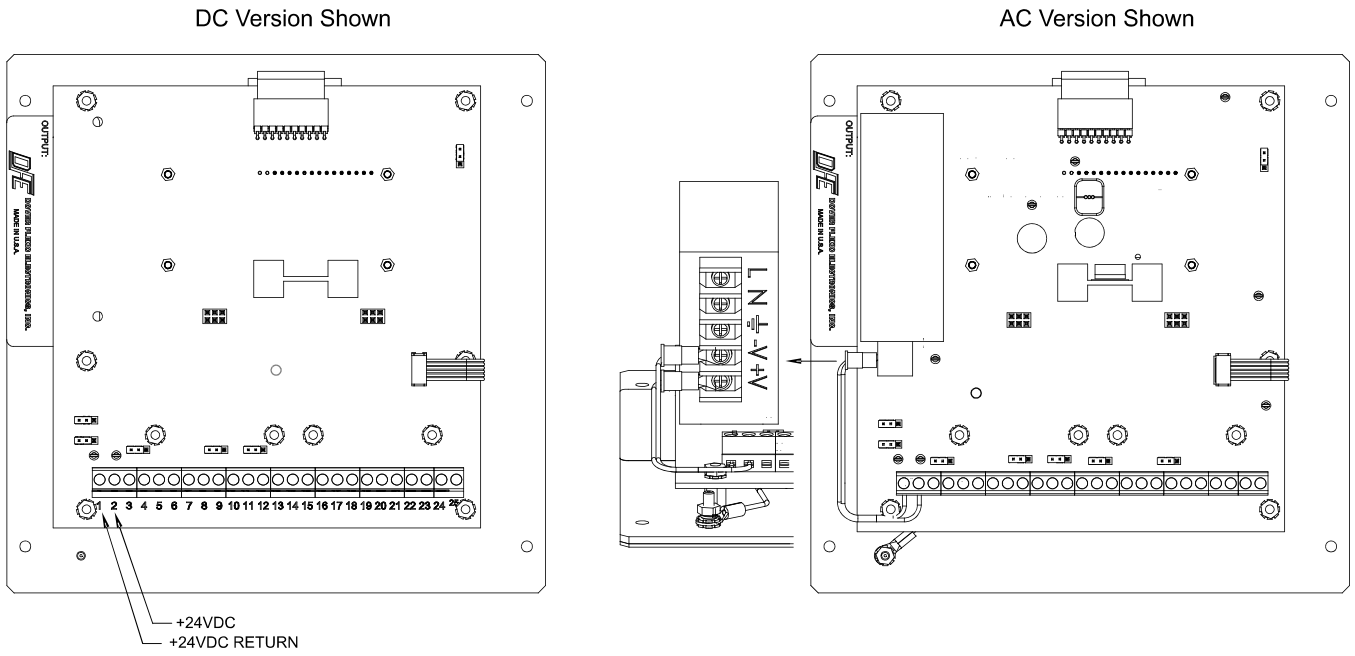

Figure 10 – 24VDC AND AC POWER ELECTRICAL CONNECTIONS

2.9 STANDARD ELECTRICAL CONNECTIONS

Make your wiring connections as follows:

1. Keep all wiring away from devices emitting electromagnetic radiation.
2. Connect cable shields to the closest Shield terminal on the relevant terminal block. Only connect signal cable shields on one end to avoid ground loops.

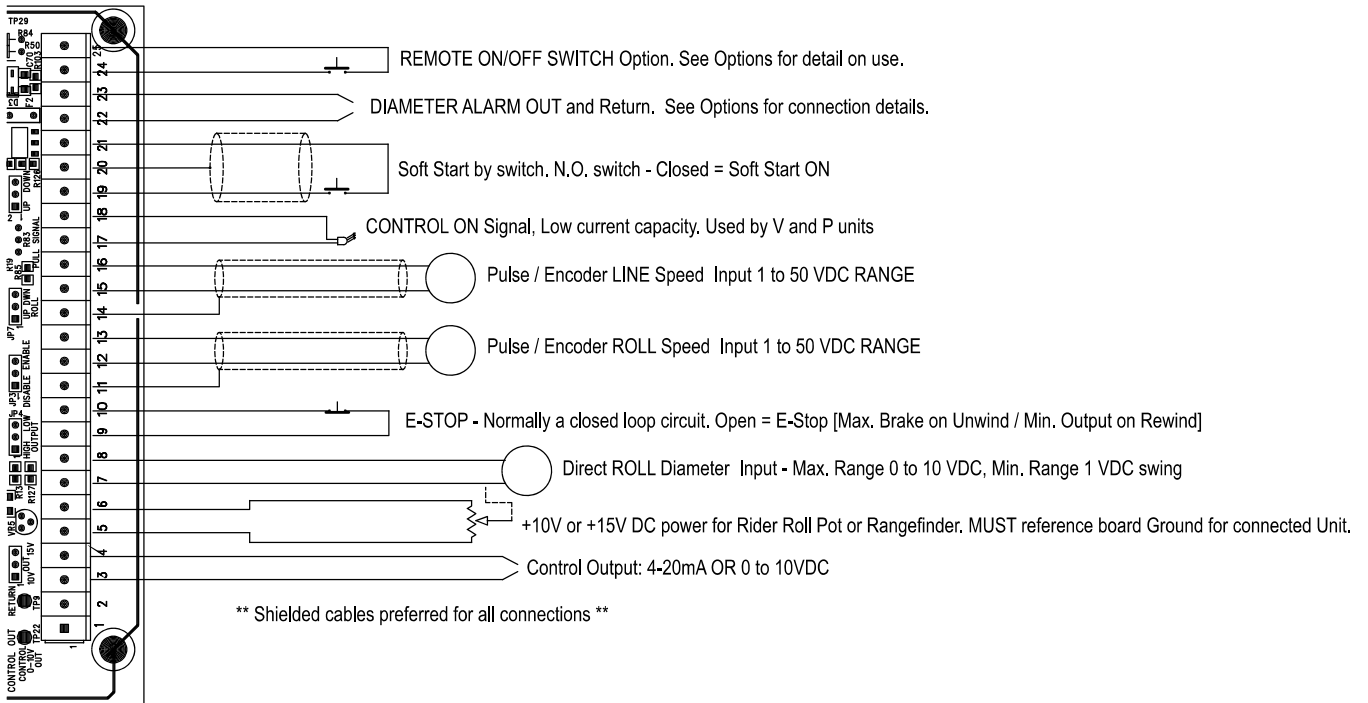
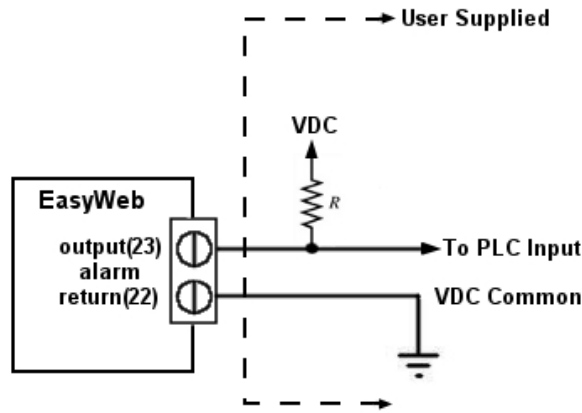

Figure 11: STANDARD AND 0-10V CONTROL BOARD ELECTRICAL CONNECTIONS

STANDARD ELECTRICAL CONNECTIONS continued

1. PLC Connection



Note: R typically 5-10Kohm

2. External Indicator Connection

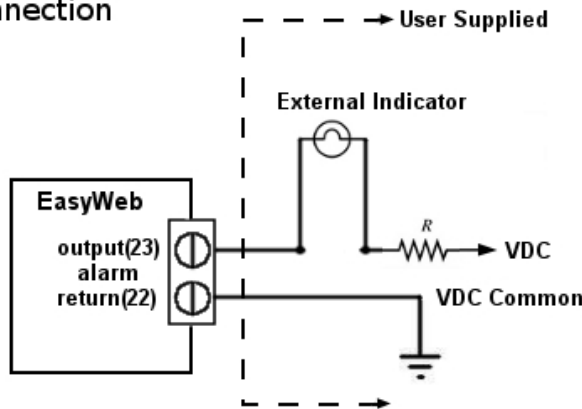

3. Relay Connection

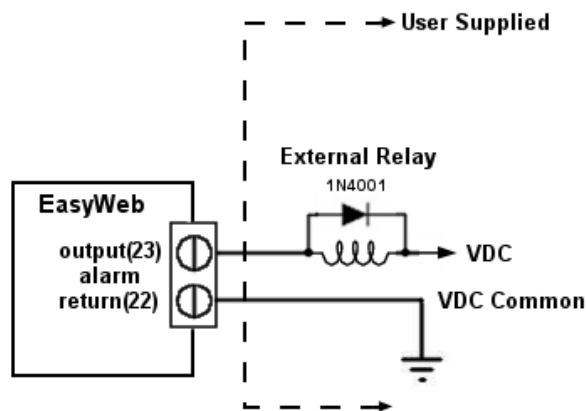

Note: Relays must have a 1N4001 or equivalent diode across the coil as shown.

Figure 12 - DIAMETER ALARM CONNECTIONS

2.10 OPTION CARD MOUNTING LOCATIONS

The EasyWeb™ can accept line and roll speed signals from a DC tachometer using optional DC tachometer cards. The control board provides two sets of plugs and mounting hole locations for this purpose labeled “DC ROLL” and “DC LINE”, respectively. The Option cards are installed as specified per order at the factory.

***Note:** the *pulse line* and *pulse roll* inputs on the main terminal block(TB1) are for pulse tachometer signals only. DC tachometer signals must be wired to the DC tachometer cards.

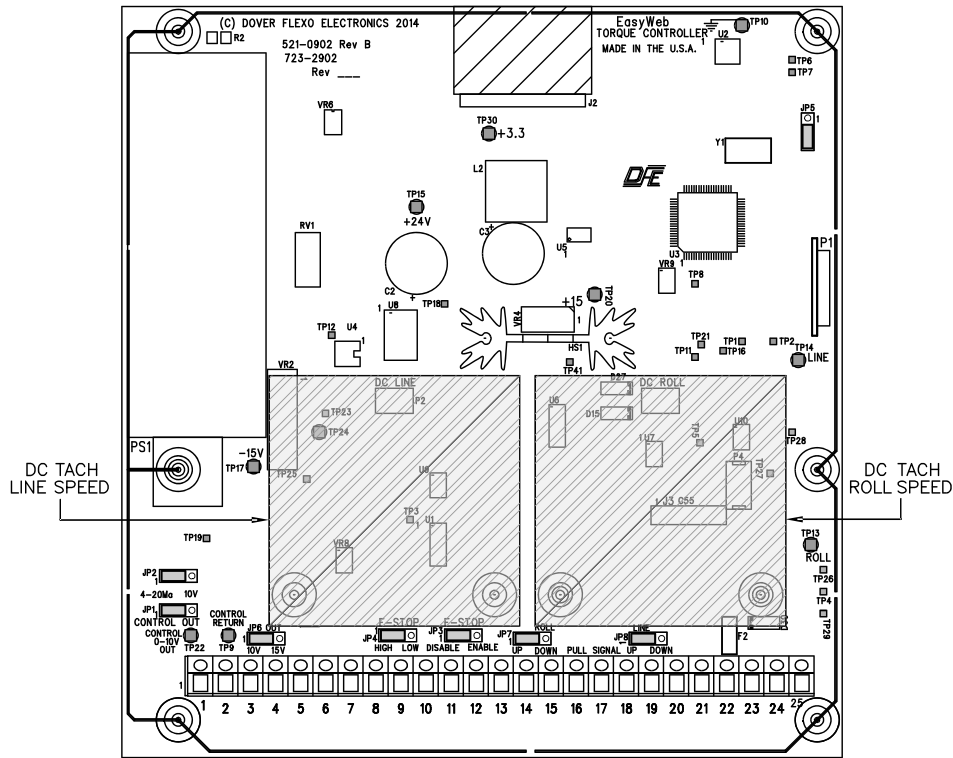

Figure 13 - OPTION CARD MOUNTING LOCATIONS

2.11 DC TACHOMETER OPTION CARD ELECTRICAL CONNECTIONS

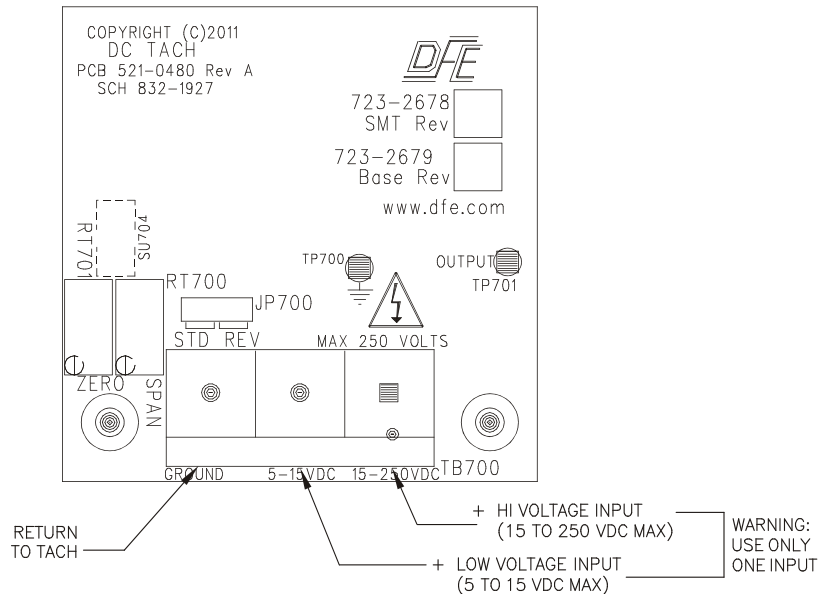

Figure 14 – DC TACHOMETER ELECTRICAL CONNECTIONS

2.12 EXTERNAL OUTPUT MODULE CABLE CONNECTIONS

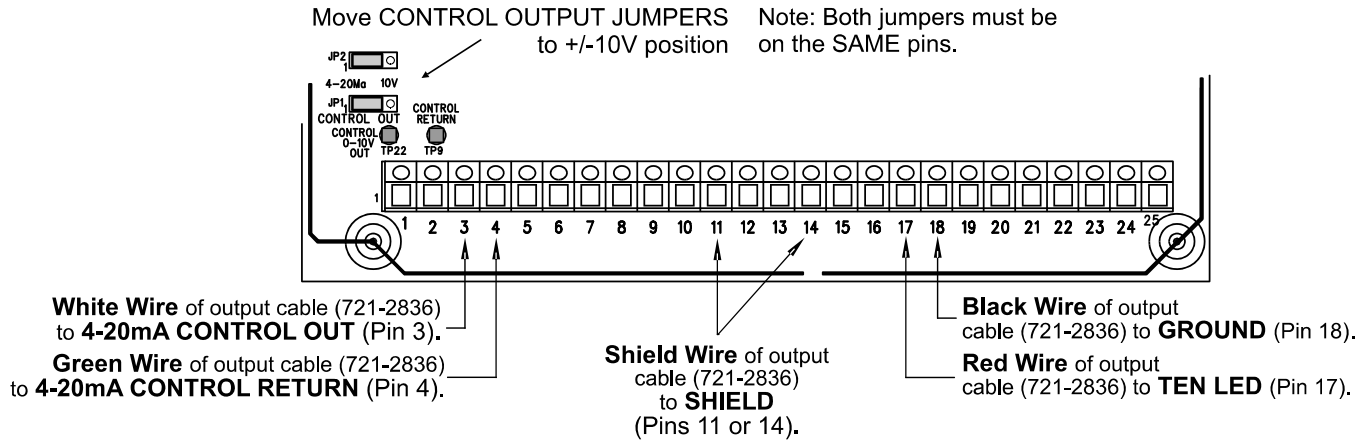

Figure 15 – EXTERNAL OUTPUT MODULE CABLE CONNECTIONS

2.13 HIGH VOLTAGE OUTPUT MODULE ELECTRICAL CONNECTIONS

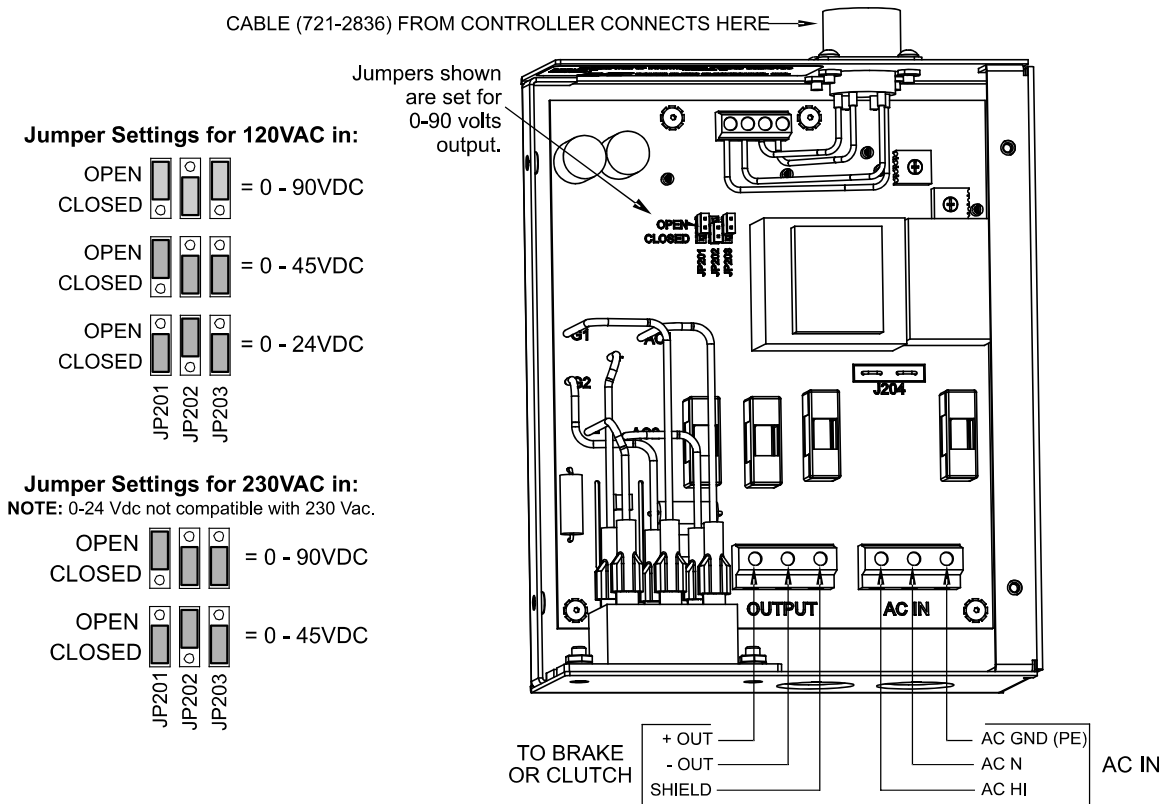

Figure 16– HIGH VOLTAGE OUTPUT MODULE ELECTRICAL CONNECTIONS

Your EasyWeb™ controller has been properly configured at the factory. It should not be necessary to make any changes except calibration. Use this section to verify the configuration or to reconfigure the controller if your application requirements change.

Line speed, roll speed, and direct diameter are the three signals that may require calibration depending on the mode and features you will be using. For example, if using the EasyWeb™ with a direct diameter sensor there is no need to calibrate line or roll speed signals since those are typically used to calculate diameter in place of a direct diameter sensor. A table showing the applicable calibration requirements for various modes and features is shown below.

	Direct Diameter Mode	Tach Ratio Calc Mode	Inertia Comp. feature	Soft Start by Line speed feature
Line Speed Signal	N/A	Calibration Reqd.	Calibration Reqd.	Calibration Reqd.
Roll Speed Signal	N/A	Calibration Reqd.	N/A	N/A
Direct Diameter Sensor	Calibration Reqd.	N/A	N/A	N/A

3.1 DIAMETER INPUT CALIBRATION

There are two ways the EasyWeb™ can determine roll diameter.

1. Directly from a diameter measurement device, such as from a rider assembly or ultrasonic sensor.
2. As an internally calculated diameter based on the ratio of the Line speed to Roll speed inputs. This mode requires valid Line and Roll speed inputs, which may need to be individually calibrated (see section, 3.1 Line/Roll Speed Input Calibration).

1. Direct Diameter Input

The Diameter input is designed to take a signal from a rider assembly, ultrasonic sensor or other diameter measurement device that has an output that falls between 0 and 10VDC. The minimum voltage variation between core diameter and full roll diameter should cause at least 4V of change. When using a rider assembly, ensure the rider moves freely over the entire range of roll diameters. When using an ultrasonic sensor, ensure the ultrasonic beam is aimed perpendicular to the winding roll, not at an angle.

The diameter signal should be wired directly into the control board's main terminal block (TB1) terminal 7 (0-10V DIA) and 8 (GROUND) (see Section 2.9, Standard Electrical Connections). A user selectable +10V or +15V power supply is available for driving light loads such as a roll follower potentiometer or ultrasonic range finder (see Section 2.7 Customer +10/15V Output Selection).

To set the EasyWeb™ in direct diameter mode, navigate to the *Setup Menu > Diameter Input* menu and set the **Diameter Input** setting to **Direct**. Next, navigate to the *CALIBRATION MENU > CAL CORE DIAM* to calibrate the core diameter. The calibration screen displays the following message, “SENSOR TO CORE & PRESS ENTER”, following the calibration screen prompt, place an empty core in the machine and lower the roll follower or activate the range finder and press “ENTER” button. The “CAL COMPLETE, ENTER TO CONTINUE...” message screen will appear indicating a successful core calibration.

3.1 DIAMETER INPUT CALIBRATION *continued...*

To calibrate the maximum diameter, navigate to *CALIBRATION MENU > CAL MAX DIAM*, the controller will ask you to calibrate the full roll diameter. The calibration screen displays the following message, “SENSOR TO FULL & PRESS ENTER”, following the calibration screen prompt, load a roll on the machine with the maximum used diameter and lower the roll follower or activate the range finder and press “ENTER” button. The “CAL COMPLETE, ENTER TO CONTINUE...” message will appear indicating a successful full roll calibration. If the calibration was unsuccessful an error message is returned. This usually indicates the signal change from core to max diameter is too small.

2. Tachometer Ratio Calculation

Tachometer ratio calculation determines the roll diameter by monitoring the ratio of the Line Speed to Roll Speed inputs and taking into consideration that as diameter increases, a slower rotation is required for a given speed. For example, if the Roll input signal is half that of the Line input signal, the diameter of the Roll will be twice that of the core diameter.

To set the EasyWeb in tachometer ratio mode, navigate to the *Setup Menu > Diameter Input* menu and set the **Diameter Input** setting to **Tach Ratio Calc**. To use the Tachometer Ratio Calculation mode, Line and Roll inputs must be present and calibrated (see section, 3.1 Line/Roll Speed Input Calibration).

Note: The diameter displayed should agree with the actual measured diameter within at most 10%, preferably within 5%. If this is not the case, re-perform calibration as described above.

3.2 LINE/ROLL SPEED INPUT CALIBRATION

The Line Speed represents the actual speed of the web, and is useful for tachometer ratio diameter calculation and inertia compensation. It is usually determined by a tachometer reading an idler roll's spinning rate.

The Roll Speed represents the speed of a rotating roll, either in an Unwind or Rewind system. It again, is typically determined by a tachometer signal measuring the roll's spinning rate. The Roll Speed is used together with the Line Speed to calculate a roll's diameter (see Section 3.4 Diameter Input Calibration, for more information).

There are two ways to feed a Line or Roll speed signal to the EasyWeb™ controller:

1. A 0-250VDC signal representing speed from an external DC Tachometer.
2. A 1-50VDC pulsed signal representing speed from an external Pulse Tachometer Encoder.

1. Pulse Tachometer Input

Inputs from a Pulse Tachometer are wired directly to the main terminal block(TB1). Line speed pulse tachometer signals must be wired to terminal 15 (+ Pulse Line), and terminal 16 (-Pulse Line) of TB1. Roll speed pulse tachometer signals must be wired to terminal 12 (+Pulse Roll), and terminal 13 (-Pulse Roll) of TB1. Pull-up and pull-down resistors are provided for pulse tachometers that require external resistors to generate a useable pulse signal. Generally NPN (Sinking) outputs should be pulled-up to power, while PNP (Sourcing) outputs should be pulled-down to ground. Jumpers JP7 and JP8 are used to select between pull-up or pull-down for the roll and line signals, respectively.

If calibrating the Line speed input, the **Max Line Speed** setting in the *Setup Menu > Line Speed Setup* menu should be set to the maximum Line speed value and the **Line Speed Units** setting should be set to the desired line speed display units.

2. DC Tachometer Input

Input from a DC Tachometer requires a DC Tachometer Input option card (P/N 723-2085). For a Line Speed input, this card must be installed into the DC LINE slot on the control board (plugging into P2) and mounted properly to the two supportive mounting studs (see Section 2.10, Figure 13, Option Card Mounting Locations). For a Roll Speed input, the card must be installed into the DC ROLL slot on the control board (plugging into P3) and mounted properly to the two supportive mounting studs (see Section 2.10, Figure 13, Option Card Mounting Locations).

For instructions on how to calibrate the DC Tachometer input option card, refer to Section 3.2, DC Tachometer Calibration.

3.2 LINE/ROLL SPEED INPUT CALIBRATION *continued...*

If calibrating the Line Speed input, the **Max Line Speed** setting in the *Setup Menu > Max Line Speed* menu should be set to the maximum Line Speed value and the **Line Speed Units** setting should be set to the desired line speed display units.

3.3 DC TACHOMETER CALIBRATION

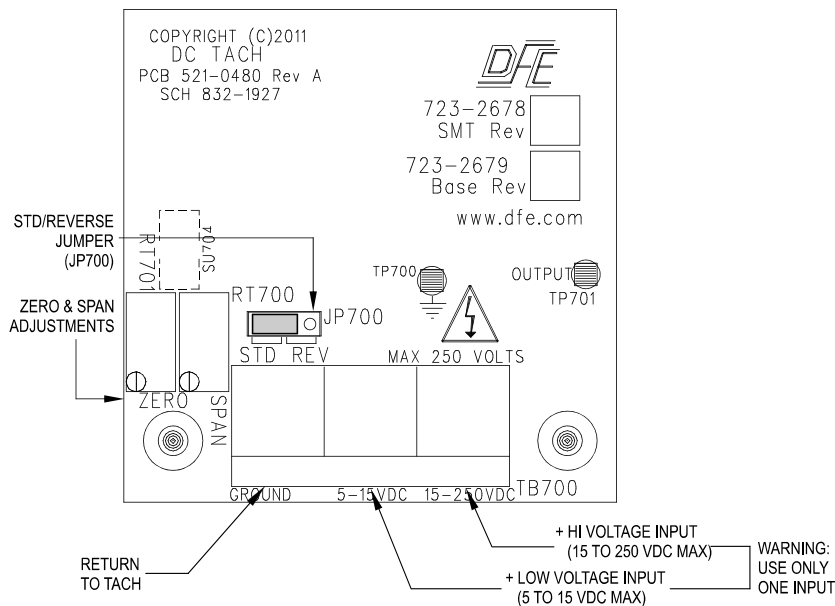

Figure 17 – DC TACHOMETER CARD ELECTRICAL CONNECTIONS & ADJUSTMENTS

The optional DC Tachometer input card accepts a DC input voltage from a tachometer with a maximum output voltage between 5 and 250VDC and converts it to a 0-10VDC signal which gets passed down to the controller board.

For DC tachometers that output a maximum output voltage between 5 and 15VDC, the positive tachometer output lead should be connected to terminal 2 of the DC Tachometer input card terminal block (TB700). Tachometers with a maximum output voltage between 15 and 250VDC should connect the positive tachometer output to terminal 3 of the DC Tachometer input card terminal block (TB700). The negative tachometer output should be connected to terminal 1 (GROUND) of the DC Tachometer input card terminal block (TB700) (see Fig. 17 above).

With the tachometer properly wired to the DC Tachometer input card and power applied to the controller, attach the positive clip lead (or probe) of a DC Voltmeter to test point TP701 (OUTPUT) and the negative clip lead (or probe) to test point TP700 (GROUND) on the DC Tachometer input card (see **Figure 17 above**).

With the machine at zero speed, the output at the Voltmeter should read 0.0V. If not, adjust the RT701 (ZERO) potentiometer until the output voltage reads 0.0V. (see **Figure 17 above**).

Run the machine at max speed, or optionally at 50% max speed and note the polarity of the output at the Voltmeter. If the polarity is negative, swap the location of jumper JP700 from STD (standard) to REV (reverse) (see **Figure 17 above**).

Use a hand tachometer to verify the machine is running correctly at maximum speed (or at 50% speed if desired).

Next, the RT700 (SPAN) potentiometer must be adjusted on the DC Tachometer input card to create the desired output at the Voltmeter. When calibrating a Line Speed tachometer or a Roll tachometer at core diameter, the SPAN potentiometer should be adjusted to match the machine speed. For example, if running the machine at max speed, the SPAN potentiometer should be adjusted for a 10.0V output at the Voltmeter. If running the machine at 50% speed, the SPAN potentiometer should be adjusted for a 5.0V output.

3.3 DC TACHOMETER CALIBRATION *continued...*

If you are calibrating a Roll tachometer and there is some material on the core, measure the roll diameter and adjust the SPAN potentiometer to produce a test point voltage of:

10 x (core diameter / actual diameter) for max speed or

5 x (core diameter / actual diameter) for 50% speed

Once calibrated, decrease and increase the machine speed and verify the DC Tachometer input card output follows machine speed changes. Stop the machine and verify the output drops down to 0.0V. If the output does not read 0.0V with the machine stopped, adjust the ZERO offset potentiometer (RT701) to bring the output to 0.0V and repeat the calibration steps for max speed as described above.

If calibrating the Line speed input, the **Max Line Speed** setting in the *Setup Menu > Line Speed Setup* menu should be set to the line speed represented by 10V on the tachometer option card output. The **Line Speed Units** setting should be set to the desired line speed display units.

3.4 PULSE TACHOMETER CALIBRATION

Pulse tachometer line and roll speed signals are wired directly to the main terminal block (TB1). The positive and negative outputs of the line pulse tachometer signal should connect to terminal 15 (+PULSE LINE), and terminal 16 (-PULSE LINE) respectively. The positive and negative outputs of the roll pulse tachometer signal should connect to terminal 12 (+PULSE ROLL), and terminal 13 (-PULSE ROLL) respectively. Shield inputs, terminals 14 and 11, are provided for the line and roll input signals for noise reduction.

The pulse tachometer inputs accept a signal with a peak voltage that falls within 1 to 50V. While the peak output voltage of the tachometer is not important (as long as it is under 50V) the low voltage must come close to 0V for an accurate pulse reading.

Line Pulse Tachometer Calibration:

1. Ensure the pulse tachometer is properly wired to its respective terminal and power is applied to the EasyWeb™ controller.
2. Navigate to *CALIBRATION MENU>CAL LINE PTACH* and press enter/menu key. The calibration screen prompts you to enter the percentage of maximum line speed you will be calibrating at. This percentage must match the machine calibration speed, which is typically 100% max speed or 50% max speed. For example, if you are calibrating your machine at max speed, set the calibration speed percentage to 100%, if you are calibrating your line speed at 50% speed, set the calibration speed percentage to 50%.
3. Run the machine at the speed corresponding to the calibration speed percentage selected in the previous step. Use a hand tachometer to verify the machine is running at the correct line speed and press the enter/menu button to calibrate. If calibration was successful, a “CALIBRATION COMPLETE” message will appear. If calibration was unsuccessful a “Error! Cant Calibrate” message will appear. This usually indicates the controller is not reading any pulses. Refer to section 7 for trouble shooting.
4. If calibration was successful, navigate to the *DIAGNOSTICS MENU>LINE INPUT* screen and verify the line speed reading is correct. Decrease and increase the machine speed and verify the line speed reading follows the line speed changes. Stop the machine and verify the line speed drops to zero.

Roll Pulse Tachometer Calibration:

1. Ensure the pulse tachometer is properly wired to its respective terminal and power is applied to the EasyWeb™ controller.
2. Navigate to *CALIBRATION MENU>CAL ROLL PTACH* and press enter/menu key. The calibration screen asks if you are calibrating the roll speed with an empty core, if so select “YES”, if there is some material on the core select “NO”. If you selected “NO”, measure the current roll diameter and enter it at the prompt. The calibration screen then prompts you to enter the percentage of maximum line speed you will be calibrating at. This percentage must match the machine calibration speed, which is typically 100% max speed or 50% max speed. For example, if you are calibrating your machine at max speed, set the calibration speed percentage to 100%, if you are calibrating your machine at 50% speed, set the calibration speed percentage to 50%.

3.4 PULSE TACHOMETER CALIBRATION *continued...*

3. Run the machine at the speed corresponding to the calibration speed percentage selected in the previous step. Use a hand tachometer to verify the machine is running at the correct line speed and press the enter/menu button to calibrate. If calibration was unsuccessful an “Error” message will appear. This usually indicates the controller is not reading any pulses. Refer to section 7 for trouble shooting.
4. Navigate to the *DIAGNOSTICS MENU>ROLL INPUT* screen, this screen displays the roll speed percentage with 100% representing the roll speed at core. Also displayed is the pulses-per-second(pps) reading coming from the pulse tachometer-this is used to verify that pulses are being read by the controller. If you calibrated the roll speed with an empty core the roll speed percentage will match the line speed percentage. If you calibrated with some material on the core, the roll speed percentage will be, $\text{roll_speed_percentage} = \text{line_speed_percentage} \times (\text{core diameter} / \text{measured diameter})$. For example, if there was a 24in diameter roll with a 4in core and you calibrated at 50% max line speed, then the ROLL INPUT screen will display a percentage of $\text{roll_speed_percentage} = 50 \times (4\text{in} / 24\text{in}) = 8.3\%$

3.5 SIGNAL FILTERING

The diameter and line/roll inputs all feature adjustable input filtering. These are rolling average filters used to filter high frequency noise. Greater filter times allow for a cleaner signal with the drawback of added delay.

1 Diameter

The diameter filter action is determined by the **DiamFilter Time** parameter, located in the *CALIBRATION MENU > DiamFilter Time* screen. Increasing the filter time can help filter high frequency diameter noise, such as caused by an out of round roll. As the diameter signal is typically a very slow changing signal, this filter time can be set reasonably high without having a negative effect on control.

2. Line / Roll

The Line and Roll Inputs share a common filter time parameter named **LINE/ROLL FTIME**. Increasing the filter time for one will do the same for the other. This setting is located in the *CALIBRATION MENU>LINE/ROLL FTIME*. The only time the Roll Input is used is in conjunction with the Line Input for tachometer ratio diameter calculation, and so sharing a common filter ensures that both signals are equally filtered in such applications. It should be noted that when using tachometer ratio diameter calculation mode for diameter input, the diameter filter applies to the calculated diameter value. This means that there are essentially two separate filters involved in the diameter signal reading in such applications, the Line / Roll Filter and the Diameter Filter. Increasing the filter time helps reduce the impact of noise, but also increases the delay to a fast changing Line Signal. Some experimentation may be required in setting the filter time to find optimal controller performance.

Your EasyWeb™ controller has been properly configured at the factory. Use this section to verify the configuration or to reconfigure the controller if your application requirements change.

Note: Drives must be in **torque mode** for proper operation.

4.1 GENERAL SETUP

The following steps are provided to setup the EasyWeb™. The parameters listed in this section are located in the **SETUP MENU**.

***Note**, the EasyWeb's menu structure is context dependant, meaning it will only display parameters that are relevant to your current configuration.

1. Set the **TENSION ZONE** parameter to **UNWIND** or **REWIND** depending on what tension zone the controller is used on.
2. Select the **DIAMETER INPUT** type, either **DIRECT** or **TACH RATIO CALC**. Direct type is used for diameter sensors such as range finders, and tach ratio calc is selected when using line and roll speed signals to calculate diameter.
3. Set the **DIAMETER UNITS**.
4. Set the **LineSpeed Units**.
5. The **LineSignalSource** parameter allows the user to select the type of tachometer used to determine line speed. If using a pulse tachometer set this parameter to **PULSE TACH**. If using a DC tachometer, set this parameter to **DC TACH**. Skip this step If not using a line speed signal.
6. The **RollSignalSource** parameter allows the user to select the type of tachometer used to determine roll speed. If using a pulse tachometer set this parameter to **PULSE TACH**. If using a DC tachometer, set this parameter to **DC TACH**. Skip this step If not using a roll speed signal.
7. Set the **MAX LINE SPEED**. This setting allows you to specify the maximum line speed you will be running.
8. Set the **THRESHOLD SPEED**. This parameter is only available if the **DIAMETER INPUT** type is **TACH RATIO CALC**. Otherwise it is hidden from the user. The threshold speed allows the user to set the minimum line speed the controller uses for diameter calculation. Beneath this speed the diameter will be frozen at the last calculated value. This parameter is usually set to from 5-10% maximum line speed.
9. Set **INERTIA COMP** value. This value is determined through experimentation and is used to match the acceleration rate of the winder to the acceleration rate of the line. To set this parameter, load material onto the line and accelerate the line. Slackening of the web indicates too little compensation, while tightening indicates too much. Adjust the **INERTIA COMP** value until the web tension remains constant while accelerating line speed. Inertia compensation is optional and is useful only when accelerating line speeds at a high rate, for slower acceleration rates **INERTIA COMP** is usually unnecessary. 0 indicates no inertia compensation, while 100 indicates maximum inertia compensation.
10. Set the **MINIMUM OUTPUT** value. This setting has two different functions depending on the torque device used.

Brake or Clutch:

For brake/clutch systems, sometimes the controllers output drops to a level that causes the brake to free-wheel. This occurs when the roll is reaching core. For this situation the **MINIMUM OUTPUT** value supplies extra output to prevent the web from losing tension. The amount of extra output provided is set as a percentage of maximum output(10V or 16mA) and limited to 25%. To determine if a **MINIMUM OUTPUT** setting is needed, run a roll from max diameter to core and see if the web begins to slack as the roll reaches core. If so, increase the **MINIMUM OUTPUT** setting and repeat the process until the brake/clutch maintains tension throughout the roll.

4.1 GENERAL SETUP *continued...*

Drive:

For driven systems, the **MINIMUM OUTPUT** sets the minimum torque level required to overcome the static friction of the system at core. To set this value, put the controller in manual mode with no material on the core and increase the manual output as high as possible without having the winder begin to rotate. With this setting, the addition of only a slight amount of torque will start the winder rotating. Note the output percentage and enter it in the **MINIMUM OUTPUT** setting.

11. Set **SWITCHED SS** On or Off. See section 4.2, Soft Start Setup for more information.
12. Set **SPEED SS** On or Off. See section 4.2, Soft Start Setup for more information.
13. Set the **SS OUTPUT LEVEL**. This parameter is only available if **SWITCHED SS** or **SPEED SS** are on. The **SS OUTPUT LEVEL** setting determines the controllers output when soft start is engaged. This is set as a percentage of maximum output. See section 4.2, Soft Start Setup for more information.
14. Set the **SPEED SS TRIP** value. If **SPEED SS** is on, the controller will enter soft start mode when the line speed drops below the **SPEED SS TRIP** value. If **SPEED SS** is off, this parameter will be hidden. See section 4.2, Soft Start Setup for more information.
15. Set the **SS DELAY** time. This parameter is only shown if **SPEED SS** is on. See section 4.2, Soft Start Setup for more information.
16. Set **OutptOffByESTOP** YES or NO. This setting allows the user to specify whether the output will remain on during an emergency stop condition (to pick up control after the emergency stop condition is removed) or whether it will be forced off (forcing the operator to re-engage the output after an emergency stop condition).
17. The **ZERO ANLG INPUTS** screen allows the user to zero any offsets in the analog signal inputs (Diameter In, Roll In, and Line In). This is done in the factory and should not have to be repeated unless the controller is reset, clearing all memory. Zeroing the analog offsets will clear any small offset signal that is displayed in the *Diagnostic Menu for line, roll, and diameter displays* when nothing is connected to the inputs. The **ZERO ANLG INPUTS** function is designed to account for any small offsets caused by the analog circuitry in the controller, NOT to account for offsets in external components. For this reason, all signal input connections must be removed before running the **ZERO ANLG INPUTS** function, even if the input is reading 0V, there could be a small offset that will add inaccuracy if not removed.
18. The **RESET DEVICE** function can be used to completely clear the Controller's memory, returning it to a default state. This action should never be performed unless instructed to do so by DFE Technical Support. Resetting the controller will clear all saved settings as well as the calibration values and the factory adjusted analog offset values.

4.2 SOFT START SETUP

Soft Start is normally used only in braked Unwind zone applications, and should be left Off when the controller is being used to control Rewind tension. Soft Start is used to reduce the control output to a preset (user adjustable) low level to prevent brake lockup when the machine starts. Upon exiting Soft Start, the controller resumes automatic control mode. When Soft Start is active, the home screen will alternate between a "SS ON" message and the soft start output level. Soft Start is only available when the controller is in Auto mode (not in Manual mode).

Soft Start can be actuated by any of two methods:

1. Automatically by machine speed dropping below the speed trip point (after an adjustable delay).
2. Immediately upon closure of an external contact.

It is possible to actuate Soft Start using one or more sources at a time.

4.2 SOFT START SETUP *continued...*

1. Actuation by Line Speed

Soft Start by Line Speed requires a valid Line Speed input signal (see Section 3.1 Line/Roll Speed Input Calibration). To activate, navigate to the *SETUP MENU > SWITCHED SS* screen and set the **SWITCHED SS** setting to **on**. Within the same menu, set the **SS SPEED TRIP** setting to the desired Line Speed trip point. For example, with a max line speed of 1,000 ft/min and a **SS SPEED TRIP** setting of 100 ft/min, Speed Soft Start will be activated when Line Speed falls below 100 ft/min. Typically, this value should be set to around 10% of your maximum Line Speed. The **SS DELAY** setting determines the length of time to delay after the Line Speed falls below the **SS SPEED TRIP** setting and before Soft Start is activated. This eliminates nuisance actuation if the Line Speed drops for only a short time. This delay is only associated with entering Soft Start mode, not leaving it. Line Speed Soft Start mode is exited immediately upon Line Speed climbing above the Speed Trip Point value. Finally, set the **SS Output Level** to the desired percentage of max output. It is best to set this value low, but high enough to produce enough tension to produce a smooth takeoff. The **SS Output Level** setting is used by both Soft Start modes.

2. Actuation by External Contact Closure

To activate, navigate to the *SETUP MENU > SWITCHED SS* menu and set the **Switched SS** setting to **On**. Connect an external switch or relay contact to the main terminal block (TB1) terminal 19 (SOFT START) and terminal 18 (GROUND) (see Section 2.9, Standard Electrical Connections). The controller will enter Soft Start mode immediately upon closure of the switch and will remain in Soft Start mode as long as the contact is closed. Finally, set the **SS Output Level** to the desired percentage of max output. The **SS Output Level** setting is used by both Soft Start modes.

4.3 ANTI-TAMPER/SECURITY LOCKOUT

The Anti-Tamper jumper can be used to limit operator access to certain menu functions and settings. When the Anti-Tamper function is enabled, only the settings within the *Operator Menu* are adjustable from the front panel. All other menu's are hidden from the user. Please contact DFE technical support for more information.

5.1 BASIC OPERATION

When the EasyWeb™ has been properly set up and calibrated, it should maintain constant web tension throughout the roll regardless of roll diameter or line speed changes. The EasyWeb™ maintains constant tension by varying the brake, clutch or motor torque with the change in roll diameter according to the following equation:

$$Tension = \frac{Torque}{Diameter}$$

Note: Drives must be in **torque mode** for proper operation

Therefore, in order to maintain constant tension the controller must apply a correction based on roll diameter and proportionally increase the output (Torque) as a wind roll builds up, or decrease the output (Torque) as an unwind roll becomes smaller.

In auto mode, the EasyWeb™'s setpoint determines the amount of output to be applied to the brake, clutch or drive at maximum roll diameter (See Figure 18). For example, if the setpoint is adjusted to 50, then the output will be $.50 \times 10V = 5V$ when the roll is at its maximum diameter. The setpoint value can be changed during actual operating by using the knob to increase or decrease the auto setpoint to fine tune the tension. As shown in Figure 18, the output level does not decrease to zero since the roll only decreases to core diameter; thus, there is a positive output level applied at the core diameter allowing constant tension control from maximum roll diameter down to core.

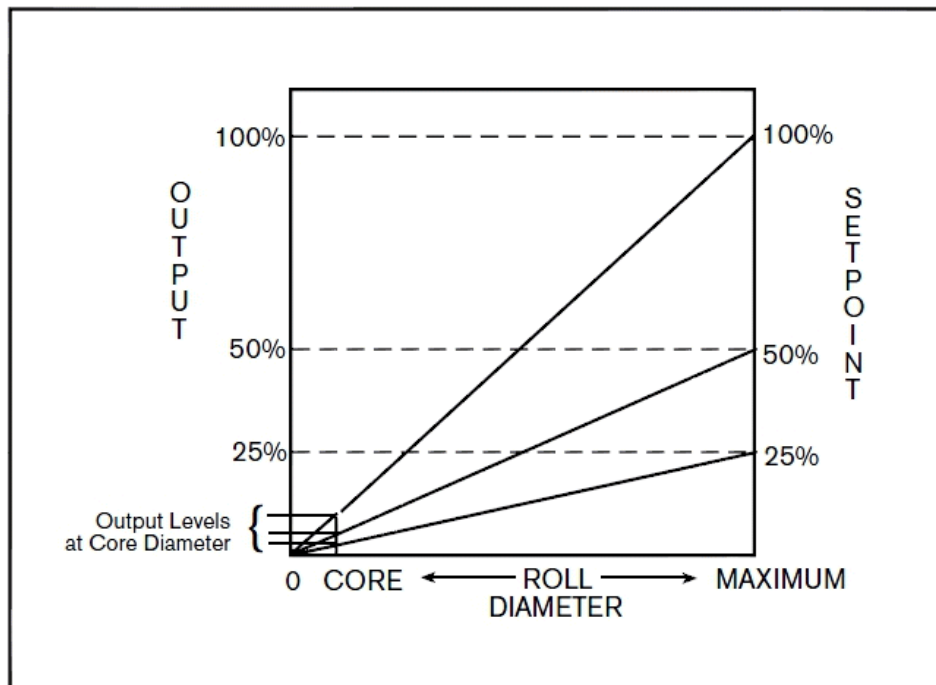

Figure 18 - CONTROLLER OUTPUT VS. DIAMETER

When the EasyWeb™ is in manual mode, the controllers output is manually controlled by increasing or decreasing the manual setpoint. The display indicates 0 to 100% output.

5.2 OPERATING MODES AND USER INTERFACE

The operating modes and user interface are summarized below.

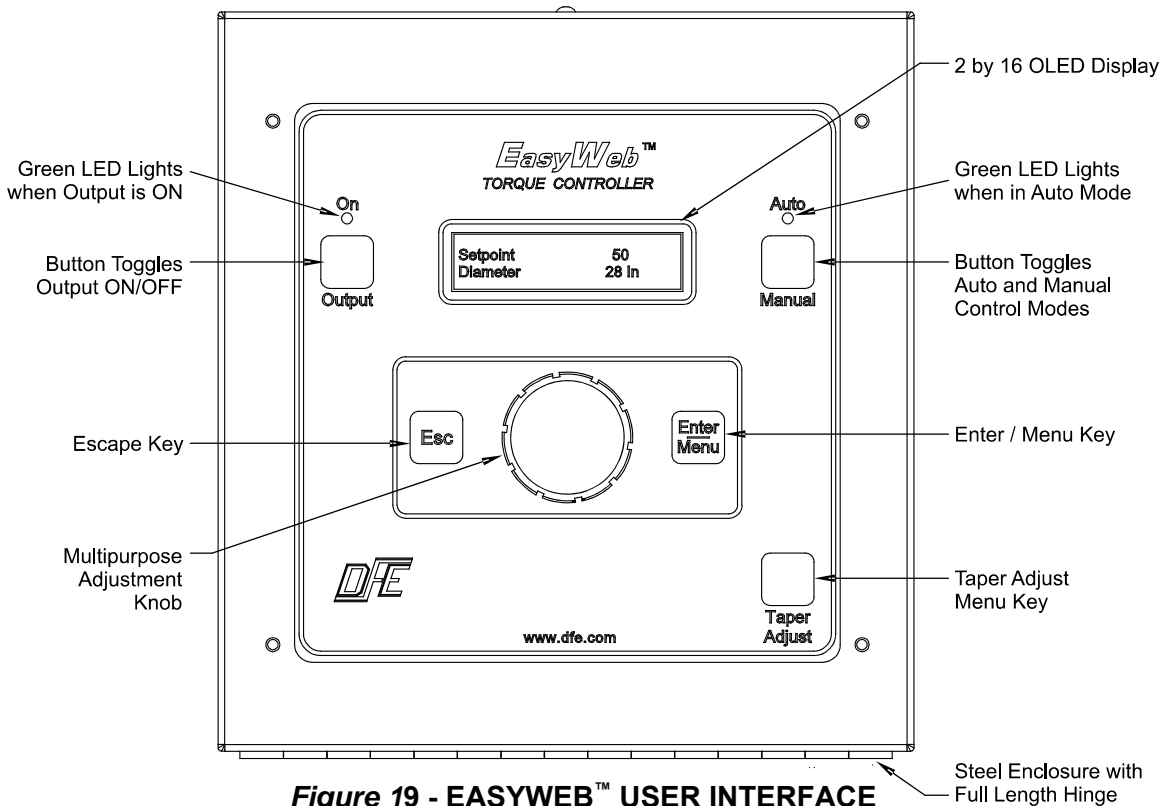

Figure 19 - EASYWEB™ USER INTERFACE

Auto: The controller automatically maintains constant tension by compensating the output with diameter. Tension can be increased or decreased by adjusting the setpoint. The auto LED is on in this mode.

Manual: Controller output is manually controlled by the adjustable output percentage. If switched to Auto, this value will ramp up to the calculated auto value. When in auto, if switched to manual, the output remains the same until its changed by adjusting the output percentage. The auto LED is off in this mode.

Output On: Output is active.

Output Off: Output is zero or 4mA.

Enter/Menu: Used to navigate through the user menu and enter settings.

Esc: Used to navigate back to the home screen and cancel parameter changes.

Taper Adjust: Used to adjust the taper percentage.

5.3 OPERATOR MENU

The Easyweb's operator menu contains all the settings an operator would need to run a rewind or unwind machine. The settings described in this section are located in the **OPERATOR MENU**.

1. The **AUTO SETPOINT** setting allows the user to view and adjust the auto setpoint while the controller is in manual mode.
2. The **MANUAL OUTPUT** setting allows the user to view and adjust the manual output while the controller is in auto mode.
3. The **SET CORE DIAM** allows the user to enter the core diameter used.
4. The **SET MAX DIAM** setting allows the user to enter the maximum roll diameter used.
5. The **TAPER ENABLE** setting allows the user to turn the taper tension function on or off. This setting is only shown if the **TENSION ZONE** is set to rewind. See section 5.4 Using Taper Tension, for more information.

5.3 OPERATOR MENU *continued...*

6. The **DiamAlarmEnable** setting allows the user to enable or disable the diameter alarm function. The diameter alarm output (terminal 23) is an open collector contact that provides a path to ground when the alarm is triggered. Refer to Section 2.9, Standard Electrical Connections for connection diagrams.
7. The **MIN DIAM ALARM** setting is used to set the alarms minimum diameter threshold. This is used on unwind applications to trigger the alarm output when the diameter falls below the specified diameter.
8. The **MAX DIAM ALARM** setting is used to set the alarms maximum diameter threshold. This is used on rewind applications to trigger the alarm output when the diameter increases above the specified diameter.
9. The **DISPLAY MODE** setting allows the user to choose what signals appear on the home screen.
10. The **SWITCH FUNCTION** setting allows the user to choose how the output and auto modes behave when an external switch is shorted to ground (terminal 24 shorted to terminal 25) The user can select between toggling both output and auto on or off, toggle the output only, or toggle auto mode only.

5.4 USING TAPER TENSION

Taper causes the Auto setpoint to automatically decrease as the diameter increases. This helps to produce a better quality roll by eliminating telescoping, crushed cores and too tight or too loose rolls.

Taper is controlled with the **TAPER ENABLE** and **TAPER PERCENT** settings. The taper percentage setting is accessed by pressing the taper adjust button on the front panel. The **Taper Enable** setting allows for toggling the Taper function On and Off. Even though a controller may be set up for Taper, a particular job may not require it, and so this setting allows the user to turn it off while allowing its use for a later time. The **Taper Percentage** setting controls the amount of effect the Taper function has when enabled. The Taper function causes a setpoint multiplier to change from unity at core to a multiplier value of 100% minus the taper setting at full roll.

For example: With a setpoint of 50, and a **Taper Percentage** setting of 20%, the Auto setpoint will be 50 at core, decreasing linearly to $(100\% - 20\%) \times 50 = 40$ at full roll—effectively reducing the tension by 20% from core to full roll.

Finding the right Taper configuration settings for a particular process may take some experimentation in adjusting both the auto setpoint and the **Taper Percentage**. See the table below for common winding defects and the corresponding corrective action.

Location	Tight/Loose	Example	Move
Core	Tight	Blocking, Crushed Core	Decrease Tension
Core	Loose	Telescope During Unwinding	Increase Tension
Outside	Tight	Baggy Lane Due to Gage Variation	Increase Taper
Outside	Loose	Out-of-Round Roll	Decrease Taper
Global	Tight	Telescope During Winding, Starring	Increase Tension and Taper

Roisum, David R. What is the Best Taper to Run on My Winder? *Converting Magazine*, ©November 2007.

5.5 RESETTING DIAMETER ALARM

When the diameter alarm is activated by either minimum or maximum diameter condition, the screen will display an alternating “DiamAlarm Active” and “PressEscToReset” message to inform the operator the diameter alarm has been triggered. The alarm can only be turned off by pressing the Esc button, otherwise it will persist even after the diameter has returned into a valid range. If the diameter alarm is cleared while the diameter is still above or below the threshold, it will not trigger again until the diameter has returned to within a valid range and crosses the threshold again. Refer to Section 2.9, Standard Electrical Connections for diameter alarm connection diagrams.

SECTION 6

CARE AND MAINTENANCE

It is not necessary to perform any type of maintenance on the controller. However, you may find it worthwhile to observe whether there is a buildup of dust, debris, or moisture on or near the unit after a period of time. If so, you may consider moving the unit or putting the unit in an enclosure more suited to your particular environment.

Washing the exterior of the unit may be done using warm water and a mild detergent on a cloth. Disconnect power prior to cleaning. Do not spray or pressure wash unit. Ensure unit is dry prior to reconnecting power.

Most problems are caused by incorrect installation or misapplication of the equipment, so it is important to read through the manual and follow the proper installation, calibration and configuration procedure.

If you would like assistance evaluating your installation, please call Technical Service at Phone: (603) 332-6150 Fax:(603) 332-3758 Email: techsupport@dfc.com. We offer experienced technicians whose responsibility it is to make sure you are satisfied with your DFE equipment.

For controllers with a pneumatic output, check the following factors:

1. The output pressure should not fall below 5 psi at core diameter. If it does, the controller may be unstable. This is caused by the compressibility of air, which creates a time delay when the controller calls for a change of output pressure. At low pressures the delay becomes long.
2. The air connection between the controller and the brake or clutch should be 1/4 inch O.D. tubing, no longer than 25 feet long. Larger or longer tubing creates excessive volume which causes a time delay when output pressure changes. This can cause instability. If greater distance is unavoidable, the pneumatic enclosure should be moved closer to the brake or clutch. Use of a volume booster is an alternative. Call Technical Service at (603) 332-6150 for details.

7.1 DIAGNOSTIC MENU

The EasyWeb™ 's Diagnostic menu provides displays for the diameter, line speed, roll speed, and customer power supply signals. The display inputs/outputs described below are all located in the **DIAGNOSTICS MENU**.

1. The **DIAMETER INPUT** display shows the voltage present on the main terminal block's diameter input (terminal 7&6)
2. The **LINE INPUT** display shows the line speed signal in ft/min or m/min. This signal comes from either the main terminal block's +Line pulse input (terminal 15&16) if using a pulse tachometer, or the DC tachometer card if using a DC tachometer.
3. The **ROLL INPUT** display shows the roll speed signal. If using a DC tachometer card, the signal will be in volts. If using a pulse tachometer, the display will show the roll speed percentage with 100% representing the roll speed at core. Also shown is a pulse-per-second reading, this is to verify pulses are being read by the controller.
4. The **+10/15V SUPPLY** display shows the voltage present at the main terminal block's +10/15 output (terminal 5&6). This voltage will be +10V or +15V depending on the location of the JP6 jumper.

SECTION 8

REPLACEMENT PARTS LIST

WARNING: When replacing fuses, use only fuses with ratings as shown below. Failure to do this may compromise personal safety and may create a fire hazard!

Main Circuit Board

Control Board 723-2902

Optional Power Supply

AC to DC Power Supply 144-0026

AC Power Supply Option Assembly 723-2907

Optional Circuit Cards

DC Tachometer Option Card Assembly 723-2085

Pneumatic Version

Pneumatics Module 723-2037

Air Filter 119-0024

Servo Valve 621-2586

V-Out Version

V-Out Module 723-2817

SCR Bridge 103-0013

Low Voltage Fuses 115VAC (125mA 250V Slow) 108-0086

Low Voltage Fuses 230VAC (63mA 250V Slow) 108-0094

Output Fuses (5A 250V Fast) 108-0003

Controller to Pneumatic/V-Out Cables

20' Cable 721-2836

"L" Cable 721-2837

Manuals

Technical Reference Manual 801-2447

Quick Start Guide 801-2456

Appendix A: Locations of Jumpers and Adjustments

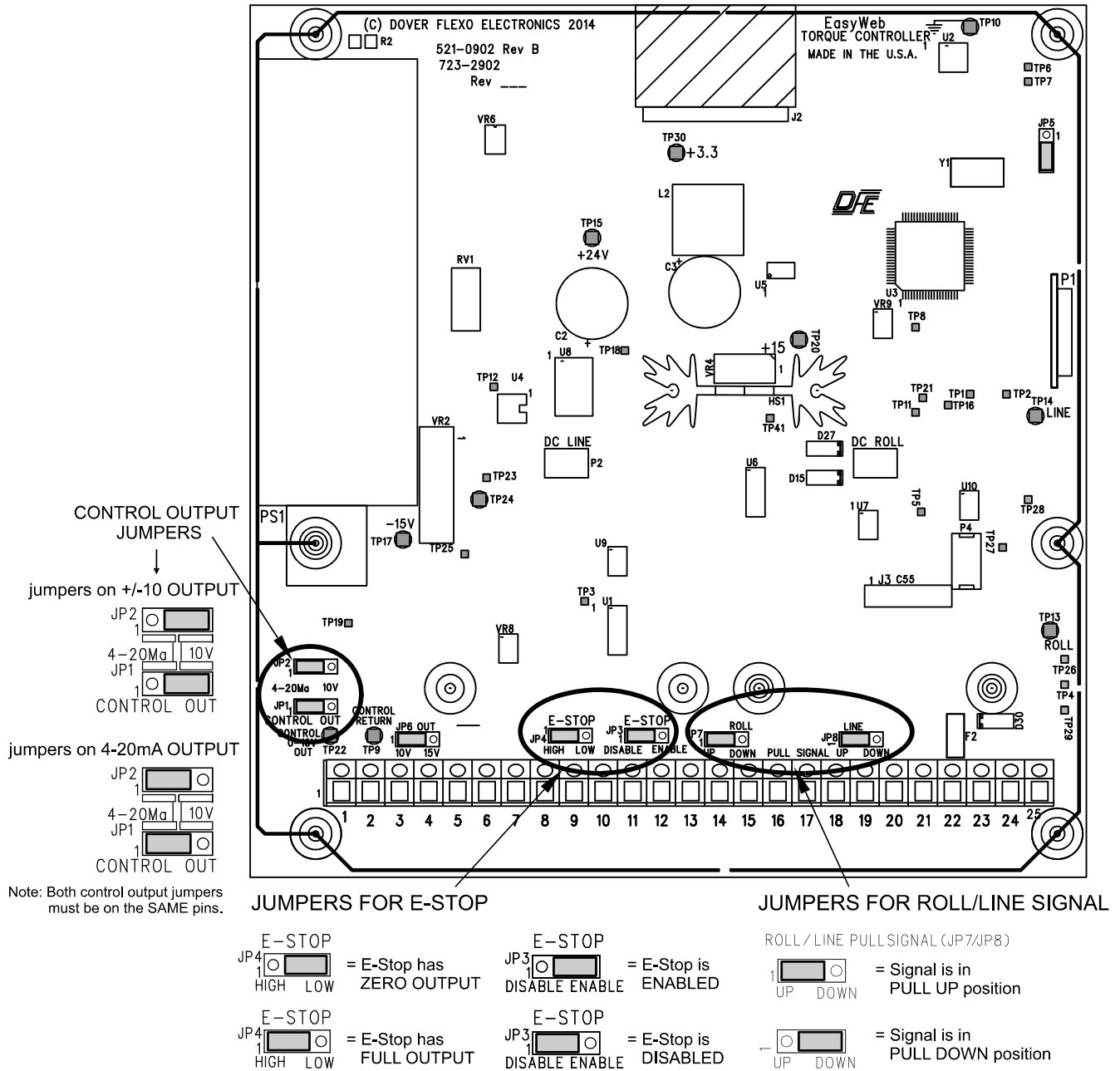

Figure 20 - CONTROL BOARD SHOWING JUMPER LOCATIONS

Menu System Hierarchy

*Note: Dark Gray Screens are not shown for certain configurations.

Auto mode Manual mode
 Setpoint XXX.X Output XX.X
 Diam XXX.XIN Diam XXX.XIN

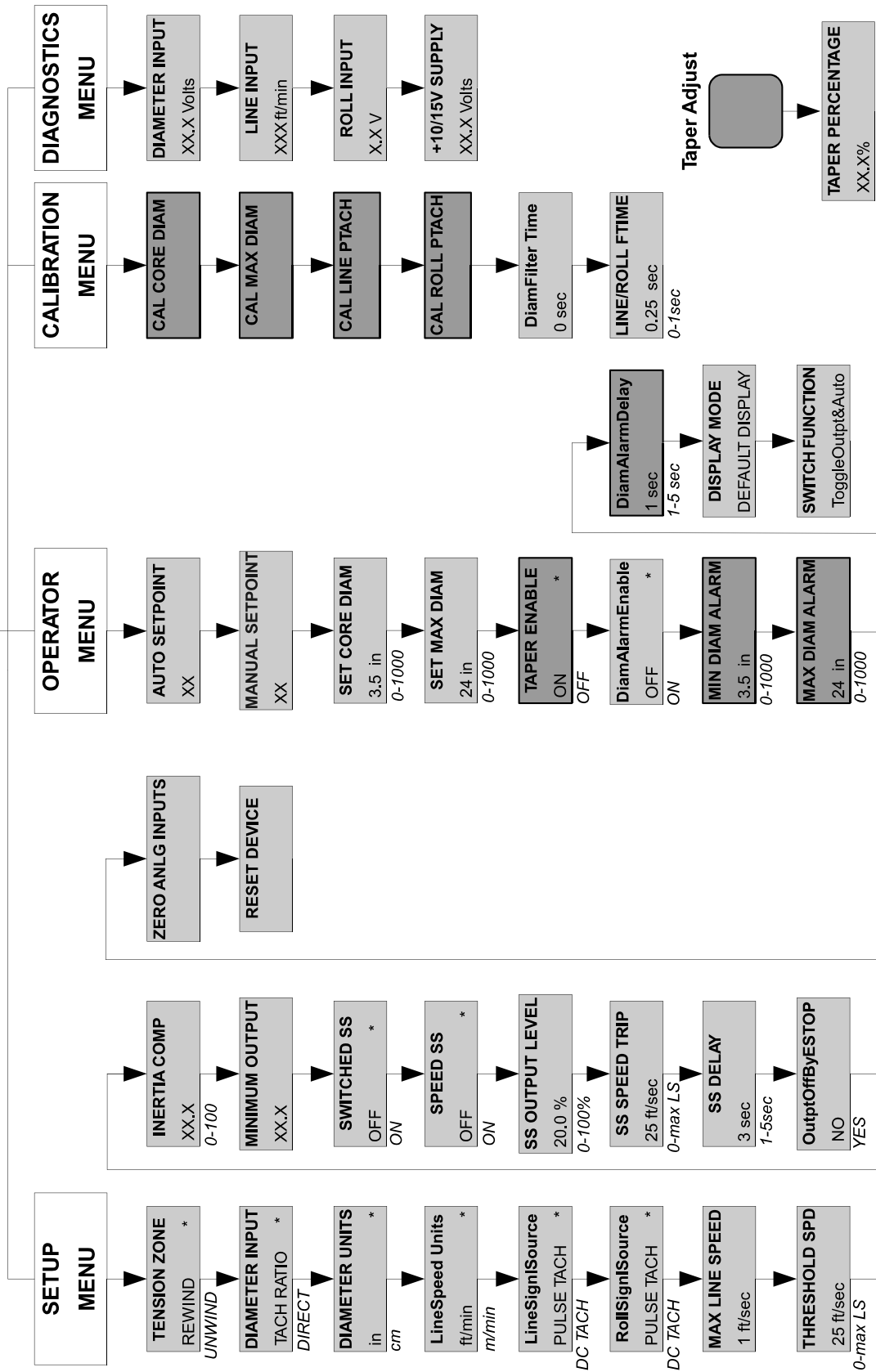

Figure 21 - MENU HIERARCHY

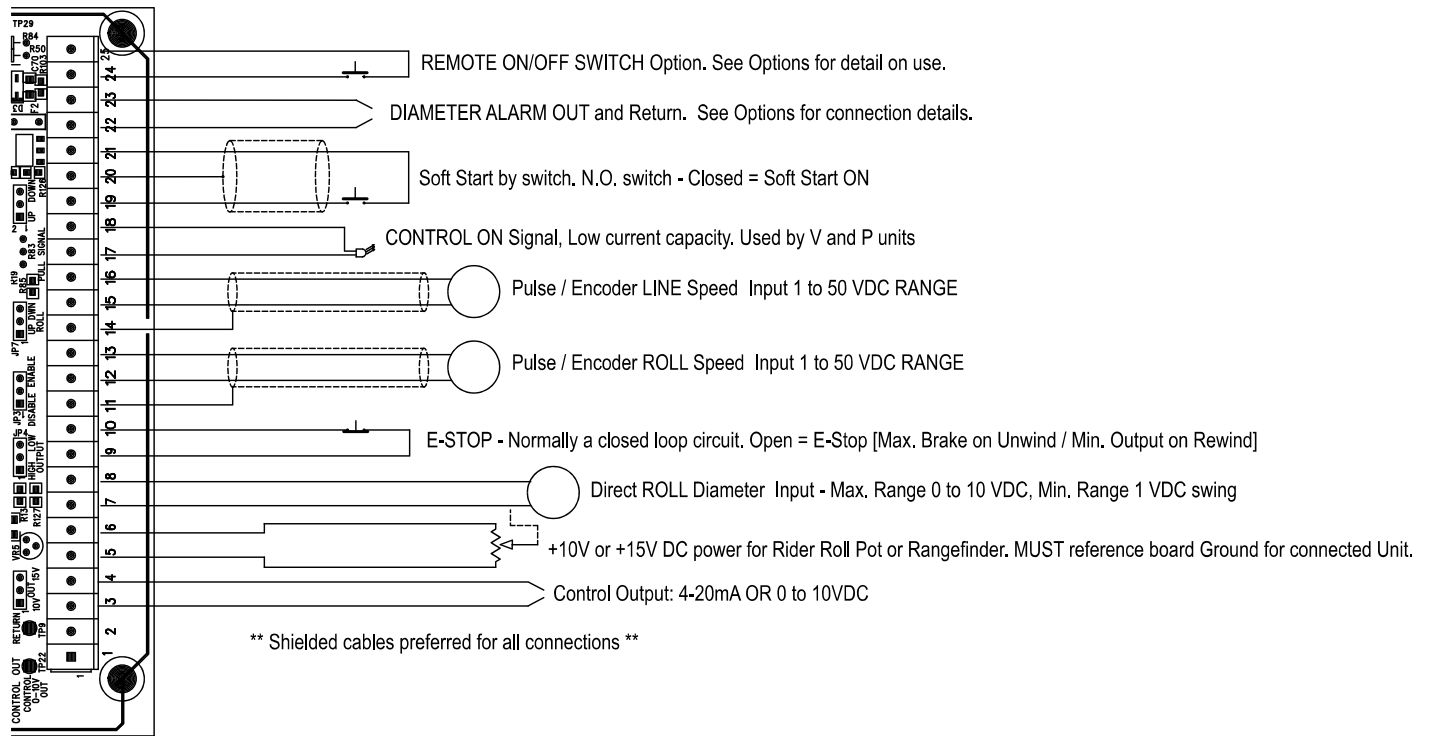

Figure 22 - STANDARD AND 0-10VDC CONTROL BOARD ELECTRICAL CONNECTIONS

OVERVOLTAGE CATEGORY: Classification of parts of installation systems or circuits with standardized limits for transient overvoltages, dependent on the normal line voltage to earth.

POLLUTION: Any addition of foreign matter, solid, liquid or gaseous (ionized gases), that may produce a reduction of dielectric strength or surface resistivity.

POLLUTION DEGREE 2: Normally only non-conductive POLLUTION occurs. Occasionally, however, a temporary conductivity caused by condensation must be expected.

1. THE COMPANY

Dover Flexo Electronics, Inc. is hereinafter referred to as the Company.

2. CONFLICTING OR MODIFYING TERMS

No modification of, additions to or conflicting provisions to these terms and conditions of sale and shipment, whether oral or written, incorporated into Buyer's order or other communications are binding upon the Company unless specifically agreed to by the Company in writing and signed by an officer of the Company. Failure of the Company to object to such additions, conflicts or modifications shall not be construed as a waiver of these terms and conditions nor an acceptance of any such provisions.

3. GOVERNING LAW

This contract shall be governed by and construed according to the laws of the state of New Hampshire, U.S.A. The parties agree that any and all legal proceedings pursuant to this contract shall take place under the jurisdiction of the courts of the State of New Hampshire in the judicial district of Strafford County.

4. PENALTY CLAUSES

Penalty clauses of any kind contained in orders, agreements or any other type of communication are not binding on the Company unless agreed to by an officer of the Company in writing.

5. WARRANTY

Dover Flexo Electronics, Inc. warrants, to the original Buyer, its' products to be free of defects in material and workmanship for five years from date of original shipment. Repairs on products are warranted for 90 days from date of shipment. During the warranty period the Company will repair or replace defective products free of charge if such products are returned with all shipping charges prepaid and if, upon examination, the product is shown to be defective. This warranty shall not apply to products damaged by abuse, neglect, accident, modification, alteration or mis-use. Normal wear is not warranted. All repairs and replacements under the provisions of this warranty shall be made at Dover Flexo Electronics or at an authorized repair facility. The Company shall not be liable for expenses incurred to repair or replace defective products at any other location or by unauthorized persons or agents. This warranty contains all of the obligations and warranties of the Company. There are no other warranties, either expressed or implied. No warranty is given regarding merchantability or suitability for any particular purpose. The Company shall not be liable in either equity or law for consequential damages, losses or expenses incurred by use of or inability to use its' products or for claims arising from same. No warranty is given for products of other manufacturers even though the Company may provide these products with its' own or by themselves. The provisions of this warranty can not be changed in any way by any agent or employee of the Company. Notice of defects must be received within the warranty period or the warranty is void. The warranty is void if the serial number tag is missing or not readable.

6. PAYMENTS

Standard terms of credit are net 30 days from date of shipment, providing satisfactory credit is established with the Company. Amounts past due are subject to a service charge of 1.5% per month or portion thereof or 18% per annum. The Company reserves the right to submit any unpaid late invoices to a third party for collection and Buyer shall pay all reasonable costs of such collection in addition to the invoice amount. All quoted prices and payments shall be in U.S. Dollars.

If the Company judges that the financial condition or payment practices of the Buyer does not justify shipment under the standard terms or the terms originally specified, the Company may require full or partial payment in advance or upon delivery. The Company reserves the right to make collection on any terms approved in writing by the Company's Finance Department. Each shipment shall be considered a separate and independent transaction and payment therefore shall be made accordingly. If the work covered by the purchase order is delayed by the Buyer, upon demand by Company payments shall be made on the purchase price based upon percentage of completion.

7. TAXES

Any tax, duty, custom, fee or any other charge of any nature whatsoever

imposed by any governmental authority on or measured by any transaction between the Company and the Buyer shall be paid by the Buyer in addition to the prices quoted or invoiced.

8. RETURNS

Written authorization must be obtained from the Company's factory before returning any material for which the original Buyer expects credit, exchange, or repairs under the Warranty. Returned material (except exchanges or repairs under the Warranty) shall be subject to a minimum restocking charge of 8%. Non-standard material or other material provided specially to the Buyer's specification shall not be returnable for any reason. All material returned, for whatever reason, shall be sent with all freight charges prepaid by the Buyer.

9. SHIPPING METHOD AND CHARGES

All prices quoted are EXW the Company's factory. The Company shall select the freight carrier, method and routing. Shipping charges are prepaid and added to the invoice of Buyers with approved credit, however the Company reserves the right to ship freight-collect if it prefers. Shipping charges will include a charge for packaging. Company will pay standard ground freight charges for items being returned to Buyer which are repaired or replaced under the Warranty. Claims of items missing from a shipment must be received, in writing, within 30 days of original shipment

10. CANCELLATION, CHANGES, RESCHEDULING

Buyer shall reimburse Company for costs incurred for any item on order with the Company which is cancelled by the Buyer. Costs shall be determined by common and accepted accounting practices.

A one-time hold on any item ordered from the Company shall be allowed for a maximum of 30 days. After 30 days, or upon notice of a second hold, Company shall have the right to cancel the order and issue the appropriate cancellation charges which shall be paid by Buyer. Items held for the Buyer shall be at the risk and expense of the Buyer unless otherwise agreed upon in writing. Company reserves the right to dispose of cancelled material as it sees fit without any obligation to Buyer.

If Buyer makes, or causes to make, any change to an order the Company reserves the right to change the price accordingly.

11. PRICES

Prices published in price lists, catalogs or elsewhere are subject to change without notice and without obligation. Written quoted prices are valid for thirty days only.

12. EXPORT SHIPMENTS

Payment for shipments to countries other than the U.S.A. and Canada or to authorized distributors shall be secured by cash in advance or an irrevocable credit instrument approved by an officer of the Company. An additional charge will apply to any letter of credit. There will also be an extra charge for packaging and documentation.

13. CONDITION OF EQUIPMENT

Buyer shall keep products in good repair and shall be responsible for same until the full purchase price has been paid.

14. OWNERSHIP

Products sold are to remain the property of the Company until full payment of the purchase price is made.

terms.9 1/25/18

NOTES

INDEX

+10/15V Customer Output	5,12	Operating Instructions	25-27
0-10 Volt Control Output 2,3,4,11		Options	5
230 Volt Power (Option for V version)	2, 3, 5, 16	Output,	
100-240 Volt Power Input	3	0-10V	2, 12
4-20mA Output	2, 3	4-20mA	2, 3
		0-24 volt	2, 3, 16
AC Power Connections	3, 8, 12	0-45 volt	2, 3, 16
Accessories	5	Panel (Open)Mount	3, 6, 8, 10
Anti-Tamper Lockout	24	Pulse Tachometer	3, 4, 18, 20, 22, 29
Automatic Control Mode	4, 26	Pneumatics	2, 4, 5, 7, 8, 10, 30
		Power Input	3, 12, 31
Cables	5, 9, 30	Resetting Device	23
Calibration	17-21	Replacement Parts	30
line speed	18	Rewind Zone	1, 22
roll speed	18		
roll diameter	19	Safety Requirements	8-9
Care and Maintenance	28	Setup	22, 24
Circuit Boards, diagrams of	13, 15, 19, 31	Shielding	9
Control Board	13, 15, 31	Signal Filtering	21
Control Output	2, 3, 4, 5, 11	Soft Start	4, 23, 24
		Specifications	3, 4
DC Tachometer	3, 5, 14, 16, 18, 30	Standard Features	4, 5
Description	1	Tachometers,	
Diagnostic Menu	29	DC Tachometer	3, 5, 15, 18, 19
Diameter Input	4, 17, 20, 22, 29	Pulse Tachometer	3, 4, 18, 20, 22, 29
Dimensions	6-8	Taper Tension	4, 27
		Terms and Conditions	35
Electrical Connections	9, 12-16, 33	Tension Zones	1-2
Emergency Stop	5, 11-12	Troubleshooting	29
Enclosure	3, 6, 8, 9, 10	Unwind Zone	1-2, 22
Environmental Conditions	4	User Interface	26
Environmental Terms	34	Weights	4
		Warranty	35
Front Panel	1, 6, 26	Zero Analog Inputs	23
Fuses, replacement	30		
High Voltage Output	2, 3, 7, 8, 11, 16, 30		
Installation	8, 10-11		
Intermediate Zone	1-2		
Jumpers and adjustments	11, 12, 31		
Line Speed Calibration	18		
Manual Control Mode	4, 26		
Menu Hierarchy	32		
Mounting Location	3, 8		
Enclosure	8		
Open (panel)	8		
DC tachometer card	15		



307 PICKERING ROAD
ROCHESTER, NEW HAMPSHIRE 03867-4630 U.S.A
TEL: 603/332-6150
FAX: 603/332-3758
E-MAIL: info@dfec.com INTERNET: www.dfec.com

CANADA

MEXICO

UNITED KINGDOM

TAIWAN

KOREA

AUSTRALIA

COLOMBIA

SOUTH AFRICA