



INSTRUCTION MANUAL

Model UPBH Tension Transducers

DOC 801-0672 R2

5 YEAR WARRANTY



217 Pickering Road

Rochester, NH 03867-4630 U.S.A.

For assistance, please call:

TECHNICAL SERVICE - Installations, Start-Up, Troubleshooting, Repairs, Field Service, Returns. **techsupport@dfc.com**

CUSTOMER SERVICE - Replacement Parts, Individual Products, Questions about Orders, Manuals. **customerservice@dfc.com**

SALES - Product Information, Systems Application Questions, and placing orders for standard products and special systems.
sales@dfc.com

Telephone: (603) 332-6150 Fax: (603) 332-3758

E-mail: info@dfc.com Internet: www.dfc.com

TABLE OF CONTENTS

SECTION ONE: DESCRIPTION AND OPERATION	PAGE
1.1 General Description	1
1.2 Construction and Mechanical Operation	1
1.3 Electrical Operation	2
1.4 Specifications	3
1.5 Standard Features	3
1.6 Options	3
 SECTION TWO: INSTALLATION	
2.1 Dimensions	4
2.2 Pre-installation Requirements	5
2.3 Installing the Transducers	5
 SECTION THREE: CALIBRATION AND SETUP	
3.1 Introduction	8
3.2 Zero the Tension Meter	8
3.3 Calibrate the Tension Meter	8
 SECTION FOUR: CARE AND MAINTENANCE	
4.1 Removal of Roll and Pillow Blocks	9
4.2 Removing Transducers	9
4.3 Changing Electrical Connector Position	9
 SECTION FIVE: TROUBLESHOOTING GUIDE	10
 SECTION SIX: REPLACEMENT PARTS	12
 Appendices:	
A. Transducer Electrical Connections	13
B. Selection of Load Rating	14
C. Typical Tensions	15
 Terms and Conditions of Sale	16
Declaration of Conformity	17
Index	19

FIGURES

1. Cut-away View of Transducer	1
2. Strain Gage Connections	2
3. Dimensions	4
4. Tension Zones	5
5. Tension Force Direction	6
6. Bearing Mounting Bolt Length	7
7. Web Path	8
8. Model UPB Transducer Wiring	13

1.1 GENERAL DESCRIPTION

The Model UPBH Tension Transducer is an electro-mechanical device that converts web tension into a DC voltage which is proportional to tension. The voltage is amplified in external electronic circuitry and displayed on an analog or digital meter which is calibrated to indicate actual web tension, expressed in pounds, ounces, grams, kilograms, newtons or any other desirable units. It can also be supplied to a regulator circuit to control tension automatically.

The information in this Section will help give a clear understanding of the Model UPBH Transducer, how it works and how it is used.

1.2 CONSTRUCTION AND MECHANICAL OPERATION (see Figure 1)

In a typical installation, a transducer is mounted on each end of a standard idler roll. The roll shaft is secured to the transducer using a pillow block bearing or a shaft hanger, depending whether the shaft is rotating (live) or non-rotating (dead).

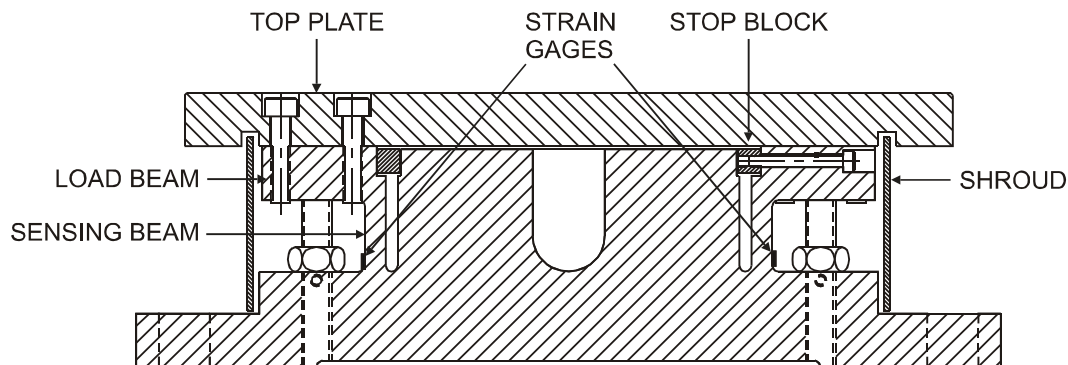

Figure 1 - CUT-AWAY VIEW OF MODEL UPBH TRANSDUCER

The UPBH Transducer can be installed in any position. But, when installed in the horizontal position, the idler roll weight does not affect the output thereby increasing the effective range of the transducer.

Inside the transducer is a dual cantilever beam with strain gages mounted on the outside surfaces. The top plate is attached to the load beams, and when moved in a parallel direction to the base, creates a deflection of the sensing beam. When tension is applied the sensing beam deflects a small amount, causing an electrical output from the strain gages.

A mechanical stop prevents damage from accidental overloads. The stop is functional in either horizontal direction, it also provides protection against excessive downward force. In either case, the beam is prevented from deflecting far enough to cause any damage.

1.3 ELECTRICAL OPERATION (see Figure 2)

The Model UPBH Transducer is used in pairs, one on each end of an idler roll shaft. Web tension exerts a force on the roll which is transmitted to the beam by the top plate. Two semiconductor strain gages are mounted on the beam, on the outside surfaces. As force is applied and the beam deflects, one gage is stretched and the other gage is compressed. This increases the electrical resistance of the stretched gage and decreases the resistance of the compressed gage. The gages in both transducers are electrically connected together in a Wheatstone bridge configuration. The bridge produces double the output of a single transducer and averages the outputs so web position, width and loose or tight edges do not affect the accuracy of the tension signal.

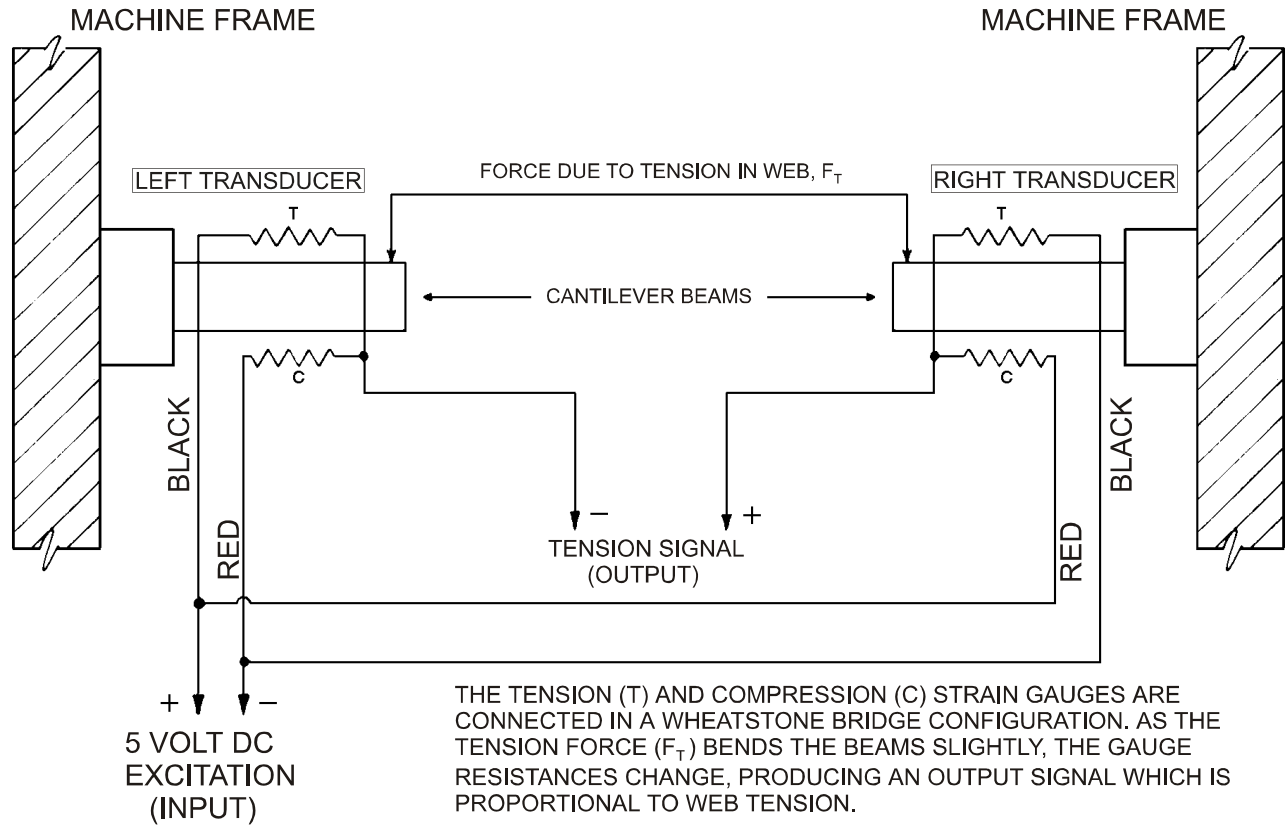

Figure 2 - STRAIN GAGE CONNECTIONS

The physical location of the strain gages, on opposite sides of the beam, ensures that each gage experiences the same temperature variations. This, and the Wheatstone bridge configuration, provides automatic temperature compensation and a stable output.

The strain gages are high output semiconductor devices which typically have an output sixteen times greater than the inexpensive foil gages used in some transducers. Therefore, the signal amplifier used with these Model UPBH transducers is a very stable low-gain design. An added benefit of the high output is inherent immunity to electrical noise.

1.4 SPECIFICATIONS

Electrical Specifications:

Excitation Voltage	5 Volts dc (10V with XR option)
Full Scale Output	250 mVdc nominal (500mVdc with XR)
Strain Gage Resistance	100 ohms nominal (200 ohms, XR)
Non-Repeatability	± 1/4% full span (FS)
Non-Linearity and Hysteresis Combined	± 1/2% FS
Temperature Range	-10°F to +200°F (-23°C to +93°C)
Temperature Coefficient	0.02% per deg. F typical, 0.01% per deg. C typical
Electrical Connections	pin A....white wire..output pin B....black wire..... +5V pin C....red wire..... - 5V
Mating Electrical Connector	Amphenol MS3106A-10SL-3S

Mechanical Specifications:

Materials	303/304 stainless steel and aluminum
Top Plate Displacement	0.010" (0.25 mm)
Load Ratings: Size 2	100, 200, 400, 800, 1200 lbs. (450, 900, 1800, 3600, 5350 N)
Size 3	1000, 2500, 5000 lbs. (4450, 11,125, 22,250 N)
Static Overload Capacity		
Size 2	2000 lbs. (8900 N)
Size 3	8000 lbs. (35,584 N)
Load Direction	parallel to top plate
Weight Size 2:	7 lbs. (3 Kg)
Size 3:	42 lbs. (19 Kg.)

1.5 STANDARD FEATURES

- Stainless Steel and Aluminum construction. Excellent corrosion resistance.
- Load Ratings to 5000 lbs.
- Zero maintenance design - no lubricated parts

1.6 OPTIONS

- **Drilled and Tapped top plate (DT).** Top plate drilled and tapped for bearing.
- **Environmental Connector (EC)** - Seals with mating cable environmental connector to protect against electrical contact oxidation; especially useful in corrosive environments.
- **Extended Range output (XR)** - Produces twice the output signal for a given load rating. Must be used with electronics having extended range option. Size 3 only.
- **Full Bridge (FB)** - Four strain gages in each transducer instead of two. Wheatstone bridge configuration. Used only when a single UPBH is used.
- **Permanently Attached Cable (PT).** Permanently attached cable instead of amphenol connector.
- **Permanently Attached Cable with connector (PTC).**
- **Right Angle Connector (RAB).** Allows electrical connector to plug in at 90° angle.

2.1 DIMENSIONS

SIZE		A	B	C	D	E	F	G	H	J	K	L	M	N	O	P	R	S	T	U	V	W
2	in	2.62	9.00	2.88	2.62	4.50	0.56	3.12	8.0	3.59	8.0	---	0.53	1.50	1.62	4.50	1.31	0.56	6.0	1.0	0.75	0.38
	mm	67	229	73	67	114	14	79	203	91	203	---	14	38	41	114	33	14	152	25	19	10
3	in	4.50	13.50	4.61	4.12	6.75	0.94	4.92	12.25	5.51	11.0	2.75	0.53	2.15	2.60	7.37	---	0.94	9.60	0.70	1.13	0.56
	mm	114	343	117	105	171	24	125	311	140	279	70	14	55	66	187	---	24	244	18	29	14

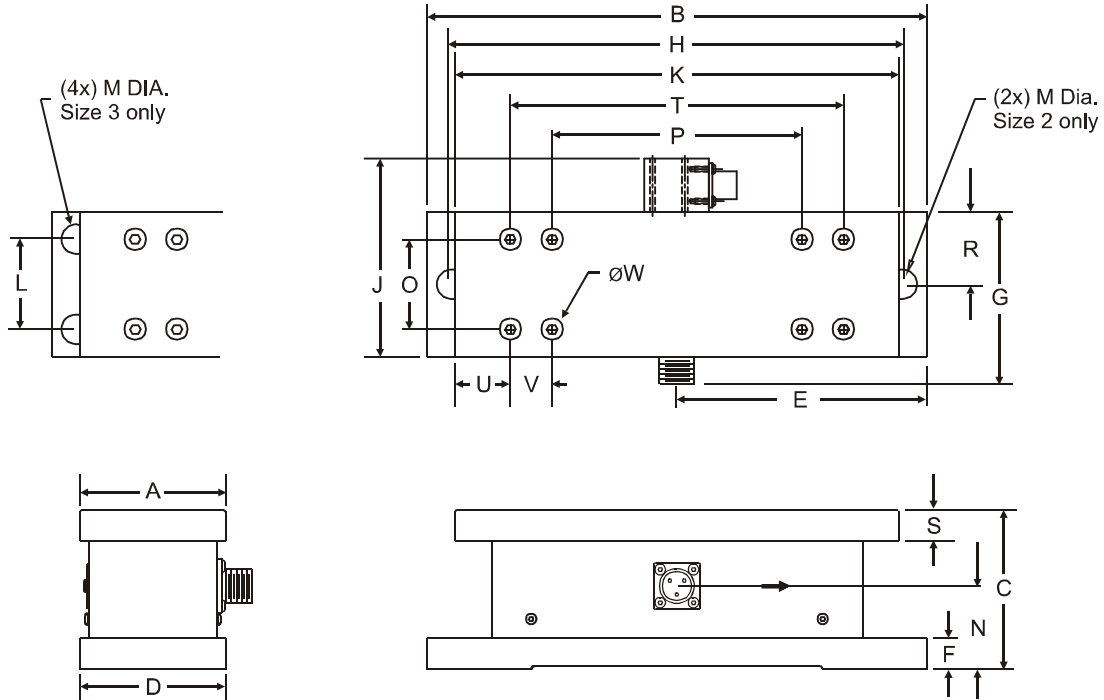

Examples of Connector Configurations:

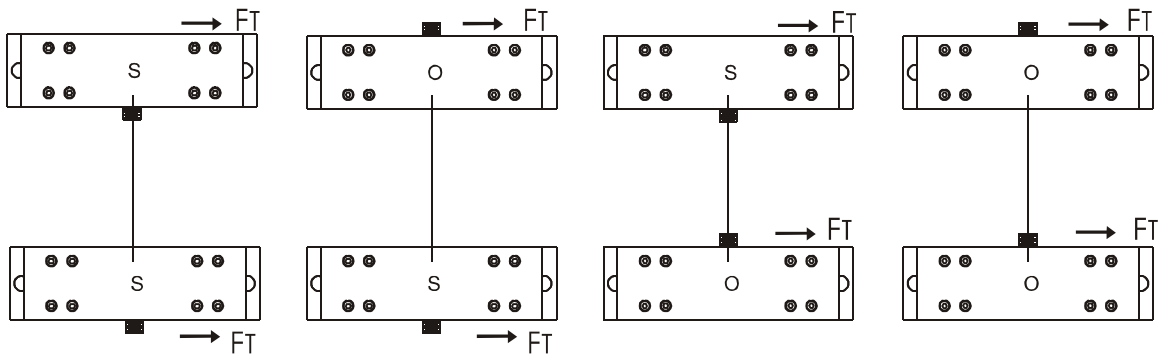

"S" DENOTES STANDARD CONNECTOR POSITION
 "O" DENOTES OPTIONAL CONNECTOR POSITION

Figure 3 - DIMENSIONS

2.2 PRE-INSTALLATION REQUIREMENTS

A. TRANSDUCER ROLL

The Model UPBH Transducers are used in pairs. One is mounted on each end of an idler roll shaft. The roll chosen is called the Transducer Roll.

1. **THE TRANSDUCER ROLL MUST BE A TRUE IDLER!** It can **NOT** be a driven roll! There can be NO brakes, clutches, belts, chains or gears attached to it or its shaft. It can not be a nip roll or be in contact with a nip roll. It can not be filled with water or have pipes or hoses attached to it. **NOTHING MUST CONTACT THE ROLL OR ITS SHAFT EXCEPT THE WEB!**
2. The Transducer Roll shaft may be non-rotating or rotating. If the shaft is rotating, it must be designed and built for rotating service. Usually this means that it is straight, dynamically balanced and strong enough to resist bending from web tension forces.
3. The roll must be **DYNAMICALLY BALANCED** if web speed is over 300 FPM! Refer to **Section 2.3.3: BALANCE THE ROLL** for specifications. An unbalanced roll will reduce the accuracy of the tension signal.

B. TENSION ZONE

The roll must be located in the tension zone which is to be monitored or controlled. The beginning or end of any tension zone is always at a nip (driven or braked), unwind shaft, rewind shaft or drag bar. Any element in the web path that can change web tension is at one end of a tension zone.

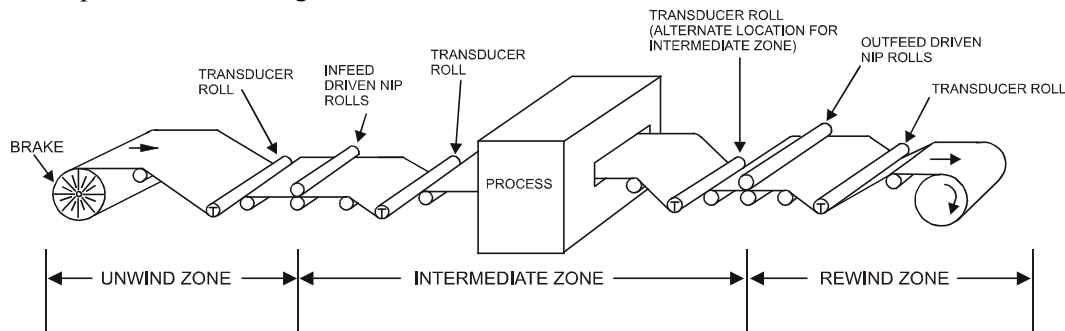

Figure 4 - TENSION ZONES

C. WRAP ANGLE

The web must always contact the transducer roll in exactly the same way. The wrap angle must not change as the unwind or rewind roll diameter changes. Therefore there must be at least one idler roll between the transducer roll and the unwind or rewind shaft. If the machine has more than one webbing path, be sure to choose a roll that is wrapped the same for each. Otherwise it will be necessary to install an additional pair of transducers, or dual calibration circuitry, or both. If the wrap angle is allowed to change, the transducer output will change with angle as well as tension, and accuracy will be reduced. The transducer roll must be wrapped such that the resultant tension force is mostly parallel to the top plate of the UPB transducer. Any force perpendicular to the top plate will not produce any output.

D. MOUNTING SURFACE

The structure on which the transducers are mounted **MUST** be very stable and strong. Any movement of the structure may be sensed by the transducers and may cause inaccurate tension readings. The surfaces must also be smooth and flat so the transducers won't be uneven when they are installed.

2.3 INSTALLING THE TRANSDUCERS

Model UPBH Transducers are very easy to install. Normally, both transducers are mounted on the machine and the roll is then installed on them. Follow the simple steps below.

1. MOUNT THE TRANSDUCERS ON THE MACHINE

Mount the transducers on the machine making sure that the transducers are facing in the direction of the tension force (See Figure 5). The tension force arrow on the transducers denotes the proper direction for the transducers. The load force direction acts parallel to the top plate and should never exceed an angle of 45° with the top plate. Significant differences may result in unsatisfactory performance.

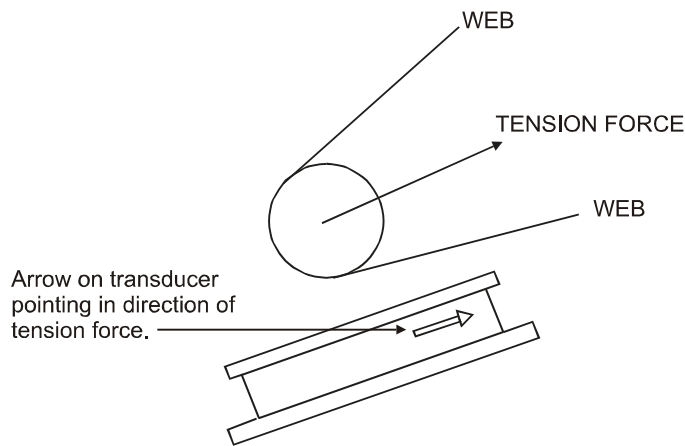

Figure 5 - TENSION FORCE DIRECTION

2. DETERMINE SHAFT LENGTH

Measure the center to center distance between the transducer bases, (call this D_T). Use the following formula to determine the minimum shaft length: $\text{SHAFT LENGTH} = D_T + 4 \frac{1}{8}'' + \text{width of one pillow block bearing}$

3. BALANCE THE ROLL

The roll must be dynamically balanced if web speed is 300 FPM or more. Balance the roll to Quality Grade G-2.5 as described in ISO 1940 and ANSI S2.19-75 standards. If these standards are not available, please contact **DOVER FLEXO ELECTRONICS** and we will provide the appropriate data.

4. SELECTION OF PILLOW BLOCK BEARING

The bearing should have self-aligning and floating capabilities. The self-aligning feature will avoid unnecessary stress on the transducers caused by misalignment during installation and by roll deflection. The floating feature will avoid forces caused by temperature variations of the shaft. These factors could cause inaccurate output from the transducers. Normally, only one bearing needs to float (move axially a small amount). The other can be fixed. A 100° F temperature change causes approximately 1/8" change in length of a 10 ft. long piece of steel.

5. REMOVE THE TOP PLATE TO DRILL FOR THE PILLOW BLOCK BEARING

1. Remove the eight screws holding the top plate to the transducer.
2. Remove the top plate and drill and tap the holes for the pillow block bearing being used.
3. Replace the top plate and secure with the eight screws. Tighten the screws as follows: Size 2 to 9 ft.lbs. (12 N.m) or torque, Size 3 to 29 ft.lbs. (39 N.m) of torque.

6. INSTALL THE ROLL AND BEARINGS ON THE TRANSDUCERS

1. Place the bearings loosely on the roll shaft.
2. Place the bearings and roll on the transducers and mount the bearings to the transducers with the appropriate cap screws. The length of the cap screws should be sufficient to anchor the bearings, but not so long as to exceed the maximum thread engagement with the top plate (0.437" for the UPBH2, 0.94" for Size 3 UPBH). If the cap screw is too long, the bearing will not clamp tightly to the top plate and the screw will interfere with load transfer to the sensing beam. See Figure 6.

CAUTION! Do not use a bolt which is too long!

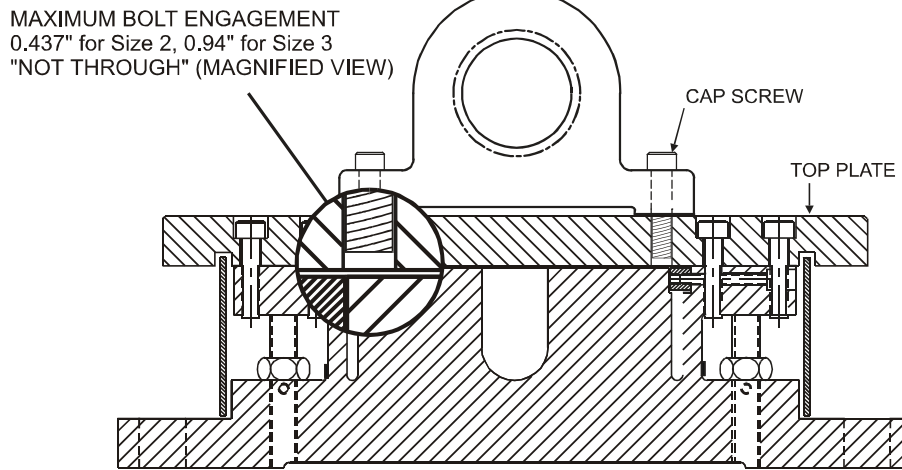

Figure 6 - BEARING MOUNTING BOLT LENGTH

3. Fasten the shaft in the bearings at this time. Be sure the floating bearing is installed with the axial gap on the side of the bearing facing the shaft end so the shaft can grow in length as it gets hot, without causing stress on the bearing.

7. CONNECT TRANSDUCER TO ELECTRONICS

Make your connections to your electronics by plugging in the cables, being careful to align the connectors properly - never force them together. Tighten the connectors to properly seat the pins.

3.1 INTRODUCTION

There are no calibration adjustments on the Model UPBH Transducer itself. The instructions below are for the electronics which the transducers are connected to. All of the following terminology and procedures, assume that the transducers are connected to a **DOVER FLEXO ELECTRONICS** tension controller or tension indicator. If some other electronics are being used, you should follow the instructions furnished with it.

These are general instructions which are correct for most **DFE** controllers and indicators, and are placed here for your convenience. If you have any difficulty calibrating or if there is any discrepancy between these instructions and those in the Instruction Manual for the indicator or controller, you should disregard these instructions and follow the instructions in the Manual for the indicator or controller.

The transducers must be properly installed and orientated as directed in **SECTION 2.3**.

3.2 ZERO THE TENSION METER

1. Turn the "POWER" switch off. If the meter does not read zero, turn the mechanical adjustment screw on the meter face so the needle indicates zero tension.
2. Find an object that weighs at least 25% of the maximum value on the tension meter scale. (Be sure you know the exact weight).
3. Find a rope, tape, or wire that will support the weight in 2. above.
4. Verify that there is no web contacting the Transducer Roll. Turn the "POWER" switch on. Wait a few seconds for the tension meter to settle. Turn the "CALIBRATE" pot. to approximately 75%. Then, turn the "ZERO" pot. so the tension meter reads zero tension.

3.3 CALIBRATE THE TENSION METER

See Figure 7. Pass the rope over the Transducer Roll in exactly the same path as the web follows. Tie the end in the machine at least one idler roll beyond the Transducer Roll. Pass the other end by at least one idler roll before the Transducer Roll. Be sure the rope does not pass over any driven rolls, braked rolls or dead bars. (This will cause inaccurate calibration). Attach the weight to the free end of the rope and let it hang without touching anything. Turn the "CALIBRATE" pot. so the tension meter reads the same as the weight. Remove the weight and rope. This concludes the calibration procedure.

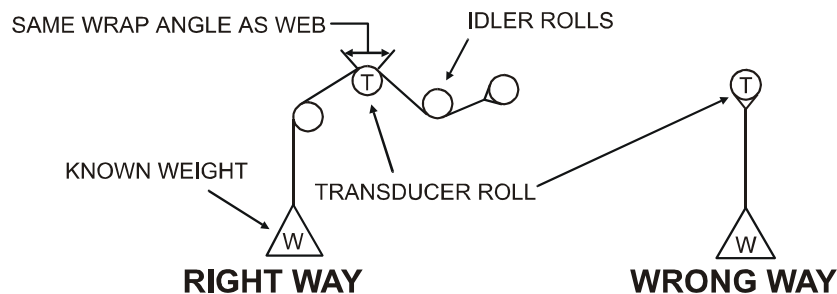

Rope follows web path exactly. All rolls must be free turning idlers.

Figure 7 - WEB PATH

Your Dover Flexo Model UPBH Tension Transducers have been manufactured of quality materials. With proper application and installation your transducers will be relatively maintenance free and long lasting. Any changes in your application which affect the dynamics of your equipment such as web speed, net force, material, etc. could possibly require upgrading of load rating or roll change. Contact Dover for specific information and engineering approval.

4.1 PROCEDURE FOR REMOVING ROLL AND PILLOW BLOCKS

To remove the transducers follow the procedure below to remove the roll and bearings from the transducers.

1. Support the idler roll so it won't fall.
2. Remove the bolts from the bearings on each transducer.
3. Take the roll and bearings off of the transducers.

4.2 PROCEDURE FOR REMOVING TRANSDUCERS

1. Disconnect the electrical cable on each transducer.
2. Remove the two or four screws mounting the transducer and repeat for the opposite side.

4.3 PROCEDURE FOR CHANGING ELECTRICAL CONNECTOR POSITION

The electrical connector can be placed in two positions relative to the machine frame, inside or outside. It may be changed easily by following the procedure below.

1. Remove all eight screws from the top plate of the transducer, and remove the top plate.
2. Remove the four button head screws on the connector. Move connector from its mounting hole being careful not to break electrical wires. De-solder wires from connector.
3. Remove the four button head screws from the shroud. Slide the shroud off the transducer and rotate it 180 degrees. With the shroud rotated replace it back on the transducer. While sliding the shroud down the transducer place the electrical wires out through the connector hole.
4. Resolder the electrical wires to the connector in the following pattern:
PIN A = WHITE WIRE
PIN B = BLACK WIRE
PIN C = RED WIRE
5. Replace connector into the shroud and fasten with its button head screws. Also replace the button head screws for the shroud.
6. Replace top plate and secure it with the eight screws removed earlier. Torque screws to 6 ft./lbs.

This is a list of problems which could occur during initial start-up or afterwards. The probable causes are listed with the most likely one first and the least likely one last.

1. TRANSDUCER ROLL SHAKES, VIBRATES or BOUNCES

- a. Roll is not balanced. See Section 2.3.3 and Section 2.2.A.3.
- b. Shaft is not clamped tightly in bearings. Mounting screws are loose or shaft diameter is undersize.
- c. Transducer mounting bolts are not tight.
- d. Shaft is too weak or there is too much shaft extension between the ends roll and the transducers.
- e. Shaft is bent or too weak. (This refers to live shaft idler rolls, only)
- f. Roll is turning at its natural frequency. Call **DFE** for analysis of conditions and solution to problem.

2. CAN NOT ADJUST TENSION METER TO READ ZERO WHEN WEB IS SLACK

- a. Transducer roll is too heavy. See Appendix B.
- b. Transducers are pre-loaded. See Sections 2.3.2 and 2.3.4.

3. TENSION METER READS BACKWARDS

- a. Transducers are installed backwards with force arrow pointing in opposite direction. See Section 2.3.1.
- b. Transducer cables are connected wrong at controller/indicator terminal strip. Signal wires are reversed.

4. TENSION METER NEEDLE PEGS HIGH OR LOW

- a. Meter is not electrically adjusted to zero. See Section 3.2
- b. Transducers are pre-loaded. See Sections 2.3.2 and 2.3.4.
- c. Transducer cable has broken wire, poor connection or short circuit.
- d. A strain gage has failed. To verify: Unplug the transducer cable and use an ohm-meter to measure the resistance of the gages at the connector on the transducer. Measure between pins A,B, and A,C. In each case, the resistance should be about 100 ohms. Measure the resistance between any pin and the outside of the transducer. The meter should read infinite resistance. Apply a force to the roll by hand or by using a rope and a weight, in the direction of the tension force and maintain it while again measuring between pins A,B and A,C. The resistance should be only a few ohms different from before.
- e. Failure in the tension amplifier circuit of the controller/indicator.

5. TENSION METER DOES NOT READ ZERO WHEN WEB IS SLACK AND READING DRIFTS WITH TIME.

- a. Meter is not calibrated. See Section 3.3.
- b. Transducers are pre-loaded. See Sections 2.3.2 and 2.3.4.
- c. The structure the transducers are mounted on is weak. See Section 2.2.D.
- d. Transducer cable has a broken wire, poor connection or short circuit.
- e. A strain gage is cracked. Perform the test in 4d above.

6. TENSION METER DOES NOT READ THE SAME EACH TIME THE SAME FORCE IS APPLIED (poor repeatability)

- a. Transducers are pre-loaded. See Sections 2.3.2 and 2.3.4.
- b. The structure the transducers are mounted on is weak. See Section 2.2.D.
- c. The bearing or transducer mounting screws are loose.

7. TENSION METER READING DOES NOT CHANGE WHEN FORCE IS APPLIED TO ROLL. METER READS ZERO.

- a. Meter is not calibrated. See Section 3.3.
- b. Force direction arrow on one transducer is backwards. See Section 2.3.1.
- c. Transducer roll is too heavy. See Appendix B.
- d. Transducer cable has broken wire, poor connection or short circuit.
- e. Transducer cables connected incorrectly, or to wrong transducers.
- f. Failure of tension amplifier circuit in controller/indicator. Unit not turned on.

8. TENSION METER NEEDLE BOUNCES

- a. Web tension is fluctuating because of machine speed fluctuations, bent roll shafts, worn idler roll bearings, chattering unwind brake, flat spot in unwind or rewind roll, etc.
- b. Shaft is loose in the bearings. Bearing mounting screws are loose or shaft diameter is under-size.
- c. Transducer mounting bolts are loose.
- d. Tension controller is not adjusted properly. See controller Instruction Manual for procedure.

6.1 REPLACEMENT PARTS FOR THE UPBH TRANSDUCER

Top Plate	203-0123
Electrical Connector, MS3102A-10SL	106-0070

<u>CABLES:</u>	<u>15 Ft.</u>	<u>20 Ft.</u>	<u>25 Ft.</u>	<u>30 Ft.</u>
C - C:	721-1554	721-1539	721-1540	721-1541
w/ Rt. Angle Conn	721-0083			
C - N:	721-1555	721-1542	721-1543	721-1544
w/Rt. Angle Conn	721-0155			

Instruction Manual: Doc 801-0672 R1

Call **Customer Service** for prices and for part numbers of items not listed. For help with service or repairs, call **Technical Service**. We can be reached by the following:

Phone: 603-332-6150

Fax: 603-332-3758

E-mail: Customer Service: customerservice@dfc.com

Technical Service: techsupport@dfc.com

MODELS C, RS, AND UPB TRANSDUCERS

THE TENSION (T) AND COMPRESSION STRAIN GAGES ARE CONNECTED IN A BRIDGE CONFIGURATION. AS THE BEAMS BEND SLIGHTLY UNDER WEB TENSION, THE GAGE RESISTANCES CHANGE PRODUCING AN OUTPUT SIGNAL WHICH IS DIRECTLY PROPORTIONAL TO THE WEB TENSION.

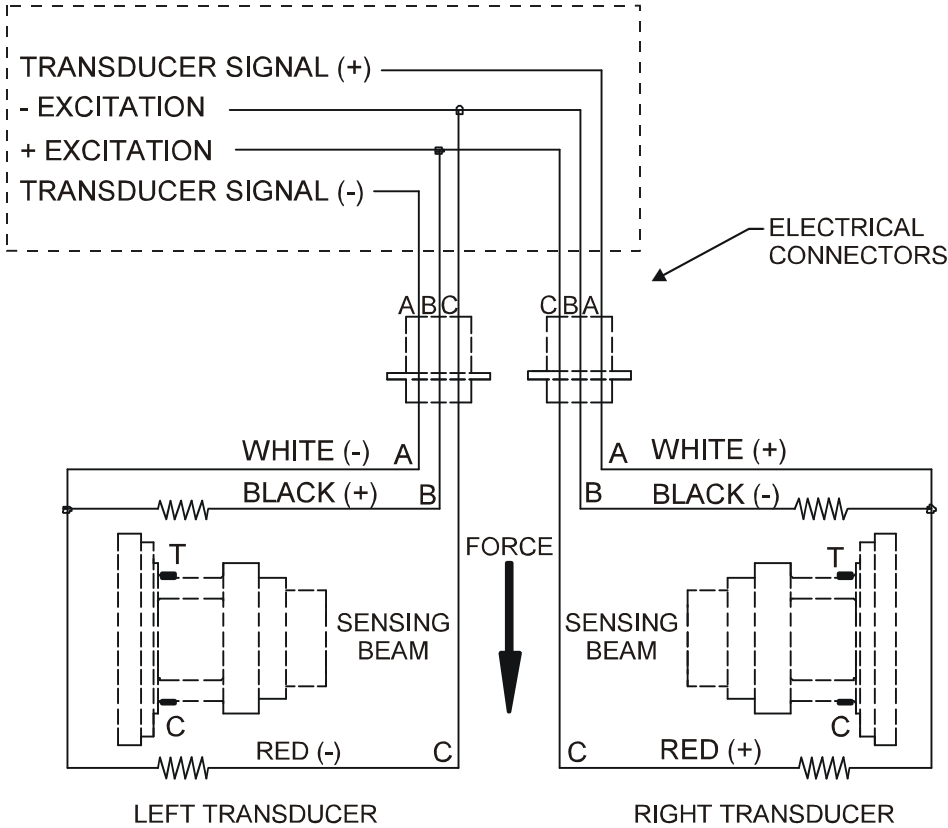

Figure 8 - MODEL UPB TRANSDUCER WIRING

Appendix B:

Selection of Load Rating

The Model UPBH Transducer is available in several standard load ratings, ranging from 100 lbs. (450 N) to 5000 lbs. (22250 N). The correct rating for any particular application depends on web tension, transducer roll weight, wrap angle and the direction of the tension force. Select the appropriate wrap configuration from the sketches below and apply the formula below the sketch.

- ! The Model UPBH transducer is sensitive to forces **parallel** to its top plate.
- ! Angle "D" should be as small as possible. Output will rapidly drop as D gets larger. Do not exceed 45°.
- ! If A = 0, idler weight will not produce any output signal.

Use the chart at bottom of page to select the correct load rating. In some cases, the load rating may be LESS than the computed Net Force. This is acceptable because the Net Force formula contains an oversizing factor of 2.

Sometimes the weight of a transducer roll uses up most of the operating range of the transducers. When this happens, it may not be possible to adjust the tension indicating meter to read zero when tension is zero because the adjustment range of the electronic circuit has been exceeded. If the effective roll weight, represented by the "WSIN(A)" term in the formulae below, is more than 95% of the load rating chosen, the tension meter will probably not be adjustable to zero. If this is the case, one or more of the following changes must be made to reduce WSIN(A).

- A. Reduce the transducer roll weight.
- B. Decrease angle (A).
- C. Use the next higher load rating. (This is the least desirable choice because it reduces the transducer output signal).

Recommended Roll Weight Maximums:

- 100 lbs load rating - 400 lbs max roll wt
- 200 to 400 lbs load rating - 100 lbs max roll wt
- 800 to 1200 lbs load rating - 2500 lbs max roll wt

- FT = force due to tension
- W = idler roll weight
- B = wrap angle = 180° - C
- A = angle between line "v" and vertical
- D = angle between top plate and direction of force
- Line H is parallel to top plate
- Line V is perpendicular to top plate

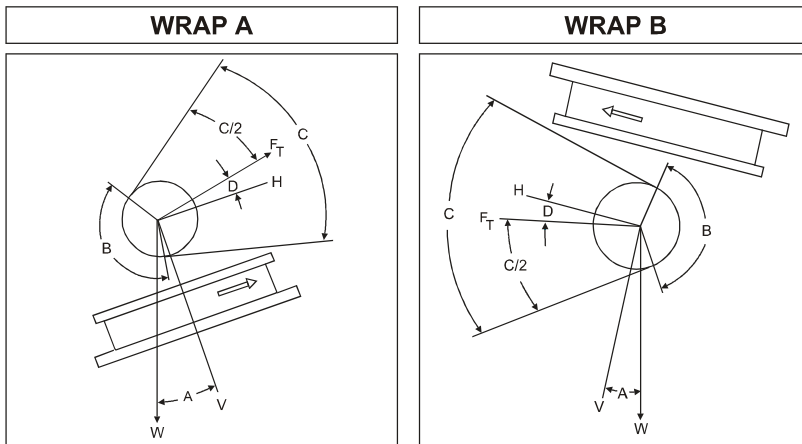

$$\text{Net Force} = \frac{4T \sin\left(\frac{B}{2}\right) \cos(D) - W \sin(A)}{2}$$

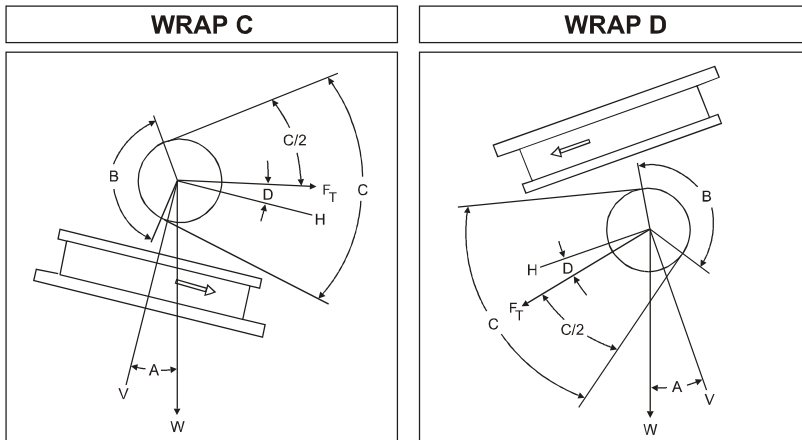

$$\text{Net Force} = \frac{4T \sin\left(\frac{B}{2}\right) \cos(D) + W \sin(A)}{2}$$

Angle (Degrees)	SINE	COSINE
0	.000	1.000
5	.087	.996
10	.174	.985
15	.259	.966
20	.342	.940
25	.423	.906
30	.500	.866
35	.574	.819
40	.643	.766
45	.707	.707
50	.766	.643
55	.819	.574
60	.866	.500
65	.906	.423
70	.940	.342
75	.966	.259
80	.985	.174
85	.996	.087
90	1.000	.000

Use this chart to select the correct load rating

Size	Net Force (lb.)	Load Rating
2	up to 120	100 lbs. (450 N)
	121 - 240	200 lbs. (900 N)
	241 - 480	400 lbs. (1800 N)
	481 - 960	800 lbs. (3600 N)
	961 - 1440	1200 lbs. (5350 N)
3	up to 1200	1000 lbs (4450 N)
	1201 - 3000	2500 lbs (11125 N)
	3001 - 6000	5000 lbs (22250 N)

FORMULAS FOR NET FORCE FROM ROLL WEIGHT

Appendix C: Typical Tensions for Various Materials

TYPICAL TENSIONS FOR WEB MATERIALS

ACETATE		0.5 lb. per mil per inch of width	
FOIL	Aluminum	0.5 lb. per mil per inch of width	
	Copper	0.5 lb. "	
CELLOPHANE		0.75 lb. per mil per inch of width	
NYLON		0.25 lb. per mil per inch of width	
PAPER	15 lb *	0.4 lb. per inch of width	
	20 lb	0.5 lb. "	
	30 lb	0.75 lb. "	
	40 lb	1.25 lb. "	
	60 lb	2.0 lb. "	
	80 lb	3.0 lb. "	
	100 lb	4.0 lb. "	
	* based on 3000 sq. ft. ream		
PAPERBOARD	8pt	3.0 lb. per inch of width	
	12pt	4.0 lb. "	
	15pt	4.5 lb. "	
	20pt	5.5 lb. "	
	25pt	6.5 lb. "	
	30pt	8.0 lb. "	
POLYETHYLENE		0.12 lb. per mil per inch of width	
POLYESTER (Mylar)		0.75 lb. per mil per inch of width	
POLYPROPYLENE		0.25 lb. per mil per inch of width	
POLYSTYRENE		1.0 lb. per mil per inch of width	
RUBBER	<u>GAUGE</u>	<u>AT 25% STRETCH</u>	<u>AT 50% STRETCH</u>
	10 mil	1.75	3.68
	12 mil	1.10	2.03
	16.5 mil	4.09	8.17
	26 mil	2.47	4.97
SARAN		0.15 lb per mil per inch of width	
STEEL	<u>GAUGE - INS</u>	<u>UNWIND-PSI</u>	<u>REWIND-PSI</u>
	.001 -.005	1000	4000
	.006 -.025	850	3500
	.026 -.040	750	3000
	.041 -.055	650	2600
	.058 -.070	550	2200
	.071 -.090	450	1800
	.091 -.120	450	1400
	.121 -.140	400	1200
	.141 -.165	400	1000
	.166 -.200	400	900
	.201 -.275	400	800
	.276 -.380	300	700
VINYL		0.05 lb. per mil per inch of width	

*** For laminated webs, sum the tension for the individual webs and add 0.1 lb per inch of width.

TERMS AND CONDITIONS OF SALE AND SHIPMENT

1. THE COMPANY

5/1/00

Dover Flexo Electronics, Inc. is hereinafter referred to as the Company.

2. CONFLICTING OR MODIFYING TERMS

No modification of, additions to or conflicting provisions to these terms and conditions of sale and shipment, whether oral or written, incorporated into Buyer's order or other communications are binding upon the Company unless specifically agreed to by the Company in writing and signed by an officer of the Company. Failure of the Company to object to such additions, conflicts or modifications shall not be construed as a waiver of these terms and conditions nor an acceptance of any such provisions.

3. GOVERNING LAW

This contract shall be governed by and construed according to the laws of the state of New Hampshire, U.S.A. The parties agree that any and all legal proceedings pursuant to this contract shall take place under the jurisdiction of the courts of the State of New Hampshire in the judicial district of Strafford County.

4. PENALTY CLAUSES

Penalty clauses of any kind contained in orders, agreements or any other type of communication are not binding on the Company unless agreed to by an officer of the Company in writing.

5. WARRANTY

Dover Flexo Electronics, Inc. warrants its' products to be free of defects in material and workmanship for five years from date of original shipment. Warranty is valid on products purchased on or after April 2, 1999. During the warranty period the Company will repair or replace defective products free of charge if such products are returned with all shipping charges prepaid and if, upon examination, the product is shown to be defective. This warranty shall not apply to products damaged by abuse, neglect, accident, modification, alteration or mis-use. Normal wear is not warranted. All repairs and replacements under the provisions of this warranty shall be made at Dover Flexo Electronics or at an authorized repair facility. The Company shall not be liable for expenses incurred to repair or replace defective products at any other location or by unauthorized persons or agents. This warranty contains all of the obligations and warranties of the Company. There are no other warranties, either expressed or implied. No warranty is given regarding merchantability or suitability for any particular purpose. The Company shall not be liable in either equity or law for consequential damages, losses or expenses incurred by use of or inability to use its' products or for claims arising from same. No warranty is given for products of other manufacturers even though the Company may provide these products with its' own or by themselves. The provisions of this warranty can not be changed in any way by any agent or employee of the Company. Notice of defects must be received within the warranty period or the warranty is void.

6. PAYMENTS

Standard terms of credit are net 30 days from date of shipment, providing satisfactory credit is established with the Company. Amounts past due are subject to a service charge of 1.5% per month or portion thereof or 18% per annum. The Company reserves the right to submit any unpaid late invoices to a third party for collection and Buyer shall pay all reasonable costs of such collection in addition to the invoice amount. All quoted prices and payments shall be in U.S. Dollars.

If the Company judges that the financial condition or payment practices of the Buyer does not justify shipment under the standard terms or the terms originally specified, the Company may require full or partial payment in advance or upon delivery. The Company reserves the right to make collection on any terms approved in writing by the Company's Finance Department. Each shipment shall be

considered a separate and independent transaction and payment therefore shall be made accordingly. If the work covered by the purchase order is delayed by the Buyer, upon demand by Company payments shall be made on the purchase price based upon percentage of completion.

7. TAXES

Any tax, duty, custom, fee or any other charge of any nature whatsoever imposed by any governmental authority on or measured by any transaction between the Company and the Buyer shall be paid by the Buyer in addition to the prices quoted or invoiced.

8. RETURNS

Written authorization must be obtained from the Company's factory before returning any material for which the Buyer expects credit, exchange, or repairs under the Warranty. Returned material (except exchanges or repairs under the Warranty) shall be subject to a minimum re-stocking charge of 15%. Non-standard material or other material provided specially to the Buyer's specification shall not be returnable for any reason. All material returned, for whatever reason, shall be sent with all freight charges prepaid by the Buyer.

9. SHIPPING METHOD AND CHARGES

All prices quoted are F.O.B. the Company's factory. The Company shall select the freight carrier, method and routing. Shipping charges are prepaid and added to the invoice of Buyers with approved credit, however the Company reserves the right to ship freight-collect if it prefers. Shipping charges will include a charge for packaging. Company will pay standard ground freight charges for items being returned to Buyer which are repaired or replaced under the Warranty.

10. CANCELLATION, CHANGES, RESCHEDULING

Buyer shall reimburse Company for costs incurred for any item on order with the Company which is canceled by the Buyer. Costs shall be determined by common and accepted accounting practices. A one-time hold on any item ordered from the Company shall be allowed for a maximum of 30 days. After 30 days, or upon notice of a second hold, Company shall have the right to cancel the order and issue the appropriate cancellation charges which shall be paid by Buyer. Items held for the Buyer shall be at the risk and expense of the Buyer unless otherwise agreed upon in writing. Company reserves the right to dispose of canceled material as it sees fit without any obligation to Buyer. If Buyer makes, or causes to make, any change to an order the Company reserves the right to change the price accordingly.

11. PRICES

Prices published in price lists, catalogs or elsewhere are subject to change without notice and without obligation. Written quoted prices are valid for thirty days only.

12. EXPORT SHIPMENTS

Payment for shipments to countries other than the U.S.A. and Canada or to authorized distributors shall be secured by cash in advance or an irrevocable credit instrument approved by an officer of the Company. An additional charge of 10% will apply to any letter of credit. There will be an extra charge for packaging and documentation.

13. CONDITION OF EQUIPMENT

Buyer shall keep products in good repair and shall be responsible for same until the full purchase price has been paid.

14. OWNERSHIP

Products sold are to remain the property of the Company until full payment of the purchase price is made.

DECLARATION OF CONFORMITY

We,

Dover Flexo Electronics
217 Pickering Road
Rochester, NH 03867 USA
Tel: (603) 332-6150
Fax: (603) 332-3758

declare under our sole responsibility that the product:

Model UPB2 Web Tension Transducer,

manufactured after the date 1 May 1997, and to which this declaration relates, is in conformity with the following standards or other normative documents:

EN 55011: Radiated and Conducted Emissions
EN 50082-2: Electromagnetic compatibility - Generic immunity standard,
Part 2. Industrial Environment, to include:
ENV 50140: Radio Frequency Immunity - AM
ENV 50141: Conducted Radio Frequency Interference
ENV 50204: Radio Frequency Immunity - Pulse Modulated
ENV 61000-4-2: Electrostatic Discharge
EN 61000-4-4: Electrical Fast Transient Bursts

following the provisions of Council Directive 89/336/EEC of 3 May 1989 on the approximation of the laws of the member states relating to electromagnetic compatibility (the "EMC Directive").

The Technical Construction File is maintained at:

Dover Flexo Electronics
217 Pickering Road
Rochester, NH 03867 USA

Per Annex II R of the Machinery Directive (89/392/EEC):

The machinery, product, assembly, or sub-assembly covered by this Declaration of Conformity must not be put into service until the machinery into which it is to be incorporated has been declared in conformity with the provisions of the applicable Directive(s).

Date of issue: 5 May, 1997

Place of issue: Rochester, NH USA

Signed: _____

Alan H. Wysocki

Alan H. Wysocki, Engineering Manager

8010717a.doc

NOTES

INDEX

Bearing, selection of	6	Options	3
Cables	3, 12	Output	3
Calibration of tension meter	8	Overload	3
Care and Maintenance	9	Pillow Block Bearing	6, 9
Declaration of Conformity	17	Repeatability	3
Deflection	3	Replacement Parts	12
Description	1	Specifications	3
Dimensions	4	Strain gages	1, 2, 14
Drill and Tap	3	configuration	2
Dynamically balanced	5, 6	Temperature	
Electrical connections	3, 11	coefficient	3
transducer	13	range	3
Electrical connector	3, 12	Tension Force	6, 14
environmental	3	Tension Zone	5
position	4, 9	Terms and Conditions	16
right angle	3, 12	Top Plate.....	1, 3, 4, 6, 12
Electrical Operation	2	Transducer	
Excitation Voltage	3	roll	5, 9
Extended Range	3	balance	6
Features, std.	3	electrical connections	13
Formulas, Net Force	14	Shaft length	6
Full Bridge	3	removal	9
Installation	4-7	Troubleshooting	10-11
Linearity & Hysteresis combined	3	Typical Tensions	15
Load direction	3	Web path	8
Load ratings	3	Weight	3
selection of	14	Wheatstone bridge	2, 3
Material	3	Wrap angle	5
Mounting	5	Zero	8
positions	5-6, 14		
surface	5		



217 PICKERING ROAD
ROCHESTER, NEW HAMPSHIRE 03867-4630 U.S.A
TEL: 603-332-6150
FAX: 603-332-3758
E-mail: info@dfe.com Internet: www.dfe.com

CANADA

MEXICO

UNITED KINGDOM

EUROPE

TAIWAN

KOREA

AUSTRALIA

COLOMBIA

INDIA

SOUTH AFRICA