



THE TENSION CONTROL SPECIALISTS

# INSTRUCTION MANUAL



## Filament Tri-Wheel™ Tension Load Cell Model TW-50W

DOC 801-0007 R1

**Dover Flexo Electronics, Inc.**  
**307 Pickering Road**  
**Rochester, NH 03867- 4630**  
**U.S.A.**

**FOR ASSISTANCE:**

**TECHNICAL SERVICE** - Installations, Start-Up, Troubleshooting, Repairs, Field Service or Returns. **Call (603) 332-6150 and ask for Technical Support or email us at: [techsupport@dfc.com](mailto:techsupport@dfc.com)**

**CUSTOMER SERVICE** - Replacement Parts, Individual Products, Questions about Orders, Manuals. **Call (603) 332-6150 and ask for Customer Service or email us at: [customerservice@dfc.com](mailto:customerservice@dfc.com)**

**SALES** - Product Information, System Application Questions or Placing Orders, **Please e-mail us at: [sales@dfc.com](mailto:sales@dfc.com) or call (603) 332-6150 and ask for Sales.**

Telephone: (603) 332-6150 Fax: (603) 332-3758

E-mail: [info@dfc.com](mailto:info@dfc.com) Internet: <https://www.dfc.com/>

## SAFETY



### This label indicates: “Read The Manual”

Make sure you read and understand all instructions and safety precautions listed in this manual before installing or operating your Tri-Wheel™ Load Cell. If you have any questions concerning the operation of your device or the information in this manual, please contact us.

Email: [techsupport@dfc.com](mailto:techsupport@dfc.com)

Telephone: (603) 332-6150

- **Observe all warning labels.**
- **Never remove warning labels.**



**WARNING:** During installation care should be taken not to drop the Tri-Wheel™ Load Cell, handle the unit with care, sudden jolts or drops can damage its components and serious injury could result.



**WARNING:** If this equipment is not connected or operated in the manner specified, the operating safety of this unit or of connected equipment cannot be guaranteed.

## Table of Contents

---

<b>DOCUMENT CONVENTIONS .....</b>	<b>5</b>
<b>1 GENERAL DESCRIPTION .....</b>	<b>6</b>
1.1 CONSTRUCTION AND MECHANICAL OPERATION.....	6
1.2 SPECIFICATIONS .....	7
1.3 STANDARD FEATURES .....	7
1.4 CONFIGURATION CHOICES.....	7
<b>2 INSTALLATION.....</b>	<b>8</b>
2.1 DIMENSIONS INCHES (MM).....	8
2.2 PRE-INSTALLATION REQUIREMENTS .....	8
2.3 INSTALLATION .....	9
2.4 ELECTRICAL OPERATION.....	10
<b>3 CALIBRATION AND SETUP .....</b>	<b>12</b>
3.1 INTRODUCTION .....	12
3.2 ZERO THE TENSION METER.....	12
3.3 CALIBRATE THE TENSION METER.....	12
<b>4 CARE AND MAINTENANCE.....</b>	<b>13</b>
<b>5 TROUBLESHOOTING.....</b>	<b>14</b>
<b>TERMS AND CONDITIONS OF SALE AND SHIPMENT .....</b>	<b>15</b>

# DOCUMENT CONVENTIONS

---

**NOTICE** **NOTES** - Highlight important concepts, decisions you must make, or the implications of those decisions.



**CAUTIONS** - Tell you when equipment may be damaged if the procedure is not followed properly.



**WARNINGS** - Tell you when people may be injured, or equipment may be damaged if the procedure is not followed properly.

Numbered lists indicate tasks that should be carried out in sequence:

1. First do this
2. Then do this

Bulleted lists are used for:

- Tasks that can be carried out in any order
- Itemized information

# 1 GENERAL DESCRIPTION

---

The *Model TW-50W Tri-Wheel™ Tension Load Cell* is an electro-mechanical device that converts filament tension into a DC voltage proportional to tension. The voltage is amplified in external electronic circuitry such as a DFE Tension Amplifier, Indicator or Closed-Loop Controller which is calibrated to output and/or display actual tension. The tension reading is expressed in pounds, ounces, grams, kilograms, newtons, or any other desirable units. It can also be supplied to a regulator circuit to control tension automatically.

The TW is typically used in applications that require turn-key setup, utilizing any of the five configurable wrap angles. Material being processed should be 6 mm in diameter or less to fit within the contact area of the ceramic pulley surfaces. The information in this section will help give a clear understanding of the TW load cell - how it works and how it's used.

## 1.1 CONSTRUCTION AND MECHANICAL OPERATION

Inside the load cell housing is a single beam having two parallel cantilevered webs with strain gages mounted on each. When tension is applied, the beam deflects a small amount, causing an electrical output from the strain gages which is directly proportional to the filament tension.

The bore of the housing acts as a mechanical stop, preventing damage to the beam and gages from accidental overloads. The stop is functional through 360 degrees, so the overload condition may occur from any direction, not just the load direction. In all cases, the beam is prevented from deflecting far enough to cause any damage.

Standard TW load cell pulleys feature ceramic inserts and polymer flanges to achieve a combination of light weight and high wear resistance. The bearings are standard deep-groove ball type with shields to discourage the entry of contaminants.



**Figure 1 –TRI-WHEEL™ TENSION LOAD CELL FIXTURE**

## 1.2 SPECIFICATIONS

### ELECTRICAL SPECIFICATIONS

**Excitation Voltage:** 5 VDC max

**Output:** 100 mV/V, nominal

**Strain Gages:** Semiconductor, 100 ohms nominal resistance

**Repeatability:** +/- 1/4% FS

**Linearity and Hysteresis Combined:** +/- 1/2% FS

**Temperature Range:** -10° F to +200° F (-23° C to +93° C)

**Temperature Coefficient:** 0.02% per degree F, typical (0.01% per degree C, typical)

**Electrical Connector:** MIL Spec - PT02E10-6P

#### Electrical Connections:

**Pin A (White):** Signal Output (-)

**Pin B (Black):** Excitation (+)

**Pin C (Red):** Excitation (-)

**Pin D (Green):** Signal Output (+)

**Pin E (Blue):** Excitation (-)

**Pin F (Brown):** Excitation (+)

#### Mating Electrical Connector:

MIL Spec (Standard) - 6 socket, female, PT06E10-6S

### MECHANICAL SPECIFICATIONS

**Materials:** 303 stainless steel, 6061-T6 and 7075-T6 aluminum, Al<sub>2</sub>O<sub>3</sub> ceramic

**Maximum Overload Capacity:** 500 lbs (2224 N) Pulley, 1200 lbs (5338 N) Load Cell

**Deflection:** .005" typical (0.127 mm typical)

**Standard Connector Position:** 6:00, 12:00 and Rear

**Load Ratings:** 10, 25, 50, 100, 200 lbs (45, 111, 222, 445, 890 N)

**Wrap Angles:** 10°, 35°, 100°, 125°, 180°

**Break-Away Torque:** 0.8 N-mm (0.11 ozf-in)

**Basic Dynamic Load Rating of Bearings:** 5.1 kN

**Pulley & Shaft Weight:** 0.45 lbs (204 g)

## 1.3 STANDARD FEATURES

**Dual Cantilever Beam:** Provides high strength and accuracy at low tension.

**Stainless Steel and Aluminum Construction:** Excellent durability and corrosion resistance.

**Bi-directional Force Measuring:** Resulting force from tension may pull up or down on the load cell axis, allowing the fixture to be mounted in the optimum position to string and hang a calibration weight for the selected wrap angle.

## 1.4 CONFIGURATION CHOICES

**Load Ratings:** 10, 25, 50, 100, 200 lbs (45, 111, 222, 445, 890 N)

**Wheel Types:** 50mm diameter diamond-polished Al<sub>2</sub>O<sub>3</sub> ceramic pulley

**Connector Positions:** 6:00, 12:00 and Rear

**Wrap angles:** 10°, 35°, 100°, 125°, 180°

# 2 INSTALLATION

## 2.1 DIMENSIONS INCHES (MM)

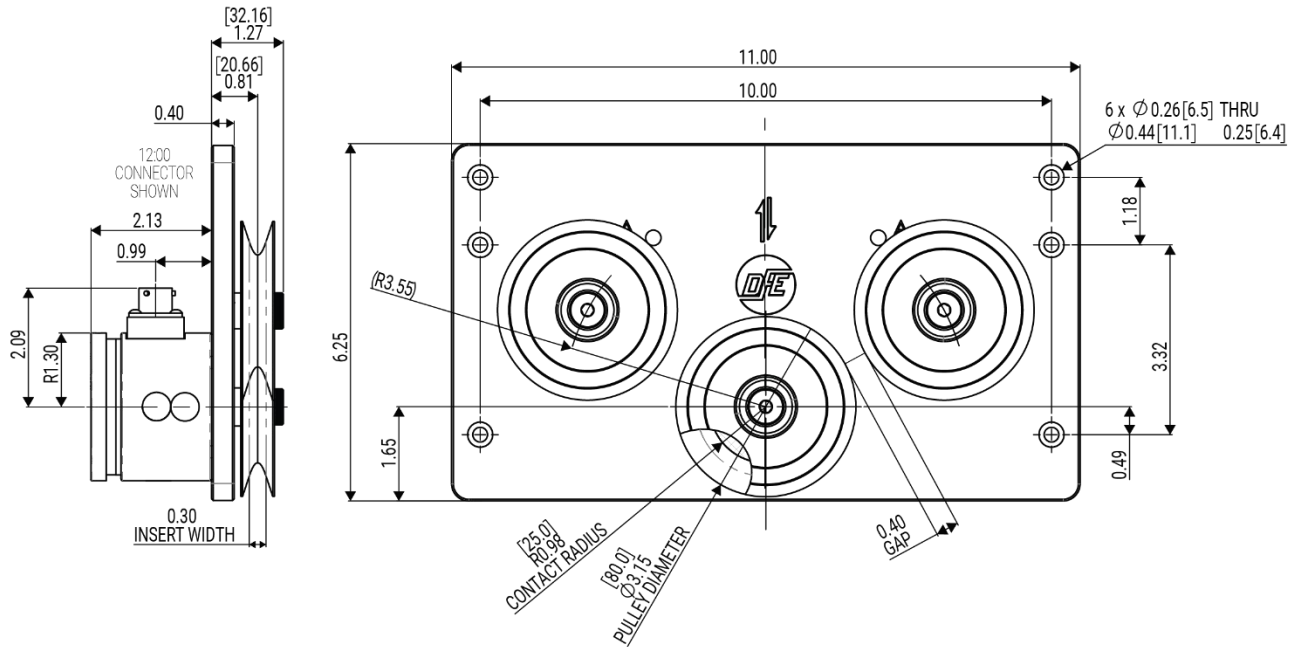

Figure 2 – DIMENSIONS

## 2.2 PRE-INSTALLATION REQUIREMENTS

**NOTICE** **Note:** No brakes, clutches, belts, chains, or gears should be attached to the load cell wheel. It cannot be a nip roll or be in contact with a nip wheel. **Nothing must contact the wheel except the filament.**

### 1. TENSION ZONE

The load cell must be located in the tension zone which is to be monitored or controlled. The beginning or end of any tension zone is always at a nip (driven or braked), unwind shaft, rewind shaft, or drag bar. Any element in the filament path that can change tension is at one end of a tension zone.

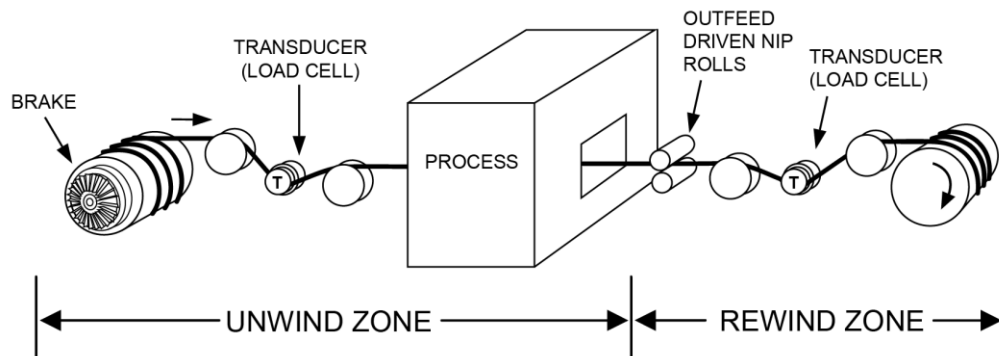

Figure 3 – TENSION ZONES



## 2. MOUNTING SURFACE

The structure on which the load cell fixture is mounted must be very stable and strong. Any movement of the structure may be sensed by the load cell and may cause inaccurate tension readings. The surfaces must also be smooth and flat so the load cell can be properly aligned during installation.

## 2.3 INSTALLATION

Model TW load cell is very easy to install.

### 1. ORIENT THE FIXTURE PLATE (see Figures 4 and 5)

The load cell assembly must be oriented so the entry and exit of material is in line with the process path. Use the mounting orientations below for the required wrap angle, this will provide the best position for hanging your calibration weight later during setup.

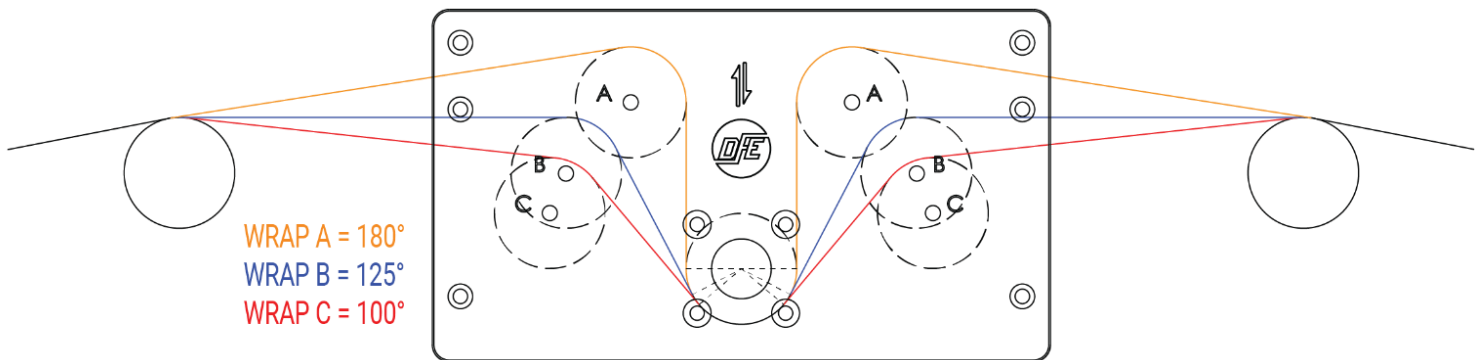

**Figure 4** – Mount right-side up for 100°, 125° & 180° wrap angle

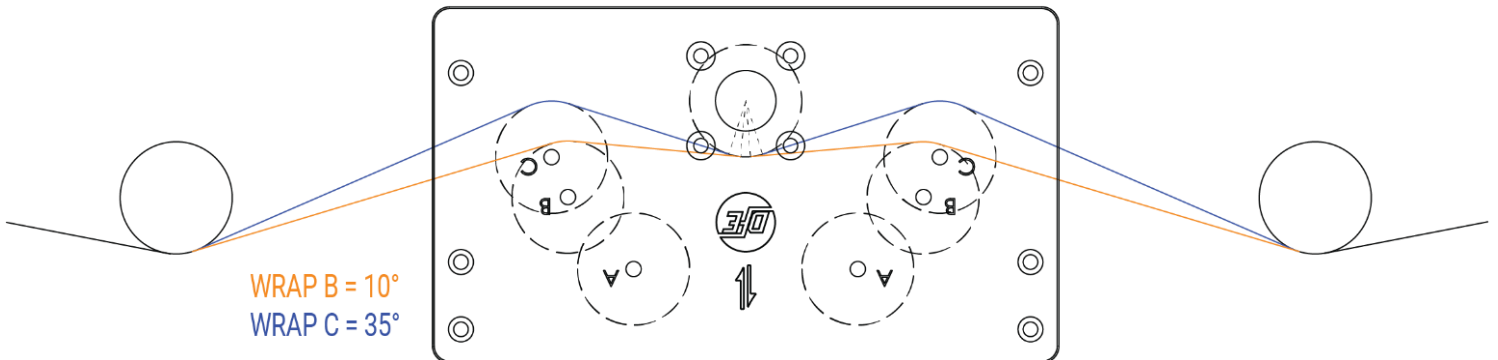

**Figure 5** – Mount inverted for use with 10° & 35° wrap angle

## 2. INSTALL AND TIGHTEN MOUNTING FASTENERS

With the load cell fixture properly oriented, install mounting fasteners and tighten to secure the load cell fixture in place.



**WARNING:** During installation care should be taken not to drop the TW load cell, handle with care. Sudden jolts or drops can damage its components and serious injury could result.

## 3. CONNECT LOAD CELL TO ELECTRONICS

Make your connection to your electronics by plugging in the cable, being careful to align the connectors properly - never force them together. Tighten the connectors to properly seat the pins.



**CAUTION:** If a non-standard DFE wheel or shaft assembly is used, make certain its weight does not exceed the load rating of the load cell or rub on the fixture plate surface, as either condition will interfere with the proper function of the system.

## 2.4 ELECTRICAL OPERATION

The Model TW load cell (also referred to as “transducer”) is used singularly. Filament tension exerts a force on the wheel which is transmitted to the cantilever beam. Four semiconductor strain gages are mounted on the beam, two on the top and two on the bottom. As force is applied and the beam deflects, the top gages are stretched, and the bottom gages are compressed. This increases the electrical resistance of the top gages and decreases the resistance of the bottom gages. The gages are electrically connected in a Wheatstone bridge configuration. The output from the bridge is the sum of the output from sets of gages.

THE TENSION (T) AND COMPRESSION (C) STRAIN GAGES ARE CONNECTED IN A BRIDGE CONFIGURATION. AS THE BEAMS BEND SLIGHTLY UNDER WEB TENSION. THE GAGE RESISTANCES CHANGE PRODUCING AN OUTPUT SIGNAL WHICH IS DIRECTLY PROPORTIONAL TO THE WEB TENSION.

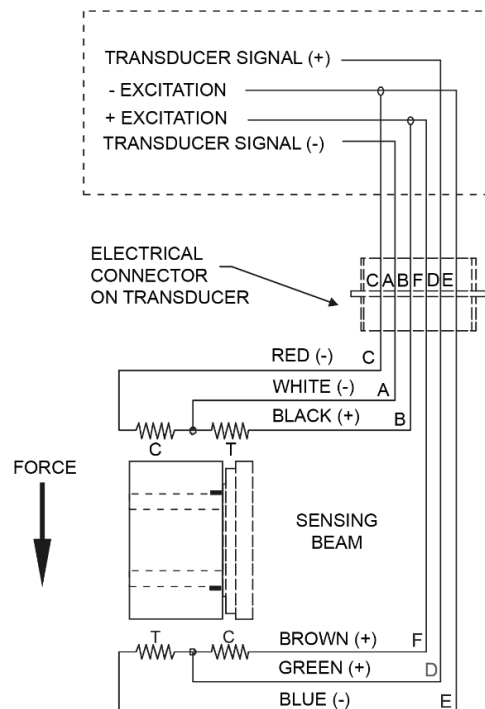

**Figure 6 - MODEL TW LOAD CELL WIRING**

The physical location of the strain gages, on opposite sides of the beam, ensures that each gage experiences the same temperature variations. This, and the Wheatstone bridge configuration, provides automatic temperature compensation and a stable output.

The strain gages used in the TW load cell are high output semiconductor devices with up to 33 times greater output than the less expensive foil gages used in some budget transducers. Therefore, the signal amplifier used with the TW load cell is a very stable, low-gain design. An added benefit of the high output is inherent immunity to electrical noise.

# 3 CALIBRATION AND SETUP

## 3.1 INTRODUCTION

No physical calibration adjustments are required with the TW load cell system. Follow the electronic calibration steps listed in the manual of the Tension Controller, Indicator or Amplifier being used with the device. Some general calibration instructions are listed below for reference.

## 3.2 ZERO THE TENSION METER

1. With no weight on the idler wheel and power connected to the devices, press the *Quik-Cal™ Zero* button on the supported amplifier or indicator. If using a touchscreen indicator or controller, press the **Zero** command at the touchscreen menu prompt.

## 3.3 CALIBRATE THE TENSION METER

1. See Figure 7. Pass the rope over the idler pulleys and under the load cell pulley (located in the center position). Anchor one end to a stationary object. Attach the calibration weight to the free end of the cord or rope and let it hang without touching anything.
2. **Wait for the weight to stop swinging.**
3. Press the **Calibrate** button on supported *Quik-Cal™* amplifiers and indicators or press the **Calibrate** command at the touchscreen menu prompt.
4. This concludes the *calibration procedure*.

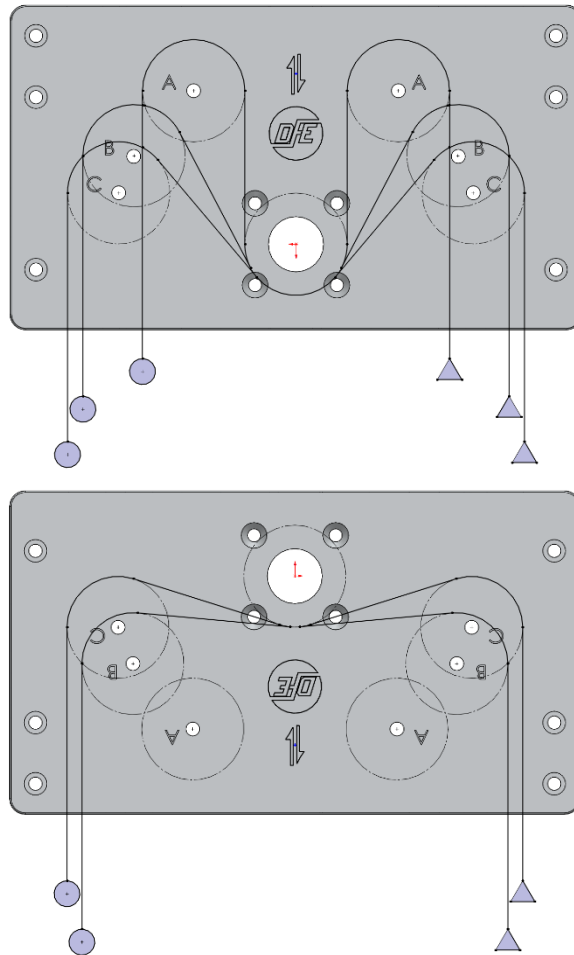

Figure 7 – CALIBRATION WEIGHT POSITION FOR EACH WEB PATH

## 4 CARE AND MAINTENANCE

---

Your Tri-Wheel™ Tension Load Cell has been manufactured of quality materials. With proper application and installation, your load cell system should be relatively maintenance-free and long-lasting. Any changes in your application which affect the dynamics of your equipment such as line speed, net force, material, cleanliness, etc., may require a change in load rating, pulley configuration or fixture relocation. Contact DFE for engineering review and assistance, if needed.

## 5 TROUBLESHOOTING

---

See the troubleshooting section at <https://www.dfe.com/products/tension-transducers/tri-wheel-tension-system/> for help resolving common setup or operational issues.

# TERMS AND CONDITIONS OF SALE AND SHIPMENT

---

See [www.dfe.com/terms-and-conditions/](http://www.dfe.com/terms-and-conditions/) for current Terms and Conditions.



307 PICKERING ROAD  
ROCHESTER, NEW HAMPSHIRE 03867-4630  
U.S.A

TEL: (603) 332-6150  
FAX: (603) 332-3758

E-mail: [info@dfe.com](mailto:info@dfe.com) Internet: <https://www.dfe.com/>

CANADA

EUROPE

MEXICO

UNITED KINGDOM

TAIWAN

KOREA

CHINA

INDIA

AUSTRALIA

SOUTH AFRICA

SOUTH AMERICA