



DOVER FLEXO ELECTRONICS, INC.
ISO 9001 CERTIFIED

INSTRUCTION MANUAL
MODEL NW TRANSDUCER

DOC 801-2252 R1

5 YEAR WARRANTY



307 Pickering Road

Rochester, NH 03867 U.S.A.

For assistance, please contact:

- TECHNICAL SERVICE** - Installations, Start-Up, Troubleshooting, Repairs, Field Service, Returns. **E-mail: techsupport@dfc.com**
- CUSTOMER SERVICE** - Replacement Parts, Individual Products, Questions about Orders, Manuals. **E-mail: customerservice@dfc.com**
- SALES** - Product Information, Systems Application Questions, Placing orders for standard products and special systems. **E-mail: customerservice@dfc.com**

Telephone: (603) 332-6150

Fax: (603) 332-3758

E-Mail : info@dfc.com Internet: www.dfc.com

TABLE OF CONTENTS

SECTION ONE	DESCRIPTION	PAGE
1.1	General Description	1
1.2	Construction and Mechanical Operation	1
1.3	Electrical Operation	2
1.4	Specifications	2
1.5	Features	3
1.6	Options	4
SECTION TWO	INSTALLATION	
2.1	Dimensions	5
2.2	Selection of Mounting Location	6
2.3	Installation instructions for Standard Transducer	7
2.4	Installation Instructions for IND Option	8
SECTION THREE	CALIBRATION AND SET-UP	
3.1	Introduction	9
3.2	Zero the Tension Meter	9
3.3	Calibration	9
3.4	Changing the Full Scale Tension Range	10
SECTION FOUR	CARE AND MAINTENANCE	11
SECTION FIVE	TROUBLESHOOTING	12
SECTION SIX	REPLACEMENT PARTS	14
APPENDICES:	A. Transducer Electrical Connections	15
	B. Load Rating Selection	16
	C. Typical Tensions	18
	Terms and Conditions	19
	Index	23

LIST OF ILLUSTRATIONS

FIGURE: 1.	Example of Strain Gage Connections	2
2.	NW Dimensions	5
3.	Dimensions of Amplifier Module (Ti26)	6
4.	Tension Zones	6
5.	NW Mounting Styles	7
6.	Orient the Transducer	7
7.	Amplifier Showing Adjustment Pots	9
8.	Web Path	10
9.	Model NW Transducer Wiring	15
10.	Load Rating Selection Formulas	16

1.1 GENERAL DESCRIPTION

The Model NW Narrow Web Tension Transducer is an electro-mechanical device that converts web tension into a D.C. voltage which is proportional to tension. The voltage is amplified in external electronic circuitry and displayed on an analog or digital meter which is calibrated to indicate actual web tension, expressed in pounds, ounces, grams, kilograms, newtons or any other desirable units. It can also be supplied to a regulator circuit to control tension automatically.

The Narrow Web Tension Transducer combines a bearing-mounted idler roll and two tension sensing elements in one package. Typically, it is used in tension control and display systems in label, tag, or tape printing or processing machines where the machine has only one side frame and the idler rolls are cantilevered.

The information in this Section will help give a clear understanding of the Model NW Transducer, how it works and how it is used.

1.2 CONSTRUCTION AND MECHANICAL OPERATION

The Narrow Web roll is manufactured to industry standards for Total Indicated Runout (TIR), surface finish and taper. Optional surface finishes such as hard coat anodized, grooved, or plasma coat, are also available.

The shaft is one piece stainless steel bolted into the aluminum shaft housing. Perpendicularity to the base of the shaft housing is maintained to within 0.005 inches per foot of shaft length.

The bearings are the self aligning ball type. Barriers are provided at the ends of the roll to discourage entrance of contamination. An extra-deep bearing bore on the connector end allows the roll to expand in length with rising temperature without causing any stress on the roll or bearings.

Inside the transducer are two dual cantilever beams, one at each end of the roll, with strain gages mounted on the top and bottom surfaces of each. The bearings are attached to the free end of each beam. When web tension is applied the beam deflects a small amount, causing an electrical output from the strain gages.

The shaft acts as a mechanical stop, preventing damage from accidental overloads. The stop is functional through 360 degrees, so the overload condition may occur from any direction, not just the load direction. In all cases, the beam is prevented from deflecting far enough to cause damage.

1.3 ELECTRICAL OPERATION (see figure 1)

The Model NW Transducer has two tension sensors, one inside each end of the transducer roll. Web tension exerts a force on the roll which is transmitted to the cantilever beams by the bearings. Two semiconductor strain gages are mounted on the beam, one on the top and one on the bottom. As force is applied and the beam deflects, the top gage is stretched and the bottom gage is compressed. This increases the electrical resistance of the top gage and decreases the resistance of the bottom gage. The gages on both beams are electrically connected together in a Wheatstone bridge configuration. The bridge produces double the output of a single beam and averages the outputs so web position, width and loose or tight edges do not affect the accuracy of the tension signal. **NOTE: Figure below is not actual wiring diagram, See Appendix A, page 15.**

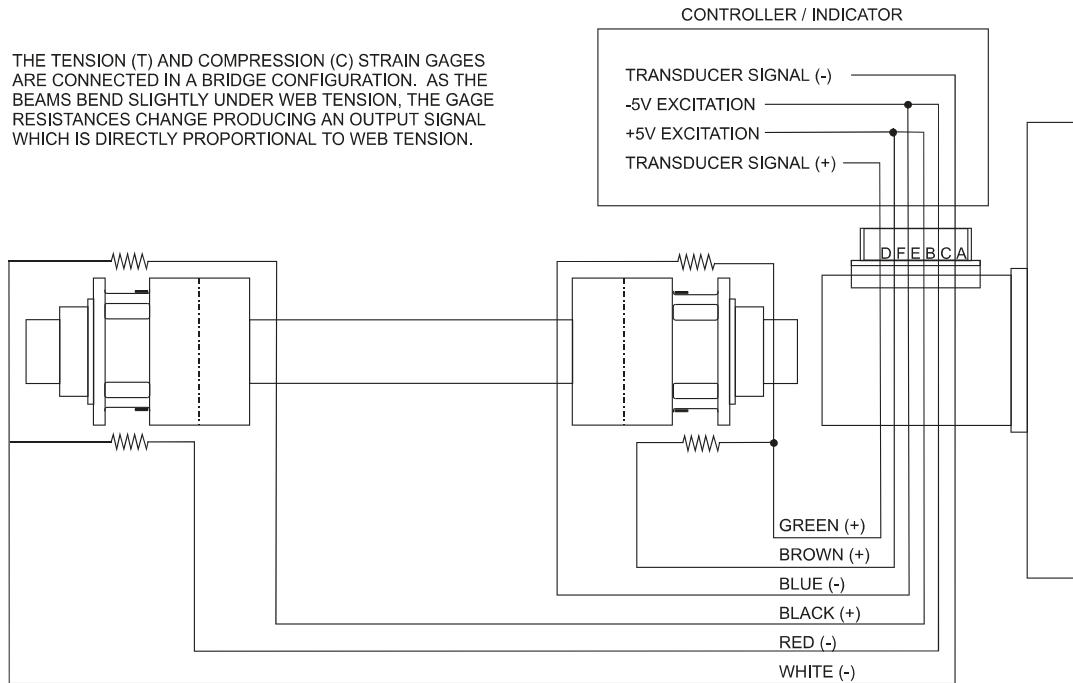

Figure 1 - EXAMPLE OF STRAIN GAGE CONNECTIONS

The physical location of the strain gages, on opposite sides of the beam, ensures that each gage experiences the same temperature variations. This, and the Wheatstone bridge configuration, provide automatic temperature compensation and a stable output.

The strain gages are high output semiconductor devices which typically have an output sixteen times greater than the inexpensive foil gages used in some transducers. Therefore, the signal amplifier used with these Model NW transducers is a very stable low-gain design. An added benefit of the high output is inherent immunity to electrical noise.

1.4 SPECIFICATIONS

ELECTRICAL

Excitation Voltage:	5 Vdc (10Vdc with XR option)
Output:	500mVdc, nominal (1 Vdc with XR option)
Input Voltage (IND option only):	24 Vdc
Gage Resistance	Half bridge at each end of idler roll. 100 Ohms, nominal, each gage.
Non-Repeatability:	± 1/4% FS, typical
Combined Non-Linearity and Hysteresis:	± 1/2% FS

1.4 SPECIFICATIONS *continued* . . .

ELECTRICAL

Temperature Range:

Std NW transducer	-10° F to 200° F (-23° C to 93° C)
NW with IND Option	40° F to 104° F (4° C to 40° C)
Temperature Coefficient:	0.02% per ° F, typical (0.036% per ° C)
Electrical Connector	ITT Cannon KPT02E10-6P
Mating Electrical Connector	ITT Cannon KPT06F10-6S
Electrical Connector Position:	Connector position is shown by looking at end of roll. Standard is 6 o'clock, same as load direction. Others are 12:00 and Rear (Rear connector position is for Flange mounting only).
Connector Pin Assignments:	Pin A = (-) output, white, Pin B = +5V, black, Pin C = -5V, red, Pin D = (+) output, green, Pin E = -5V, blue, Pin F = +5V, brown

MECHANICAL

Deflection of Sensor Beam:	0.016 inch typ. (0.41 mm)
Load Ratings:	12, 25, 50, 100 lbs. (53, 111, 222, 445 N)
Overload Rating:	400 lbs. (1779 N) minimum, in load direction, without damage
Std. Roll Widths:	6, 7, 8, 10, 12, 14, 16, 18, 20 inches (152, 178, 203, 254, 305, 356, 406, 457, 508 mm). 6" available only on Sizes 0 and 1. 7", 18", and 20" available on Size 2 only.
Display (IND option only):	Red LED, 3 digits, 0.56" character height
Orientation:	The transducer may be installed in any position
Roll: Material	6061 Aluminum
Balance	quality grade G2.5 per ISO 1940/1-1986 & ANSI S2.19-1989
Finish	32 microinch
Weights:	

Roll Weights (Aluminum)	6"	7"	8"	10"	12"	14"	16"	18"	20"	Bearing Assembly
NW0	lbs	0.84	1.15	1.45	1.76	2.06	2.37	0.25
	<i>kg</i>	0.38	0.52	0.66	0.80	0.94	1.07	0.11
NW1	lbs	1.63	2.23	2.83	3.43	4.03	4.64	1.0
	<i>kg</i>	0.74	1.01	1.28	1.56	1.83	2.10	0.45
NW2	lbs	1.3	1.6	2.2	2.6	3.1	3.5	4.0	4.4
	<i>kg</i>	0.59	0.73	1.0	1.18	1.41	1.59	1.81	2.0

Shaft and Shaft Housing: Stainless steel shaft and aluminum housing

1.5 FEATURES

Features of Standard Transducer

- Wide operating Tension range.
- Four standard load ratings.
- Nine roll widths up to 20 inches. Special widths available.
- Standard NW can be used with any standard Dover tension controller or indicator.
- Compact. Requires little space in the machine.

Features of Indicator Option

- 24Vdc Power Input.
- Zero, Cal, and Display Adjustments. Adjustment buttons accessible with bezel removed.
- Display can be rotated +/- 160-180 degrees on end of transducer.
- 0-10V Output. Amplifier module includes 0-10Vdc output with amphenol for external wiring. Mating connector not included.
- Full Scale Display. Displays scales from 1 lb. to 180 lbs.

1.6 OPTIONS

- **Extended Range (XR).** Allows twice the excitation of the transducers being used. Transducers must also have extended range.
- **Hard Coat (HC).** Black dye anodized hard coat.
- **Indicator Option (IND).** Tension display in end of roll with power input (24Vdc, user supplied) through amplifier module (TI26). Connect via cable (std.721-2542 is 5 ft, or specify length on 721-2541). This option is only available on the NW2 size 2 without Extended Range (XR) option. A **25% Calibration Weight (25CW)**, and **Din Rail Clip (DRC)** mounting option are available for the amplifier.
- **Metric Mount Stud (MMS).** Metric mounting screw for S type transducers.
- **Mounting Spacer (MS).** To extend the length of the unit.
- **Non-Lubricated Bearings (NLB).** No lubrication for bearings. For lowest drag torque. Voids warranty.
- **Oiled Bearings (OB).** Uses oil instead of grease for lubrication. For low drag torque. Voids warranty.
- **Steel Roll (SR).** Roll is made of steel, or **Stainless Steel Roll (SSR).** Roll is made of 304 stainless steel.

SECTION 2

INSTALLATION

2.1 DIMENSIONS

		A	B	C	D	E	F	G	J	K	L	N
NW0	IN	6-16	2.25	1.56	1.80	1.67	0.24	3.12	2.50	1/2-13	0.38	0.34
	MM	152/406	57.2	39.6	45.7	42.4	6.1	79.2	63.5	M12	9.7	8.64
NW1	IN	6-16	3.00	1.56	2.60	2.40	0.28	4.49	3.50	1/2-13	0.38	0.53
	MM	152/406	76.2	39.6	66.0	61.0	7.1	114	88.9	M12	9.7	13.5
NW2	IN	7-20	3.50	1.56	2.60	2.40	0.28	4.49	3.50	5/8-11	0.38	0.53
	MM	178/508	88.4	39.6	66	62.0	7.1	114	88.9	M16	9.7	13.5

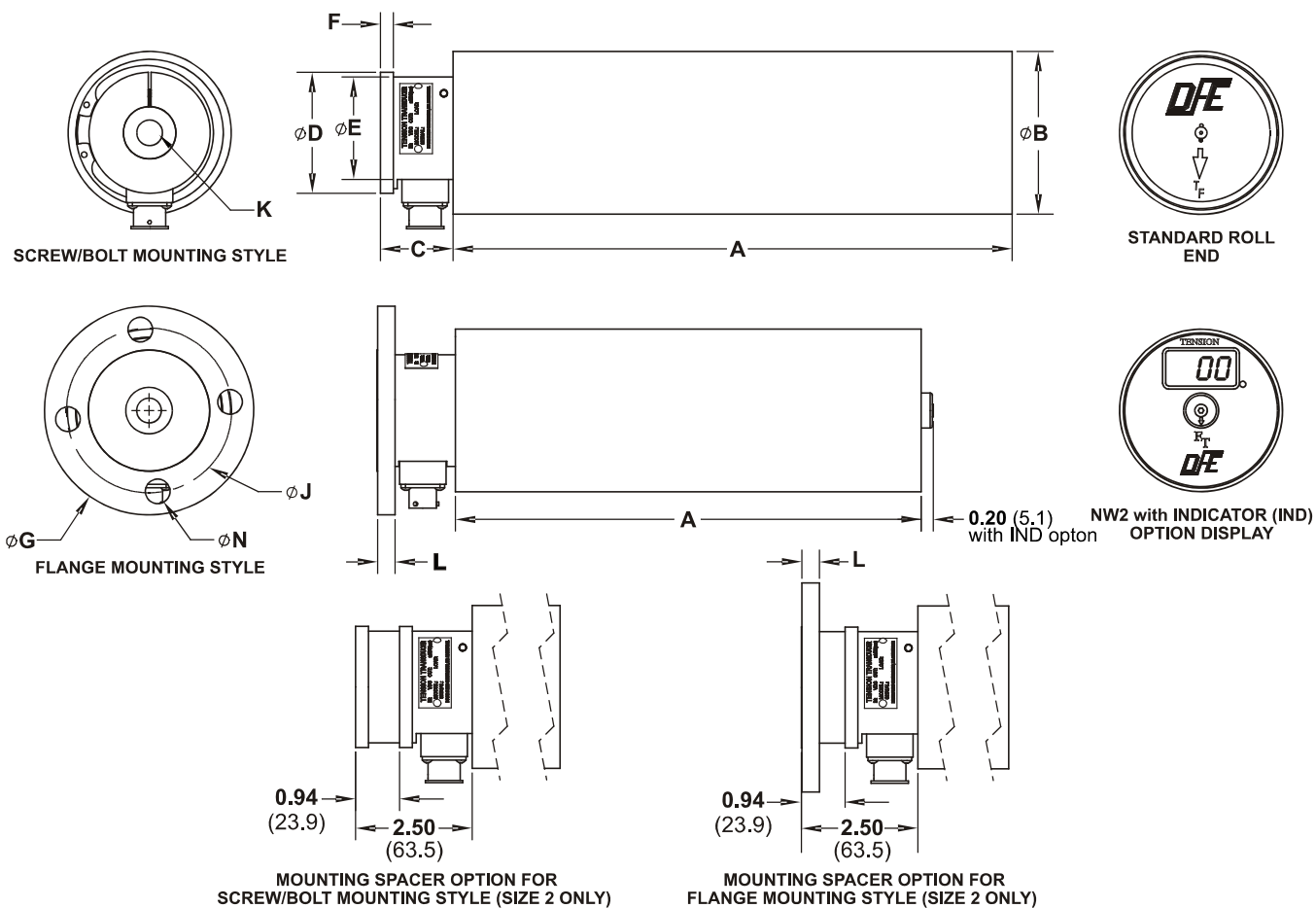

Figure 2 - NW TRANSDUCER DIMENSIONS

Ti26
(shown with DIN Rail Clip option)

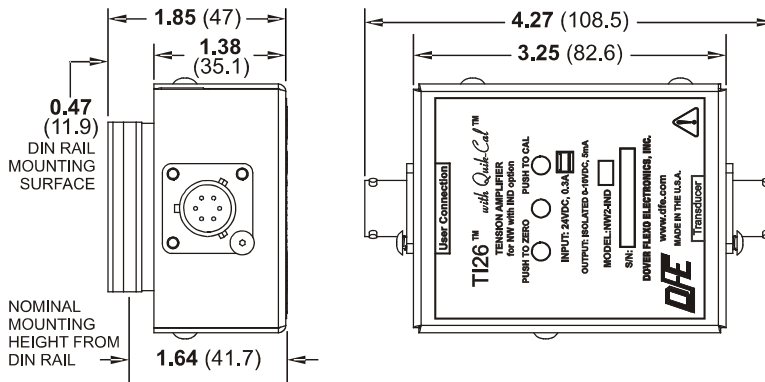

Figure 3 - DIMENSIONS OF AMPLIFIER MODULE (Ti26) FOR IND OPTION

2.2 SELECTION OF MOUNTING LOCATION

The following factors must be considered when installing your Narrow Web Transducer. Special references will be noted for the Indicator Option where applicable.

Please Note! There must be no brakes, clutches, belts, chains or gears attached to the transducer roll. It should not be used as a nip roll or be in contact with a nip roll. Nothing must contact the roll except the web.

1. TENSION ZONE.

The transducer must be located in the tension zone which is to be monitored or controlled. The beginning or end of any tension zone is always at a nip (driven or braked), unwind shaft, rewind shaft or drag bar. Any element in the web path that can change web tension is at one end of a tension zone.

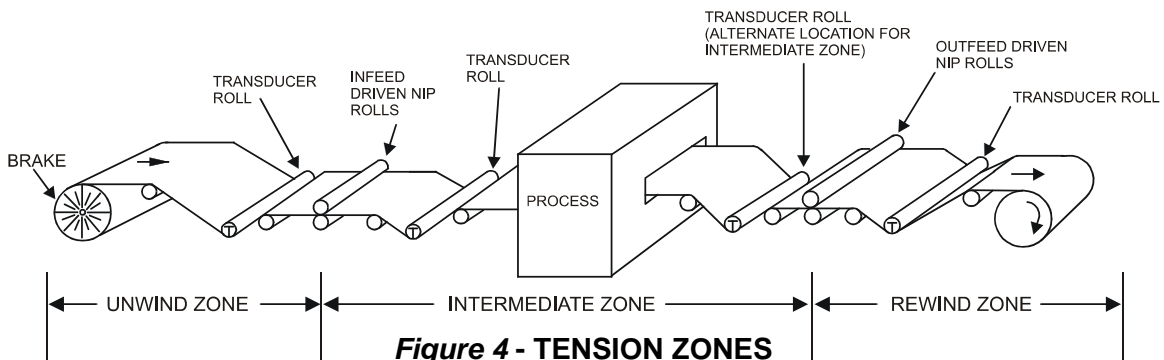

Figure 4 - TENSION ZONES

2. WRAP ANGLE.

The web must always contact the transducer roll in exactly the same way. The wrap angle must not change as the unwind or rewind roll diameter changes. Therefore there must be at least one idler roll between the transducer and the unwind or rewind shaft. If the machine has more than one webbing path, be sure to choose a location that is wrapped the same for each. Otherwise it will be necessary to install an additional transducer, or dual calibration circuitry, or both. If the wrap angle is allowed to change, the transducer output will change with angle as well as tension, and accuracy will be reduced.

3. MOUNTING SURFACE.

The structure on which the transducer is mounted **MUST** be strong. Any movement of the structure may cause the transducer to become mis-aligned. This probably will not affect the transducer's performance but it could cause the web to shift toward one side when it goes over the roll.

4. ROLL WIDTH. The face width of the roll is normally similar to the other rolls in the machine. Standard widths are specified in Section 1.4. If other widths are needed, consult Dover Flexo Electronics.

2.3 INSTALLATION INSTRUCTIONS FOR THE TRANSDUCER (including safety notes)

Warning! If this equipment is not installed or operated in the manner specified, the operating safety of the unit or of connected equipment cannot be guaranteed.

1. Mounting the standard transducer

The transducer is mounted on the machine frame by one of two methods; an S-mount which provides a tapped hole in the base of the shaft housing or by the use of the optional FL flange mount which provides a 4-hole pattern for bolting to the side frame.

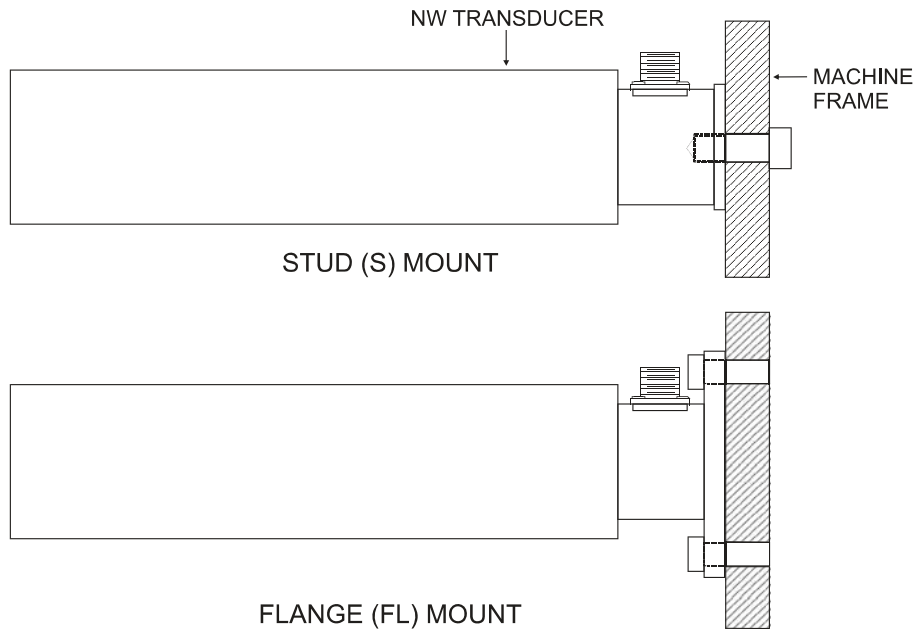

Figure 5 - NARROW WEB TRANSDUCER MOUNTING STYLES

The transducer must be turned so the Tension Force arrow points in the same direction as the Tension Force. Tighten the mounting bolt(s) so it cannot turn. See Figure 6 below.

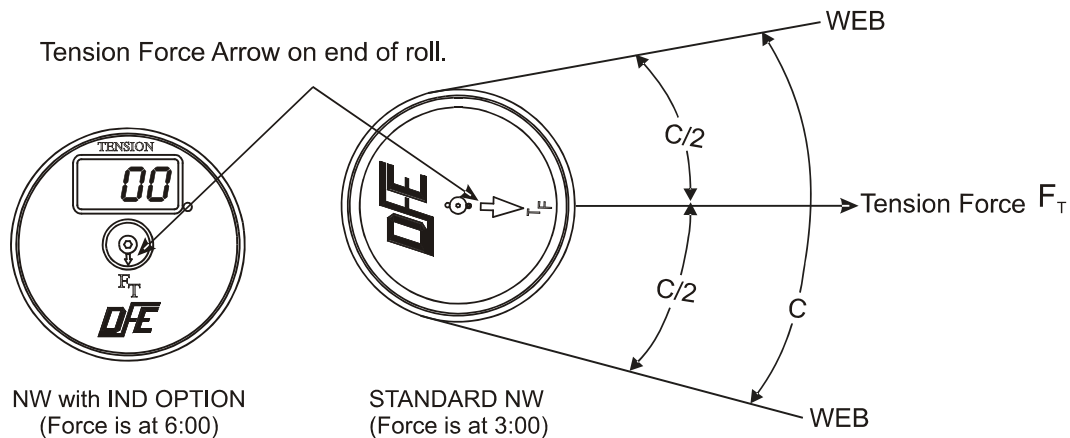

Figure 6 - ORIENT THE TRANSDUCER

2. Connect Transducer to Electronics

Make your connections to your electronics by plugging in the cables, being careful to align the connectors properly - never force them together. Tighten the connectors to properly seat the pins.

If you have just the standard NW Transducer you may go to Section 3 for calibration.

2.4 INSTALLATION INSTRUCTIONS FOR THE INDICATOR OPTION POWER SUPPLY

1. Using the cable supplied, find the end of the transducer cable marked “G” and connect to the transducer connector on the amplifier module. String your cable to the transducer and connect it. To connect to the amplifier, use purchased cables (DFE#721-2542 or 721-2541) or a ITT Cannon KPT06F10-6S amphenol type bayonet connector and connect as follows:

		DFE SUPPLIED CABLE
Pin A	+24 Vdc	White Wire
Pin B	PWR Return for 24 Vdc	Black Wire
Pin C	Not Used	Red wire
Pin D	0-1mA Isolated out (Meter)	Green Wire
Pin E	0-10Vdc	Blue wire
Pin F	Isolated Return	Brown wire
Case	Earth Ground	Shield wire

! CAUTION: Case should be grounded to earth ground to avoid interference from other electrical equipment.

2. Attach amplifier to frame or wire-way, or use the DIN Rail Clip option.
3. Calibrate the amplifier according to the procedure found in Section 3.

3.1 INTRODUCTION

Unless you have purchased the NW with Indicator Option, there are no calibration adjustments on the Model NW Transducer itself. The instructions below are for the electronic device which the transducer is connected to. All of the following terminology and procedures assume that the transducer is connected to a **Dover Flexo Electronics** tension controller, tension indicator, or has its own indicator option. If some other device is being used, you should follow the instructions furnished with it.

These are general instructions which are correct for most **Dover** controllers and indicators, and are placed here for your convenience. If you have any difficulty calibrating or if there is any discrepancy between these instructions and those in the Instruction Manual for the indicator or controller, you should disregard these instructions and follow the instructions in the Manual for the indicator or controller.

The transducer must be properly installed and oriented as directed in **SECTION 2**.

3.2 ZERO THE TENSION METER

You will need to know the maximum tension this system was designed to measure. This information should be available from the people who ordered the system. If you cannot locate the information, call Dover Flexo Electronics at (603) 332-6150 to obtain it.

1. **For Standard NW:** Turn the POWER OFF. If the meter does not read zero, turn the mechanical adjustment screw on the meter face so the needle indicates zero tension.

For NW with IND Option: The display on the NW IND option has been zeroed at the factory. No further adjustment is necessary.

3.3 CALIBRATE THE IND OPTION OUTPUT FOR ACCURACY

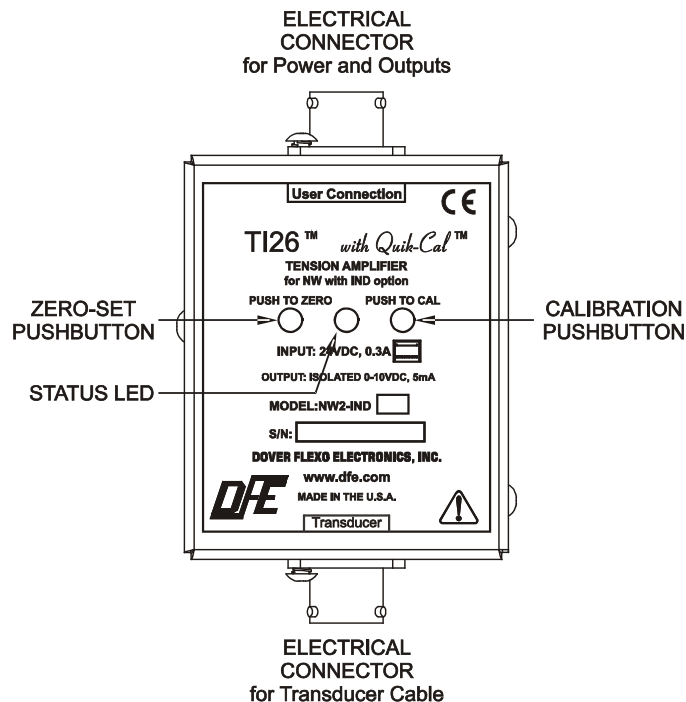

Figure 7 - AMPLIFIER (Ti26) SHOWING ADJUSTMENTS

Find an object of some kind that weighs 10% of the maximum value on the tension meter scale (25% CW optional). A spring scale can also be used. Get a length of rope, wire, or cable about 15 feet (3 meters) long.

1. **ZERO:** Ensure nothing is hanging on or pressing on the transducer roll (including the calibration rope). Press and hold the ZERO pushbutton on the unit front panel for at least 1 second. The unit will automatically adjust and store the tension-zero value one second after the button is pressed. The unit will flash the green status LED (located between buttons on product face) once to indicate the zero has been stored. Release the button. The output will read 0 Vdc. The tension meter (if attached) will read zero.
2. **CALIBRATION:** Fasten one end of the rope in the machine and thread the other end around the transducer roll in exactly the same path the web will take. Ideally the rope should hit an idler roll immediately before and after the tension sensing roll. It does not have to pass over any other rollers once these three are strung. Refer to Figure 8.
 1. Attach the weight to the free end of the rope as shown in Figure 8. The weight should not touch anything. Wait for the weight to stop swinging. Ideally, the rope will pass over the center of the transducer roll.

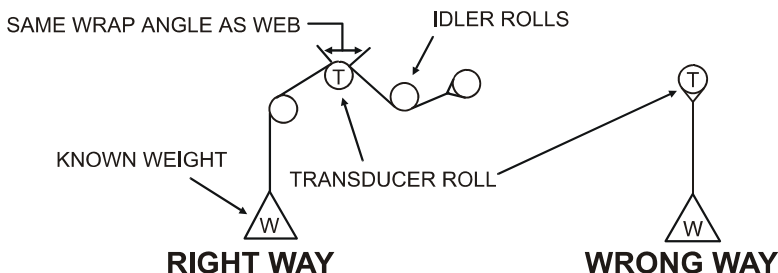

Figure 8 - WEB PATH

2. Press and hold the CAL pushbutton on the unit front panel for at least 1 second. The unit will store the calibration information one second after the button is pressed. The unit will flash the green LED (located between buttons on product face) once to indicate the calibration has been stored. The output will read 1.0 Vdc after pressing calibration. The meter will read 10% of full scale.
3. Remove the weight and observe the output. It should read 0 Vdc with nothing touching the tension sensing roller.

3.4 CHANGING THE FULL SCALE TENSION RANGE (NW with IND Option only)

The Digital Meter should have been adjusted at the factory to accommodate the expected maximum tension. THEREFORE, NO CHANGES SHOULD BE NEEDED. However if an update must occur, please refer to the 3 Digit Digital Meter Option Insert #801-2303 for instructions.

Your Dover Flexo Narrow Web Tension Transducer has been manufactured of quality materials. With proper application and installation your transducer will be maintenance free for years and long lasting. Any changes in your application which affect the dynamics of your equipment such as web speed, net force, material, etc. could possibly require upgrading of load rating or roll change. Contact Dover for specific information and engineering approval.

The NW Transducer with Indicator option will indicate tension in your system without any further operator intervention as well. It is not necessary to perform any type of maintenance on the indicator. However, you may find it worthwhile to observe whether there is a buildup of dust, debris, or moisture on or near the unit after a period of time.

For IND Option: Periodic calibration will insure output remains correct. Simply observe the unit after the web is removed to verify that it reads zero. A minus sign (-) may flicker on and off. If zero is correct, calibration is generally not required.

Higher confidence may be achieved by hanging a weight. See Calibration in Section 3 for details. If hanging weight shows correct tension, calibration is accurate.

If output is incorrect, perform full zero and calibration procedure. If output is correct, unit is functioning properly.

This is a list of problems which could occur during initial start-up or afterwards. The probable causes are listed with the most likely one first and the least likely one last. Call our **TECHNICAL SERVICE DEPARTMENT** for analysis of operating conditions and solution to problem.

1. TRANSDUCER ROLL SHAKES, VIBRATES, or BOUNCES

- a. Transducer mounting bolts are not tight.
- b. Roll is turning at its natural frequency.

2. CAN NOT ADJUST TENSION METER TO READ ZERO WHEN WEB IS SLACK

- a. Failure in the tension indicator circuit
- b. Strain gage failure

3. TENSION METER READS BACKWARDS

- a. Transducers are installed backwards with force arrow pointing in opposite direction.
- b. Transducer cables are connected wrong at controller/indicator terminal strip. Signal wires are reversed.

4. TENSION METER NEEDLE PEGS HIGH OR LOW

- a. Meter is not electrically adjusted to zero.
- b. Transducer cable has broken wire, poor connection or short circuit.
- c. A strain gage has failed. To verify: Unplug the transducer cable and use an ohm-meter to measure the resistance of the gages at the connector on the transducer. Measure between pins A,B, and A,C. In each case, the resistance should be about 100 ohms. Measure the resistance between any pin and the outside of the transducer. The meter should read infinite resistance. Apply a force to the roll by hand or by using a rope and a weight, in the direction of the tension force and maintain it while again measuring between pins A,B and A,C. The resistance should be only a few ohms different from before.
- d. Failure in the tension amplifier circuit of the controller/indicator.

5. TENSION METER DOES NOT READ ZERO WHEN WEB IS SLACK AND READING DRIFTS WITH TIME.

- a. Meter is not calibrated.
- b. Transducer cable has a broken wire, poor connection or short circuit.
- c. A strain gage is cracked. Perform the test in 4c above, or 8c if IND option is installed.

6. TENSION METER DOES NOT READ THE SAME EACH TIME THE SAME FORCE IS APPLIED (poor repeatability)

- a. Extreme build-up of dirt, ink, adhesive, grease or other foreign material inside end of roll causing interference with beam movement.
- b. Transducer cable has a broken wire, poor connection or short circuit.
- c. A strain gage is cracked. Perform the test in 4c above, or 8c if IND option is installed.

7. TENSION METER READING DOES NOT CHANGE WHEN FORCE IS APPLIED TO ROLL. METER READS ZERO.

- a. Meter is not calibrated.
- b. Extreme build-up of dirt, ink, adhesive, grease or other foreign material inside end of roll causing interference with beam movement.
- c. Transducer cable has a broken wire, poor connection or short circuit.
- d. Transducer cables connected incorrectly, or to wrong transducers.
- e. Failure of tension amplifier circuit in controller/indicator. Unit not turned on.

8. IND OPTION FLASHES OR READS MINUS SIGN (-) CONSTANTLY.

- a. System has not been properly calibrated.
- b. Broken wire between NW and amplifier unit.
- c. Strain gauge failed. To verify: Unplug the transducer cable and use an ohm-meter to measure the resistance of the gages at the connector on the transducer. Measure between pins A and B, then B and D. In each case, the resistance should be about 50 ohms. Measure the resistance between any pin and the outside of the transducer. The meter should read infinite resistance. Apply a force to the roll by hand or by using a rope and a weight, in the direction of the tension force and maintain it while again measuring between pins A and B, then B and D. The resistance should be only a few ohms different from before.
- d. Failure in the amplifier module.
- e. Failure in the display module.

SECTION 6

REPLACEMENT PARTS

(DFE P/N)

NW Transducer Parts:	SIZE 0	SIZE 1	SIZE 2
Electrical Connector, KPT02E10-6P	106-0049		
Electrical Connector Screws: M3 x 0.5 x 20 Black Oxide	123-0408		
Transducer cable, 15 ft. (Std.)	721-1558		
Transducer Cable, 20 ft. (Accessory)	721-1551		
Transducer Cable, 25 ft. (Accessory)	721-1552		
Transducer Cable, 30 ft. (Accessory)	721-1553		
Transducer Cable, Special Length request	721-0964		
NW Indicator Option Parts:	SIZE 2 ONLY		
Transducer to Amplifier Interconnect Cable, 5 ft.	721-2542		
Transducer to Amplifier Interconnect Cable, Special length request, 25 ft. max.	721-2541		

Call **Customer Service** for prices and for part numbers of items not listed. For help with service or repairs, call **Technical Service**. We can be reached by the following:

Phone: 603-332-6150

Fax: 603-332-3758

E-mail: Customer Service: customerservice@dfc.com

Technical Service: techsupport@dfc.com

NARROW WEB (NW) TRANSDUCERS

The tension (T) and compression (C) strain gages are connected in a bridge configuration. As the beams bend slightly under web tension, the gage resistances change producing an output signal which is directly proportional to the web tension.

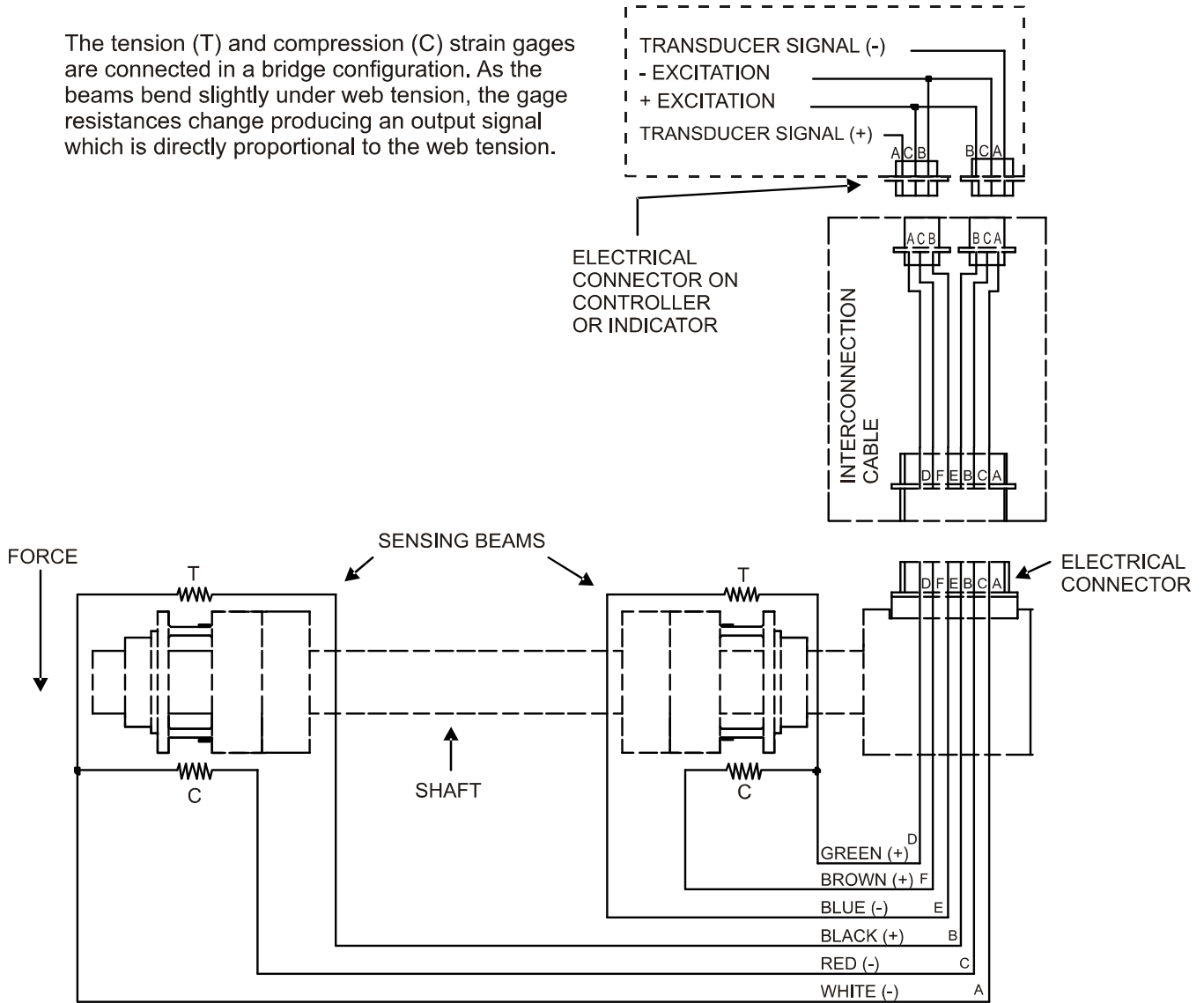

Figure 9 - MODEL NW TRANSDUCER WIRING

Following is the procedure used to calculate the load rating for the transducer(s) for your application. The correct transducer load rating was determined by maximum web tension, wrap angle, and roll weight. If you change any part of your application or plan to move your transducers to another application, please follow the steps below to reconfigure. As always please feel free to contact one of our Applications Engineers for assistance .

1. LOAD RATINGS

The Model NW Transducer is available with four standard load ratings ranging 12 lbs. to 100 lbs. (53 to 445 N). Load ratings are generally selected for the application prior to purchase of the equipment. If more equipment is needed for a different application or a change to the present one, use the steps following to select the load ratings.

The correct transducer load rating for your application is determined by maximum web tension, wrap angle, and roll weight. Choose the appropriate wrap configuration from the diagrams below. Then compute the Net Force using the formula below the diagram.

2. SELECTION PROCEDURE

The correct load rating is found in four simple steps:

Step 1. OBTAIN DATA TO PLUG INTO THE SELECTION FORMULA

- Estimate the maximum web tension. Use the Typical Tensions table in Appendix D as a guide if necessary.
- Determine the wrap angle.
- Determine the angle of tension force F_T , relative to the vertical. (Note: F_T bisects wrap angle B)

Step 2. COMPUTE NET FORCE USING THE SELECTION FORMULA

Compute the Net Force, using the formula below the correct wrap diagram in Figure 20 below.

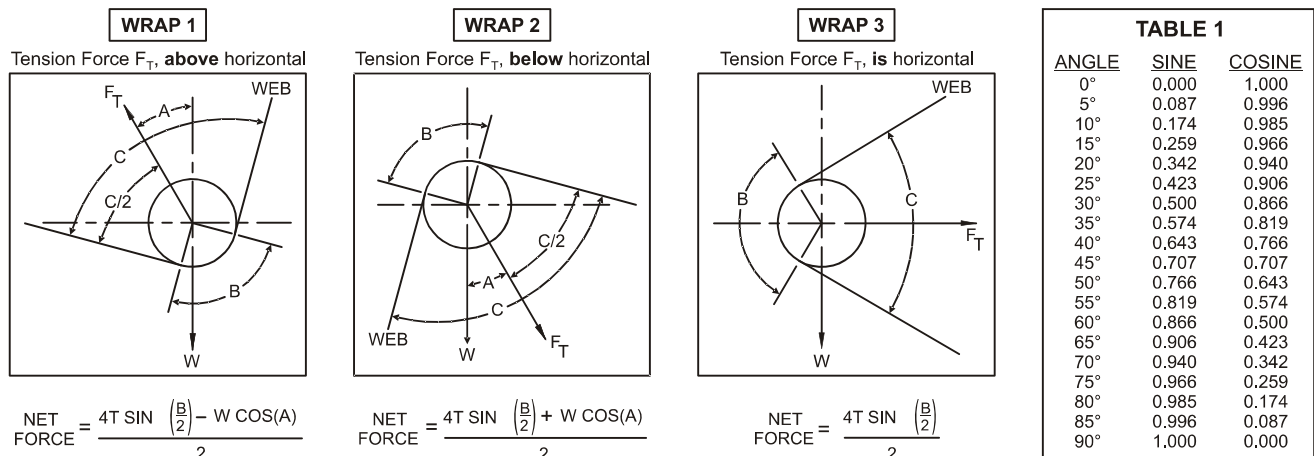

W = idler roll weight (See Note 1), T = Maximum web tension, B = Wrap angle = $180^\circ - C^\circ$, A = Angle between Tension Force F_T and vertical

Note 1: Roll weight equals weight of roll shell plus weight of bearing assemblies. Use chart below

Roll Weights (Aluminum)	6"	7"	8"	10"	12"	14"	16"	18"	20"	Bearing Assembly
NW0	lbs	0.84	1.15	1.45	1.76	2.06	2.37	0.25
	kg	0.38	0.52	0.66	0.80	0.94	1.08	0.11
NW1	lbs	1.63	2.23	2.83	3.43	4.03	4.64	1.0
	kg	0.74	1.01	1.28	1.56	1.83	2.10	0.45
NW2	lbs	1.3	1.6	2.2	2.6	3.1	3.5	4.0	4.4
	kg	0.59	0.73	1.0	1.18	1.41	1.59	1.82	2.0

Figure 10 - LOAD RATING SELECTION FORMULA

Step 3. SELECT THE LOAD RATING

Use the chart below to select the correct load rating. In some cases, the load rating may be **LESS** than the computed Net Force. This is acceptable because the Net Force formula contains an oversizing factor of 2. Therefore the actual force exerted on the transducer will not exceed its rating,

LOAD RATING CHART	
NET FORCE -lbs. (N)	LOAD RATING - lbs. (N)
up to 15 (66)	12 (55)
16 - 32 (71-142)	25 (110)
33 - 63 (146-280)	50 (225)
64 - 125 (284-556)	100 (450)

Step 4: COMPARE LOAD RATING WITH EFFECTIVE TRANSDUCER ROLL WEIGHT

The following applies only to steel rolls and rolls in excess of 20 inches (508 mm) in width:

Sometimes a roll is so heavy that its weight uses up most of the operating range of the transducer. When this happens, it may not be possible to adjust the tension indicating meter to read zero when tension is zero because the adjustment range of the electronic circuit has been exceeded. To find out if the roll is too heavy, compare the load rating with the effective weight of the roll as follows: The effective roll weight is the "W COS (A)" term in the formula. If W COS (A) is more than 95% of the load rating chosen, the tension meter will probably not be adjustable to zero. If this is the case, one or more of the following changes must be made to reduce W COS (A) to less than 95% of the load rating:

1. Reduce the transducer roll weight,
2. Increase angle (A),
3. Use the next higher load rating (this is the least desirable choice because it reduces transducer signal output).

Appendix C:

Typical Tensions for Various Materials

TYPICAL TENSIONS FOR WEB MATERIALS

ACETATE	0.5 lb. per mil per inch of width		
FOIL	Aluminum	0.5 lb. per mil per inch of width	
	Copper	0.5 lb. "	
CELLOPHANE	0.75 lb. per mil per inch of width		
NYLON	0.25 lb. per mil per inch of width		
PAPER 15 lb *	0.4 lb. per inch of width		
	20 lb	0.5 lb. "	
	30 lb	0.75 lb. "	
	40 lb	1.25 lb. "	
	60 lb	2.0 lb. "	
	80 lb	3.0 lb. "	
	100 lb	4.0 lb. "	
* based on 3000 sq. ft. ream			
PAPERBOARD 8pt	3.0 lb. per inch of width		
	12pt	4.0 lb. "	
	15pt	4.5 lb. "	
	20pt	5.5 lb. "	
	25pt	6.5 lb. "	
	30pt	8.0 lb. "	
POLYETHYLENE	0.12 lb. per mil per inch of width		
POLYESTER (Mylar)	0.75 lb. per mil per inch of width		
POLYPROPYLENE	0.25 lb. per mil per inch of width		
POLYSTYRENE	1.0 lb. per mil per inch of width		
RUBBER	<u>GAUGE</u>	<u>AT 25% STRETCH</u>	<u>AT 50% STRETCH</u>
	10 mil	1.75	3.68
	12 mil	1.10	2.03
	16.5 mil	4.09	8.17
	26 mil	2.47	4.97
SARAN	0.15 lb per mil per inch of width		
STEEL	<u>GAUGE - INS</u>	<u>UNWIND-PSI</u>	<u>REWIND-PSI</u>
	.001 -.005	1000	4000
	.006 -.025	850	3500
	.026 -.040	750	3000
	.041 -.055	650	2600
	.058 -.070	550	2200
	.071 -.090	450	1800
	.091 -.120	450	1400
	.121 -.140	400	1200
	.141 -.165	400	1000
	.166 -.200	400	900
	.201 -.275	400	800
	.276 -.380	300	700
VINYL	0.05 lb. per mil per inch of width		

*** For laminated webs, sum the tension for the individual webs and add 0.1 lb per inch of width.

TERMS AND CONDITIONS OF SALE AND SHIPMENT

1. THE COMPANY

Dover Flexo Electronics, Inc. is hereinafter referred to as the Company.

2. CONFLICTING OR MODIFYING TERMS

No modification of, additions to or conflicting provisions to these terms and conditions of sale and shipment, whether oral or written, incorporated into Buyer's order or other communications are binding upon the Company unless specifically agreed to by the Company in writing and signed by an officer of the Company. Failure of the Company to object to such additions, conflicts or modifications shall not be construed as a waiver of these terms and conditions nor an acceptance of any such provisions.

3. GOVERNING LAW

This contract shall be governed by and construed according to the laws of the state of New Hampshire, U.S.A. The parties agree that any and all legal proceedings pursuant to this contract shall take place under the jurisdiction of the courts of the State of New Hampshire in the judicial district of Strafford County.

4. PENALTY CLAUSES

Penalty clauses of any kind contained in orders, agreements or any other type of communication are not binding on the Company unless agreed to by an officer of the Company in writing.

5. WARRANTY

Dover Flexo Electronics, Inc. warrants, to the original Buyer, its' products to be free of defects in material and workmanship for five years from date of original shipment. Repairs on products are warranted for 90 days from date of shipment. During the warranty period the Company will repair or replace defective products free of charge if such products are returned with all shipping charges prepaid and if, upon examination, the product is shown to be defective. This warranty shall not apply to products damaged by abuse, neglect, accident, modification, alteration or mis-use. Normal wear is not warranted. All repairs and replacements under the provisions of this warranty shall be made at Dover Flexo Electronics or at an authorized repair facility. The Company shall not be liable for expenses incurred to repair or replace defective products at any other location or by unauthorized persons or agents. This warranty contains all of the obligations and warranties of the Company. There are no other warranties, either expressed or implied. No warranty is given regarding merchantability or suitability for any particular purpose. The Company shall not be liable in either equity or law for consequential damages, losses or expenses incurred by use of or inability to use its' products or for claims arising from same. No warranty is given for products of other manufacturers even though the Company may provide these products with its' own or by themselves. The provisions of this warranty can not be changed in any way by any agent or employee of the Company. Notice of defects must be received within the warranty period or the warranty is void. The warranty is void if the serial number tag is missing or not readable.

6. PAYMENTS

Standard terms of credit are net 30 days from date of shipment, providing satisfactory credit is established with the Company. Amounts past due are subject to a service charge of 1.5% per month or portion thereof or 18% per annum. The Company reserves the right to submit any unpaid late invoices to a third party for collection and Buyer shall pay all reasonable costs of such collection in addition to the invoice amount. All quoted prices and payments shall be in U.S. Dollars.

If the Company judges that the financial condition or payment practices of the Buyer does not justify shipment under the standard terms or the terms originally specified, the Company may require full or partial payment in advance or upon delivery. The Company reserves the right to make collection on any terms approved in writing by the Company's Finance Department. Each shipment shall be considered a separate and independent transaction and payment therefore shall be made accordingly. If the work covered by the purchase order is delayed by the Buyer, upon demand by Company payments shall be made on the purchase price based upon percentage of completion.

7. TAXES

Any tax, duty, custom, fee or any other charge of any nature whatsoever imposed by any governmental authority on or measured by any transaction between the Company and the Buyer shall be paid by the Buyer in addition to the prices quoted or invoiced.

8. RETURNS

Written authorization must be obtained from the Company's factory before returning any material for which the original Buyer expects credit, exchange, or repairs under the Warranty. Returned material (except exchanges or repairs under the Warranty) shall be subject to a minimum re-stocking charge of 15%. Non-standard material or other material provided specially to the Buyer's specification shall not be returnable for any reason. All material returned, for whatever reason, shall be sent with all freight charges prepaid by the Buyer.

9. SHIPPING METHOD AND CHARGES

All prices quoted are EXW the Company's factory. The Company shall select the freight carrier, method and routing. Shipping charges are prepaid and added to the invoice of Buyers with approved credit, however the Company reserves the right to ship freight-collect if it prefers. Shipping charges will include a charge for packaging. Company will pay standard ground freight charges for items being returned to Buyer which are repaired or replaced under the Warranty. Claims of items missing from a shipment must be received, in writing, within 30 days of original shipment

10. CANCELLATION, CHANGES, RESCHEDULING

Buyer shall reimburse Company for costs incurred for any item on order with the Company which is cancelled by the Buyer. Costs shall be determined by common and accepted accounting practices. A one-time hold on any item ordered from the Company shall be allowed for a maximum of 30 days. After 30 days, or upon notice of a second hold, Company shall have the right to cancel the order and issue the appropriate cancellation charges which shall be paid by Buyer. Items held for the Buyer shall be at the risk and expense of the Buyer unless otherwise agreed upon in writing. Company reserves the right to dispose of cancelled material as it sees fit without any obligation to Buyer. If Buyer makes, or causes to make, any change to an order the Company reserves the right to change the price accordingly.

11. PRICES

Prices published in price lists, catalogs or elsewhere are subject to change without notice and without obligation. Written quoted prices are valid for thirty days only.

12. EXPORT SHIPMENTS

Payment for shipments to countries other than the U.S.A. and Canada or to authorized distributors shall be secured by cash in advance or an irrevocable credit instrument approved by an officer of the Company. An additional charge will apply to any letter of credit. There will also be an extra charge for packaging and documentation.

13. CONDITION OF EQUIPMENT

Buyer shall keep products in good repair and shall be responsible for same until the full purchase price has been paid.

14. OWNERSHIP

Products sold are to remain the property of the Company until full payment of the purchase price is made.

DECLARATION OF CONFORMITY

We,

Dover Flexo Electronics
217 Pickering Road
Rochester, NH 03867 USA
Tel: (603) 332-6150
Fax: (603) 332-3758

declare under our sole responsibility that the product:

Model NW Web Tension Transducer,

manufactured after the date 1 May 1997, and to which this declaration relates, is in conformity with the following standards or other normative documents:

EN 55011: Radiated and Conducted Emissions
EN 50082-2: Electromagnetic compatibility - Generic immunity standard,
Part 2. Industrial Environment, to include:
ENV 50140: Radio Frequency Immunity - AM
ENV 50141: Conducted Radio Frequency Interference
ENV 50204: Radio Frequency Immunity - Pulse Modulated
ENV 61000-4-2: Electrostatic Discharge
EN 61000-4-4: Electrical Fast Transient Bursts

following the provisions of Council Directive 89/336/EEC of 3 May 1989 on the approximation of the laws of the member states relating to electromagnetic compatibility (the "EMC Directive").

The Technical Construction File is maintained at:

Dover Flexo Electronics
217 Pickering Road
Rochester, NH 03867 USA

Per Annex II R of the Machinery Directive (89/392/EEC):

The machinery, product, assembly, or sub-assembly covered by this Declaration of Conformity must not be put into service until the machinery into which it is to be incorporated has been declared in conformity with the provisions of the applicable Directive(s).

Date of issue: 5 May, 1997

Place of issue: Rochester, NH USA

Signed: _____

Alan H. Wysocki

Alan H. Wysocki, Engineering Manager

8010718a.doc

NOTES

NOTES

INDEX

Balance	3	Net Force	16
Beam	1, 2, 3, 5	Options	4
Bearing	1	Output	2
options	4	Overload	
part number	18	rating	3
specifications	3	stop	1
Breakaway torque	2-3		
		Parts, replacement	14
Cables		Repeatability	3
connectors/pins	2, 3, 8, 9	Replacement Parts	14
replacement	14	Roll Shell	
Calibration	9-10	material	3
Construction	1	weights	3, 21
		widths	3, 16
Deflection	1, 3	Specifications	2-3
Description	1	Standard Features	3
Dimensions	5-6	Stop (see Overload stop)	
		Strain gage	1, 3
Electrical connections	3, 8, 15	Surface finish	3
Electrical connector	2, 3		
environmental	4	Temperature	
mating connector part number	3, 18	coefficient	3
positions available	3	range	3
Electrical Operation	2	Tension force	7, 16
Excitation voltage	2	Tensions, typical	8
Extended Range	4	Tension zones	6
		Terms and Conditions of Sale	19
F_T (see Tension force)		Transducer location	6
FL (see Mounting style)		Troubleshooting	12-13
Features	3	Warranty	19
		Web path	10
Gage (see Strain gage)		Wheatstone bridge	2
		Wrap angle	16
Hard Coat	4	Zero	9
Hysteresis	2		
Installation	5-8		
Linearity	2		
Load rating	3		
selection of	16-17		
Mechanical Operation	1		
Material	3		
Mounting			
location	6		
styles	7		
surface	7		



307 PICKERING ROAD
ROCHESTER, NEW HAMPSHIRE 03867-4630 U.S.A
TEL: 603-332-6150
FAX: 603-332-3758
E-MAIL: info@dfc.com Internet: www.dfc.com

CANADA

MEXICO

UNITED KINGDOM

EUROPE

TAIWAN

KOREA

AUSTRALIA

COLOMBIA

INDIA

SOUTH AFRICA

CHINA