



INSTRUCTION MANUAL

Model SUPB Tension Transducers

DOC 801-0906

217 Pickering Road
Rochester, NH 03867 U.S.A.

For assistance, please call:

TECHNICAL SERVICE - Installations, Start-Up, Troubleshooting, Repairs, Field Service, Returns.

CUSTOMER SERVICE - Replacement Parts, Individual Products, Questions about Orders, Manuals.

SALES - Product Information, Systems Application Questions, Placing orders for standard products and special systems.

Telephone: 603-332-6150
Fax: 603-332-3758

E-mail: info@dfc.com Internet: www.dfc.com

©2001 Dover Flexo Electronics, Inc. All rights reserved.

Dover Flexo Electronics has made reasonable effort to ensure accuracy of this document. However NO WARRANTY, whether expressed or implied, is given regarding the completeness or correctness of information in this document. Dover Flexo Electronics shall not be liable for damages of any kind arising from the use or misuse of this document. Dover Flexo Electronics reserves the right to make changes, additions, and deletions to this document without notice and without obligation.

TABLE OF CONTENTS

SECTION ONE	DESCRIPTION AND OPERATION	PAGE
1.1	General Description	1
1.2	Construction and Mechanical Operation	1
1.3	Electrical Operation	2
1.4	Specifications	3
1.4	Standard Features	3
1.5	Options	3
SECTION TWO	INSTALLATION	
2.1	Dimensions	4
2.2	Pre-Installation Requirements	5
2.3	Selection of Load Rating	6
2.4	Installing the Transducers	9
SECTION THREE	CALIBRATION AND SETUP	
3.1	Introduction	11
3.2	Connection to the Electronics	11
3.3	Zero the Tension Meter	12
3.4	Calibrate the Tension Meter	12
SECTION FOUR	CARE AND MAINTENANCE	13
SECTION FIVE	TROUBLESHOOTING GUIDE	14
SECTION SIX	REPLACEMENT PARTS	16
APPENDIX A:	Transducer Electrical Connections	17
APPENDIX B:	Typical Tensions	18
	Terms and Conditions of Sale	19
	Declaration of Conformity	20
	Index	23

FIGURES

FIGURE 1.	Cut-away View of Transducer	1
2.	Strain Gage Connections	2
3.	Dimensions	3
4.	Tension Zones	5
5.	Formulas for Net Force from Roll Weight	7
6.	Formulas for Net Force from Tension	8
7.	Example of a Standard Transducer Orientation	9
8.	Bearing Mounting Bolt Length	10
9.	Connection to the Electronics	11
10.	Web Path	12
11.	Model UPB Transducer Connections	17

1.1 GENERAL DESCRIPTION

The Model SUPB Tension Transducer is an electro-mechanical device that converts web tension into a dc voltage which is proportional to tension. The voltage is amplified in external electronic circuitry and displayed on an analog or digital meter which is calibrated to indicate actual web tension, expressed in pounds, ounces, grams, kilograms, newtons or any other desirable units. It can also be supplied to a regulator circuit to control tension automatically.

The information in this Section will help give a clear understanding of the Model SUPB Transducer, how it works and how it is used.

1.2 CONSTRUCTION AND MECHANICAL OPERATION (see Figure 1)

In a typical installation, a transducer is mounted on each end of a standard idler roll. The roll shaft is secured to the transducer using a pillow block bearing or a shaft hanger, depending whether the shaft is rotating (live) or non-rotating (dead).

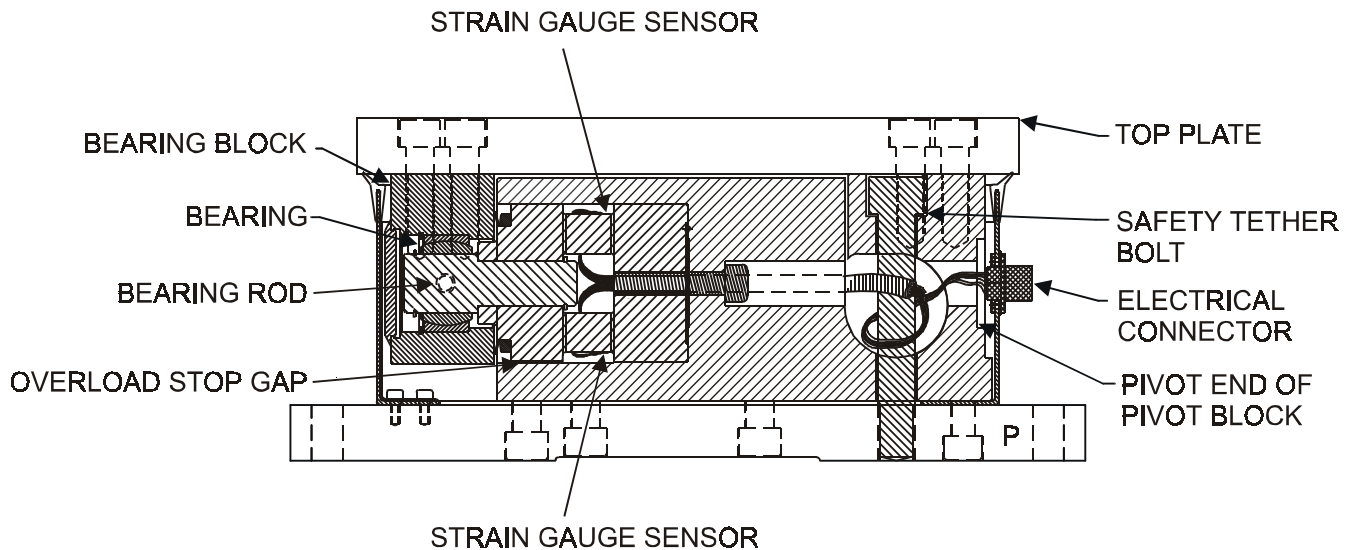

Figure 1 - CUT-AWAY VIEW OF MODEL SUPB TRANSDUCER

The SUPB Transducer can be installed in any position. But, when installed at a 45° angle so the roll weight is directed through the pivot end, the idler roll weight does not affect the output.

Inside the pivot block is a parallel web sensing beam with strain gages mounted on the outside surfaces. Load from the top plate pivots about the pivot end of the pivot block onto the bearing block. The alignment bearing is free to slide on the precision ground and hardened steel bearing rod so that the sensing beam is only sensing perpendicular force. All components of non-perpendicular applied loads pivot about the pivot end and result in additional perpendicular force to the sensing beam.

A very small deflection of the sensing beam causes a consistent repeatable voltage difference across the two gages which are powered in the half Wheatstone Bridge configuration.

The base of the sensing beam is mounted in a high precision bore in the pivot block and has a stop diameter bore at the bearing end which stops deflection and prevents beam damage from accidental overloads.

1.3 ELECTRICAL OPERATION (see Figure 2)

The Model SUPB Transducer is used in pairs, one on each end of an idler roll shaft. Web tension exerts a force on the roll which is transmitted to the beam by the top plate. Two semiconductor strain gages are mounted on the beam, on the outside surfaces. As force is applied and the beam deflects, one gage is stretched and the other gage is compressed. This increases the electrical resistance of the stretched gage and decreases the resistance of the compressed gage. The gages in both transducers are electrically connected together in a Wheatstone bridge configuration. The bridge produces double the output of a single transducer and averages the outputs so web position, width and loose or tight edges do not affect the accuracy of the tension signal.

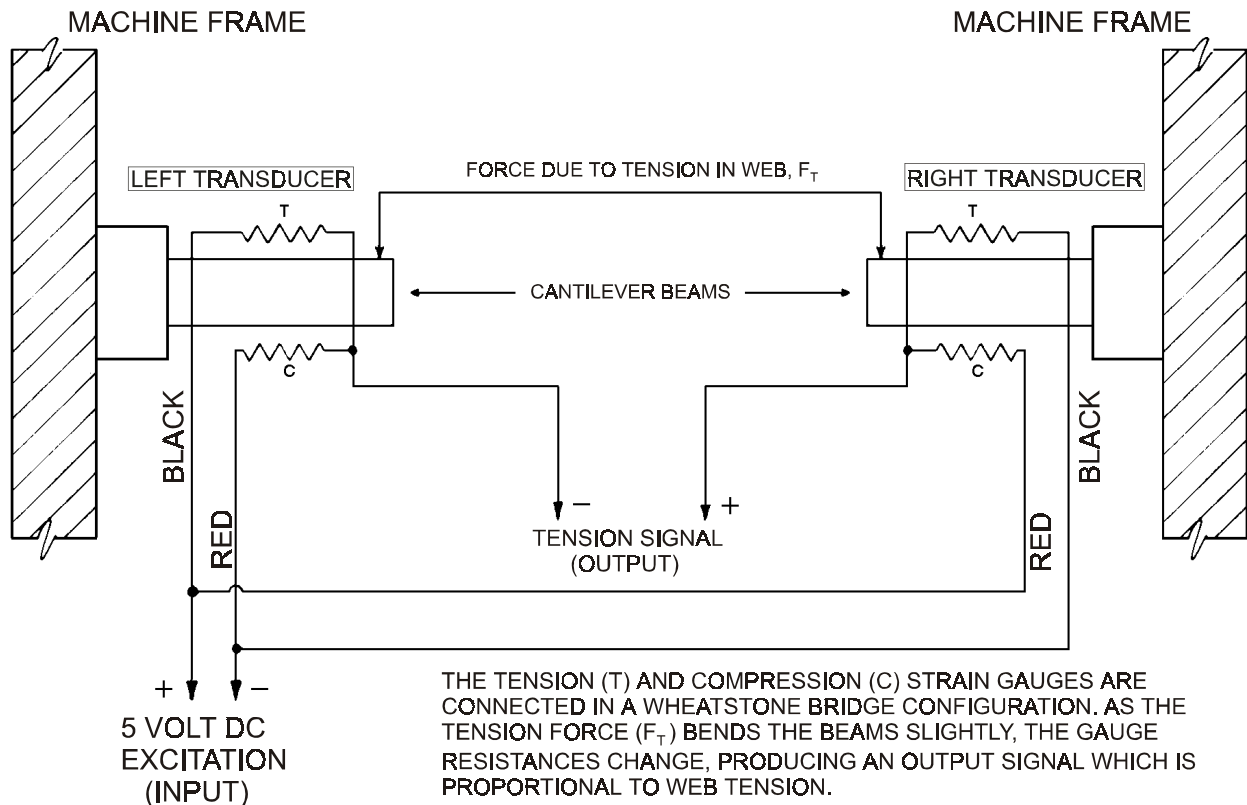

Figure 2 - STRAIN GAGE CONNECTIONS

The physical location of the strain gages, isolated within the mass of the pivot base (end stamped "P"), ensures that each gage experiences the same temperature variations. This, and the Wheatstone bridge configuration, provides automatic temperature compensation and a stable output.

The strain gages are high output semiconductor devices which typically have an output sixteen times greater than the inexpensive foil gages used in some transducers. Therefore, the signal amplifier used with these Model SUPB transducers is a very stable low-gain design. The inherent benefit of the high output gages is immunity to electrical noise.

One transducer can be used alone if its sensing beam is made with four gages wired in a full Wheatstone bridge configuration.

1.4 SPECIFICATIONS

Electrical Specifications:

Excitation Voltage	5 Volts dc (10V with XR option)
Full Scale Output	250 mVdc nominal (500mVdc with XR)
Strain Gage Resistance	100 ohms nominal (200 ohms, XR)
Non-Repeatability	± 1/4% full span (FS)
Non-Linearity & Hysteresis Combined	± 1/2% FS
Temperature Range	-10°F to +200°F (-23°C to +93°C)
Temperature Coefficient	0.02% per deg. F typical, 0.036% per deg. C typical
Electrical Connections	pin A....white wire..output
	pin B....black wire.....5V
	pin C....red wire.....5V
Mating Electrical Connector	Amphenol MS3106A-10SL-3S

Mechanical Specifications:

Materials	303/304 stainless steel and aluminum
Top Plate Displacement	0.010" (0.25mm) Size 2
	0.015" (0.38 mm) Size 3
Load Ratings: Size 2	100, 200, 400, 800, 1200 lbs. (450, 900, 1800, 3600, 5350 N)
	Size 3 1000, 2500, 5000 lbs. (4450, 11125, 22250 N)
Static Overload Capacity: Size 2	3000 lbs. (8900 N)
	Size 3 10,000 lbs. (66,750 N)
Load Direction	± 45° of perpendicular to top plate
Weight: Size 2	9 lbs. (3 kg)
	Size 3 30 lbs. (14 Kg)

1.5 STANDARD FEATURES

- Stainless Steel and Aluminum construction. Excellent corrosion resistance.
- Load Ratings to 5000 lbs.
- Low maintenance design - lifetime lubricated.

1.6 OPTIONS

- **Drilled and Tapped top plate (DT).** Top plate drilled and tapped for bearing.
- **Environmental Connector (EC)** - Seals with mating cable environmental connector to protect against electrical contact oxidation; especially useful in corrosive environments.
- **Extended Range output (XR)** - Produces twice the output signal for a given load rating. Must be used with electronics having extended range option.
- **Full Bridge (FB)** - Four strain gages in each transducer instead of two. Wheatstone bridge configuration. Used only when a single SUPB is used.
- **Permanently Attached Cable (PT).** Permanently attached cable instead of amphenol connector.
- **Permanently Attached Cable with connector (PTC).**
- **Right Angle Connector (RAB).** Allows electrical connector to plug in at 90° angle. Size 2 only.

2.1 DIMENSIONS

SIZE		A	B	C	D	E	F	H	K	L	M	N	O	P	R	S
2	in.	2.62	9.00	2.88	2.62	3.80	0.45	8.00	8.00	---	0.53	1.36	0.95	4.54	1.31	0.56
	mm.	67	229	73	67	96	11	203	203	---	14	34	24	115	33	14
3	in.	4.50	13.50	5.74	4.12	---	0.94	12.25	11.25	2.75	0.53	2.97	1.65	6.82	---	0.94
	mm.	114	343	146	105	---	24	311	286	70	14	75	42	173	---	24

Note: Connector position is on long side for Size 2, and pivot end for Size 3

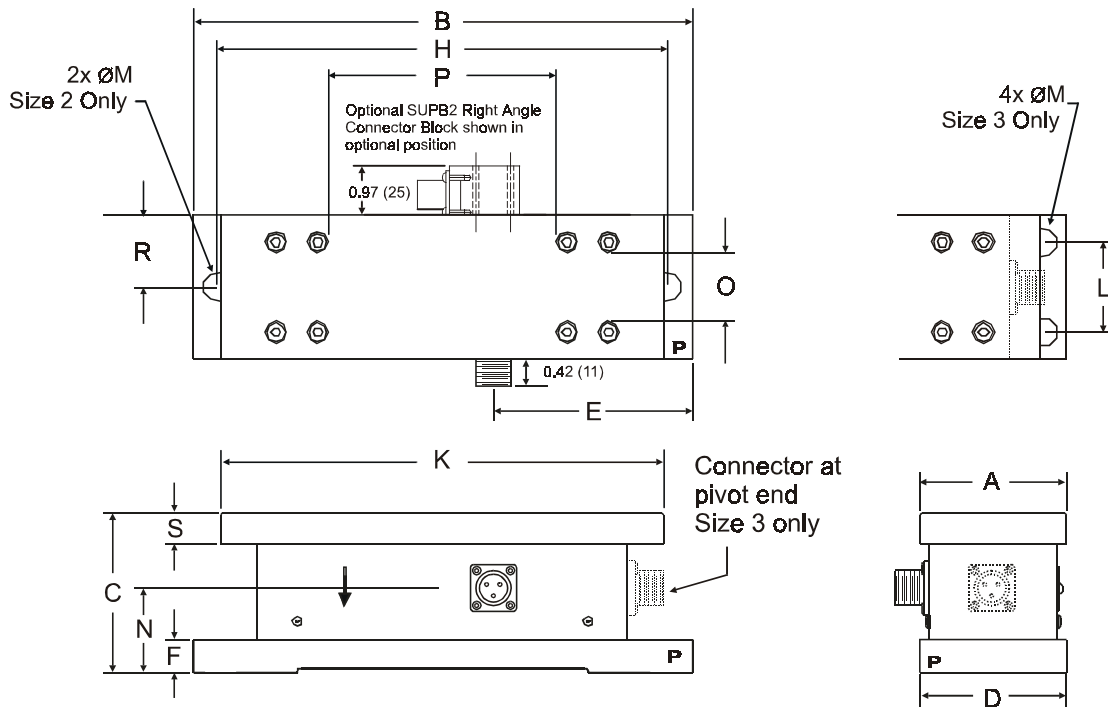
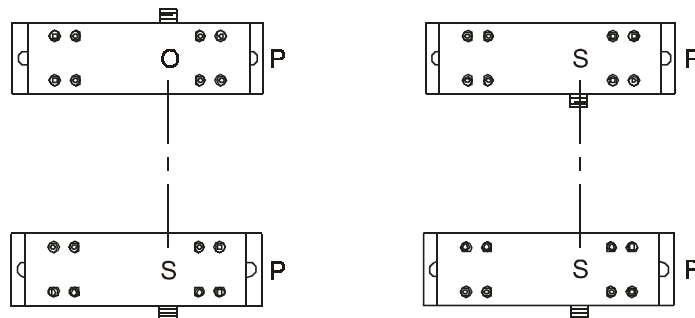

Figure below for Size 2 SUPB's only.



"P" Denotes Pivot End of Transducer
 "S" Denotes Standard Connector Position
 "O" Denotes Optional Connector Position

Figure 3 - DIMENSIONS

2.2 PRE-INSTALLATION REQUIREMENTS

A. TRANSDUCER ROLL

The Model SUPB Transducers are used in pairs. One is mounted on each end of an idler roll shaft. The roll chosen is called the Transducer Roll.

1. **THE TRANSDUCER ROLL MUST BE A TRUE IDLER!** It can **NOT** be a driven roll! There can be **NO** brakes, clutches, belts, chains or gears attached to it or its shaft. It can not be a nip roll or be in contact with a nip roll. It can not be filled with water or have pipes or hoses attached to it. **NOTHING MUST CONTACT THE ROLL OR ITS SHAFT EXCEPT THE WEB!**
2. The Transducer Roll shaft may be non-rotating or rotating. If the shaft is rotating, it must be designed and built for rotating service. Usually this means that it is straight, dynamically balanced and strong enough to resist bending from web tension forces.
3. The roll must be **DYNAMICALLY BALANCED** if web speed is over 300 FPM! Refer to **Section 2.4.3: BALANCE THE ROLL** for specifications. An unbalanced roll will reduce the accuracy of the tension signal.

B. WRAP ANGLE

The web must always contact the transducer roll in exactly the same way. The wrap angle must not change as the unwind or rewind roll diameter changes. Therefore there must be at least one idler roll between the transducer roll and the unwind or rewind shaft. If the machine has more than one webbing path, be sure to choose a roll that is wrapped the same for each. Otherwise it will be necessary to install an additional pair of transducers, or dual calibration circuitry, or both. If the wrap angle is allowed to change, the transducer output will change with angle as well as tension, and accuracy will be reduced.

C. MOUNTING SURFACE.

The structure on which the transducers are mounted **MUST** be very stable and strong. Any movement of the structure may be sensed by the transducers and may cause inaccurate tension readings. The surfaces must also be smooth and flat so the transducers won't be cocked when they are installed.

D. TENSION ZONE.

The roll must be located in the tension zone which is to be monitored or controlled. The beginning or end of any tension zone is always at a nip (driven or braked), unwind shaft, rewind shaft or drag bar. Any element in the web path that can change web tension is at one end of a tension zone.

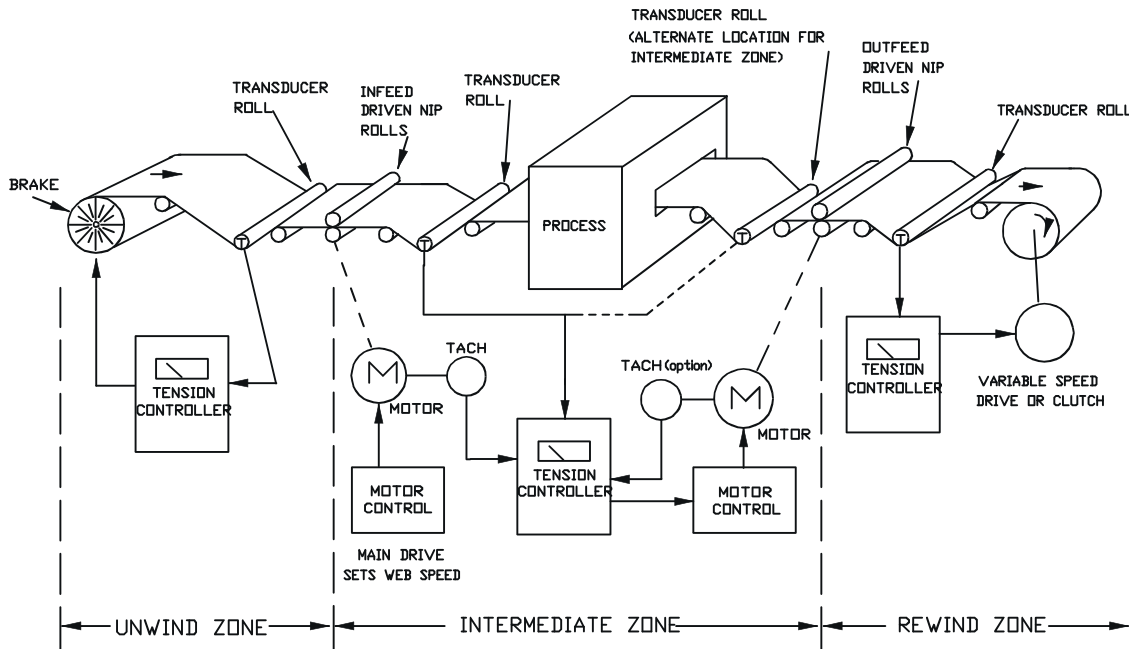

Figure 4 - TENSION ZONES

2.3 SELECTION OF LOAD RATING

A. FACTORS AFFECTING LOAD RATING SELECTION

The SUPB transducer is designed to measure forces which are mostly perpendicular to the top plate. It is available in eight load ratings: 100, 200, 400, 800, and 1200 for Size 2, and 1000, 2500, and 5000 lbs for Size 3. The load rating appropriate for a particular web application depends on the transducer's mounting orientation, roll weight, web tension, wrap angle, and direction of tension force.

The transducer can be mounted in any angular orientation about the roll axis. It is designed for sensing tension force with direction ' F_T ' within $\pm 45^\circ$ of the line 'V' which is perpendicular to the transducer top plate (see Figure 6). It will function accurately outside of this $\pm 45^\circ$ range, but the following load rating equations are not as accurate for prediction outside of this range. Outside of this angular range, DFE's model UPBH transducer should be used. The UPBH transducer is used to measure tension with the applied force directed mostly parallel to the top-plate.

When looking at the SUPB transducer orientation sketches on the next page, note that the side view of each transducer shows one end as the pivot end (stamped 'P'). This designation distinguishes this end of the transducer's internal pivot end from the other end, which is the sensing-beam end. The pair of transducers are supporting a shaft and must have the pivot end to the same side of the shaft. Because of its asymmetric internal design, the transducer is significantly more sensitive to non-perpendicular applied force directed through the sensing-beam end than through the pivot end.

As a result, calculating net force and selecting a load rating are not as straightforward as with other transducers. We strongly recommend that you ask your sales representative or one of DFE's applications engineers to select a load-rating for your application.

If you wish to calculate the correct total net force for an application yourself, follow the Load Rating Selection instructions on the next page. Note that total net force is the sum of two components: net force from roll weight and net force from web tension.

The correct load rating for a SUPB transducer pair can then be selected by matching your calculated total net force to the range of values from the corresponding Max. Net Force list.

B. SELECTING THE LOAD RATING

To select the correct load rating for an SUPB transducer (to be used in a pair), look at Figures 5 & 6. You will need to calculate Net Force from Roll Weight and Net Force from Tension being sure to maintain their current algebraic sign (+,-). The sum of these net force components equals the Total Net Force used to select the correct load rating.

F_T = direction of force midway between two tensions

V = line 'V', perpendicular to mount surface and top plate

1. Enter values from your application for the equation variables below.

T = max. tension in web _____

W = weight of roll and support bearings _____

A = angle between weight 'W' direction and line V _____

B = web wrap angle ($=180^\circ - C$ in diagram 2) _____

D = angle between tension force direction F_T and line V _____.

Dimensional Constants inches (mm)

Size 2

L = 2.4 (61)

H = 1.5 (38) + a*

*a = 1.0 (25.4) to 2.5 (63.5)

Size 3

4.5 (114)

3.0 (76) + a*

1.5 (38.1) to 3.0 (76.2)

*Where "a" is the idler roll shaft center height from the top plate surface. If the tension force F_T is directed through the pivot end of the transducer at $D = 45^\circ$, then when the pillow block height is more than the minimum height specified above, the output signal polarity will be reversed.

- Refer to the Diagram 1 (Fig. 5) formulas for Net Force from Roll Weight. Determine whether the roll weight will be pushing toward or pulling away from the top plate, and whether the direction of the weight from the center of the roll is pointed in the 90° quadrant on the left or the right of line V (observe the pivot end marked “P”).

Plug the values for your variables (and the dimensional constants) into the associated equation that most closely matches your application. Calculate the Net Force from Roll Weight. Note: It is critical to maintain the algebraic sign (“+” or “-”) in the result.

For two transducers if two (2x) the Net Force from Roll Weight calculated below is more than 95% of the load rating chosen, the tension meter will probably not be adjustable to zero. If this is the case, one or more of the following changes must be made:

- Reduce the transducer weight.
- Decrease Angle A.
- Use the next higher load rating. Please consult DFE for advice.

- Refer to the Diagram 2 (Fig. 6) formulas for Net Force from Tension. Select the drawing that most closely matches your application in terms of F_T direction relative to line V (observe the pivot end marked “P”). Calculate the Net Force from tension. Maintain algebraic sign (+,-).

Note: When the calculated Net Force from Tension is negative (i.e. pulling away from the transducer) it is necessary to reverse the signal polarity in associated electronics (indicators or controllers). This optional reverse polarity can be specified when purchasing DFE electronics.

- Add the Net Force from Weight and the Net Force from Tension paying close attention to the algebraic sign of each component. Use the total to select the appropriate load rating (lbs) from the list below.

Size	Max. Net Force lbs. (Newtons)	Load Rating lbs. (Newtons)
2	up to 120 (550 N)	100 lbs. (450 N)
	240 (1075 N)	200 lbs. (900 N)
	480 (2150 N)	400 lbs. (1800 N)
	960 (4275 N)	800 lbs. (3600 N)
	1440 (6425 N)	1200 lbs. (5350 N)
3	up to 1200 (5350 N)	1000 lbs (4450 N)
	3000 (13350 N)	2500 lbs (11125 N)
	6000 (26700 N)	5000 lbs (22250 N)

- To get expected results, be sure the installers are given the details of mounting orientation, pivot end (stamped “P”), and tension direction. If the Net Force has a negative (-) value, the output signal from associated electronics will need to be reversed. Application sketches are helpful.

DIAGRAM 1:

CASE A: Weight pushing toward top plate

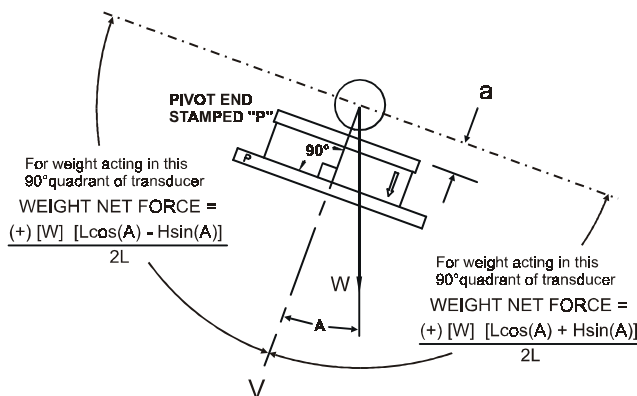

CASE B: Weight pulling away from top plate

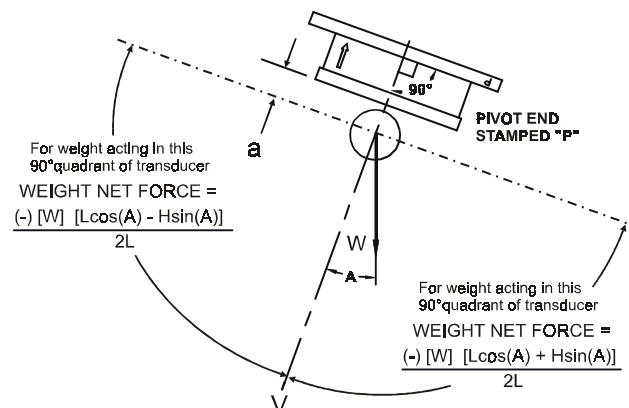

Figure 5 - FORMULAS FOR NET FORCE FROM ROLL WEIGHT

DIAGRAM 2:

NOTES:

- If F_T is perpendicular (Angle $D = 0^\circ$) and toward the top plate, either of the two drawing/formulas on the left can be simplified to $+2T \sin(B/2)$.
If F_T is perpendicular (Angle $D = 0^\circ$) and pulling away from the top plate, either of the two drawing/formulas on the right can be simplified to $-2T \sin(B/2)$.
- These tension force equations have an oversizing factor of two (2) for tension surges.

Angle (Degrees)	SINE	COSINE
0	.000	1.000
5	.087	.996
10	.174	.985
15	.259	.966
20	.342	.940
25	.423	.906
30	.500	.866
35	.574	.819
40	.643	.766
45	.707	.707
50	.766	.643
55	.819	.574
60	.866	.500
65	.906	.423
70	.940	.342
75	.966	.259
80	.985	.174
85	.996	.087
90	1.000	.000

WRAP 1

F_T pushes toward top plate and away from pivot end

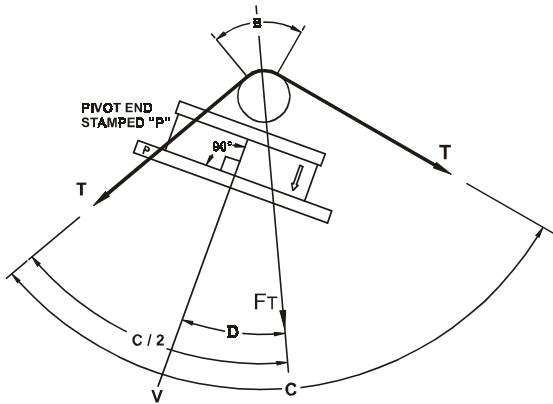

TENSION NET FORCE =

$$\frac{(+)[4T \sin(B/2)][L \cos(D) + H \sin(D)]}{2L}$$

WRAP 3

F_T pulls from the top plate and away from pivot end

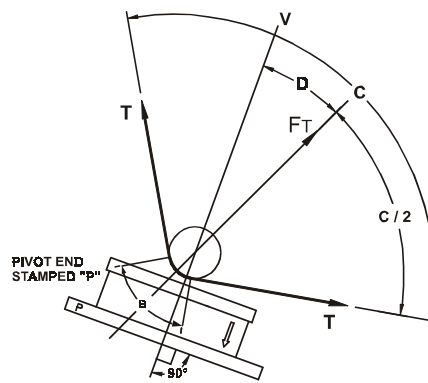

TENSION NET FORCE =

$$\frac{(-)[4T \sin(B/2)][L \cos(D) - H \sin(D)]}{2L}$$

D must not exceed 45° for Wraps 1, 3, & 4

WRAP 2

F_T pushes toward top plate and toward pivot end

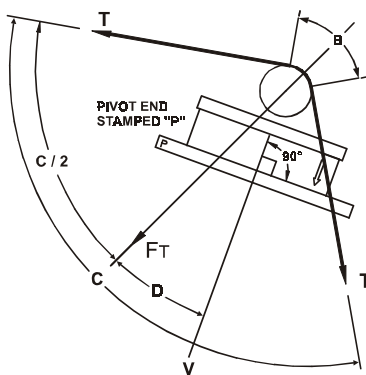

TENSION NET FORCE =

$$\frac{(+)[4T \sin(B/2)][L \cos(D) - H \sin(D)]}{2L}$$

WRAP 4

F_T pulls from the top plate and toward pivot end

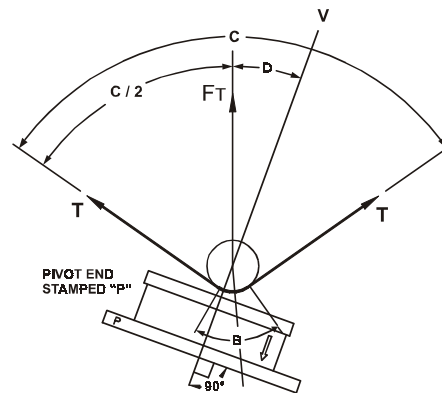

TENSION NET FORCE =

$$\frac{(-)[4T \sin(B/2)][L \cos(D) + H \sin(D)]}{2L}$$

D must not exceed 30° for Wrap 2

Figure 6 - FORMULAS FOR NET FORCE FROM TENSION

2.4 INSTALLING THE TRANSDUCERS

Model SUPB Transducers are very easy to install. Normally, both transducers are mounted on the machine and the roll is then installed on them. Follow the simple steps below.

1. MOUNT THE TRANSDUCERS ON THE MACHINE

Mount the transducers on the machine making sure that the transducer force direction and mount surface is the same as that used when the transducer load rating was sized for this application, and that the stamped pivot ends of both transducers are on the same side of the roll. Differences may result in significant unsatisfactory performance.

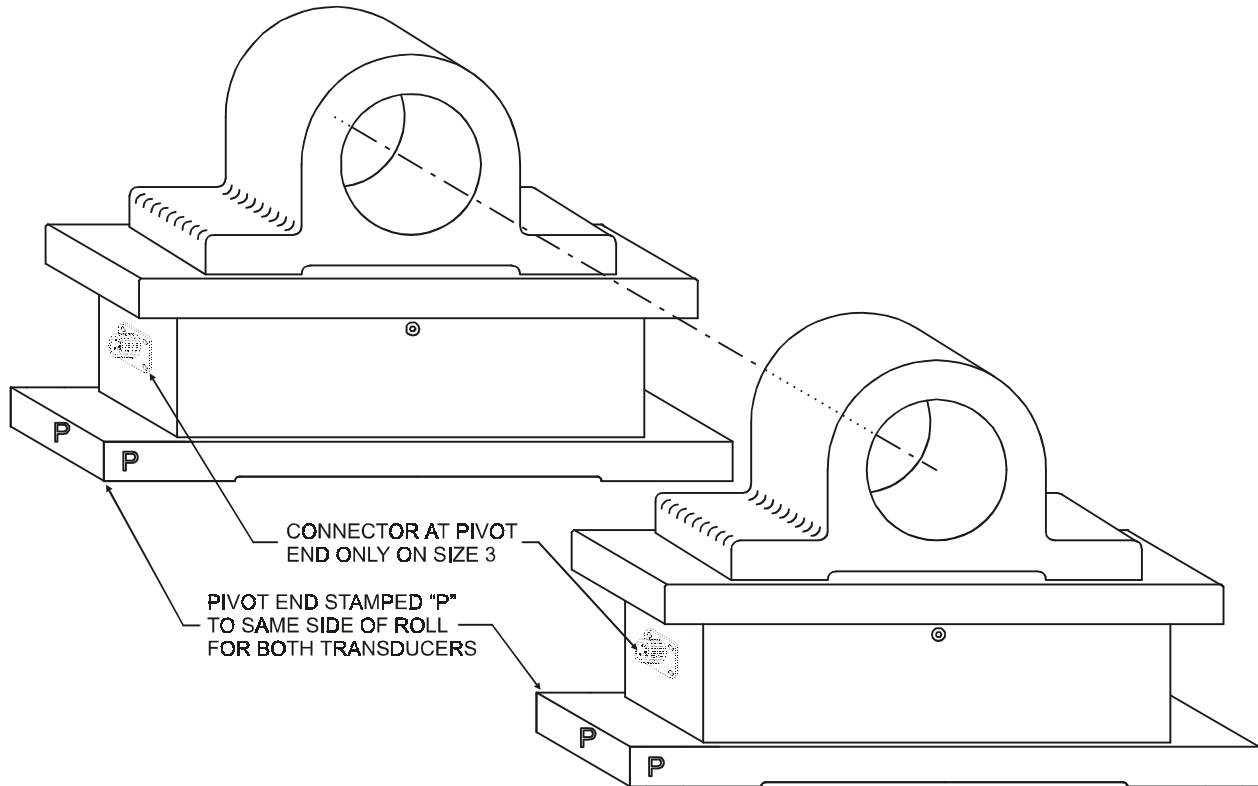

Figure 7 - EXAMPLE OF A STANDARD TRANSDUCER ORIENTATION

2. DETERMINE SHAFT LENGTH

Measure the center to center distance between the transducer bases, (call this D_T). Use the following formula to determine the minimum shaft length.

$$\text{SHAFT LENGTH} = D_T + \text{width of one pillow block bearing}$$

3. BALANCE THE ROLL

The roll must be dynamically balanced if web speed is 300 FPM or more. Balance the roll to Quality Grade G-2.5 as described in ISO 1940 and ANSI S2.19-75 standards. If these standards are not available, please contact **DOVER FLEXO ELECTRONICS** and we will provide the appropriate data.

4. SELECTION OF PILLOW BLOCK BEARING

The bearing should have self-aligning and floating capabilities. The self-aligning feature will avoid unnecessary stress on the transducers caused by misalignment during installation and by roll deflection during operation. The floating feature will avoid forces caused by temperature variations of the shaft. These factors could cause inaccurate output from the transducers. Normally, only one bearing needs to float (move axially a small amount). The other can be fixed. A 100° F temperature change causes approximately 1/8" change in length of a 10 ft. long piece of steel.

5. REMOVE THE TOP PLATE TO DRILL FOR THE PILLOW BLOCK BEARING

1. Remove the eight screws holding the top plate to the transducer.
2. Remove the top plate and drill and tap the holes for the pillow block bearing being used.
3. Replace the top plate and secure with the eight screws. Tighten the screws to 6 ft.-lbs. of torque for Size 2, and 30 ft.-lbs of torque for Size 3.

6. INSTALL THE ROLL AND BEARINGS ON THE TRANSDUCERS

1. Place the bearings loosely on the roll shaft.
2. Place the bearings and roll on the transducers and mount the bearings to the transducers with the appropriate cap screws. The length of the cap screws should be sufficient to anchor the bearings, but not so long as to exceed the maximum thread engagement with the top plate (0.560" for Size 2, and 0.937 for Size 3). If the cap screw is too long, the bearing will not clamp tightly to the top plate and the screw will interfere with load transfer to the sensing beam.

CAUTION! Do not use a bolt which is too long!

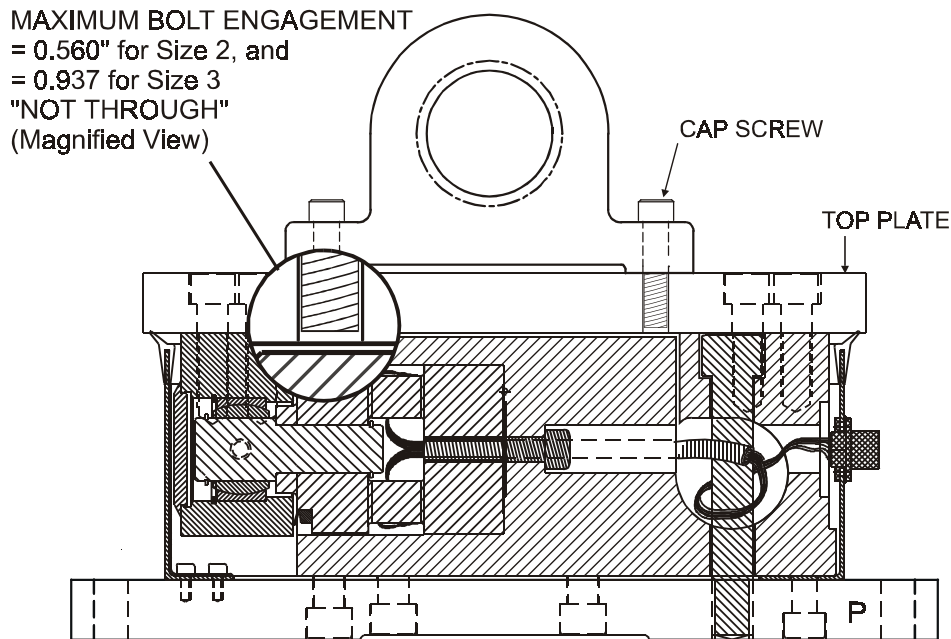

Figure 8 - BEARING MOUNTING BOLT LENGTH

3. Fasten the shaft in the bearings at this time. Be sure the floating bearing is installed with the axial gap on the side of the bearing facing the shaft end so the shaft can grow in length as it gets hot, without causing stress on the bearing and transducer.

2.5 REMOVAL OF ROLL AND/OR TRANSDUCERS

To remove the transducers, first support the idler roll so it won't fall. Then, follow the procedure below to remove the roll and bearings from the transducers.

PROCEDURE FOR REMOVING ROLL AND PILLOW BLOCKS

1. Support the idler roll so it won't fall.
2. Remove the screws that secure the bearings to each transducer top plate.
3. Take the roll and bearings off of the transducers.

PROCEDURE FOR REMOVING TRANSDUCERS

1. Disconnect the electrical cable on each transducer.
2. Remove the screws mounting the transducer and repeat for the opposite side.

3.1 INTRODUCTION

There are no calibration adjustments on the Model SUPB Transducer itself. The instructions below are for the electronics which the transducers are connected to. All of the following terminology and procedures, assume that the transducers are connected to a **DOVER FLEXO ELECTRONICS** tension controller or tension indicator. If some other electronics are being used, you should follow the instructions furnished with them.

These are general instructions which are correct for most **DFE** controllers and indicators, and are placed here for your convenience. If you have any difficulty calibrating or if there is any discrepancy between these instructions and those in the Instruction Manual for the indicator or controller, you should disregard these instructions and follow the instructions in the Manual for the indicator or controller.

The transducers must be properly installed and orientated as directed in **SECTION 2.4**.

3.2 CONNECTION TO THE ELECTRONICS

The SUPB transducer is most sensitive to loads applied in a direction perpendicular to the top plate. If the tension force pushes on the top plate, the output will be positive, however, pulling on the top plate will result in negative output. Positive output is compatible with all electronics, but negative output will not be.

It is therefore recommended that if the tension force pushes toward the top plate, the transducers be connected exactly as stated in the electronics manual, and that if the tension force pulls away from the top plate, the excitation voltage polarity must be swapped at the electronics as shown in **Figure 8** to establish positive control and indication of tension. This can be done internally to DFE electronics and still use standard cable connections.

TENSION RESULTANT FORCE (F) PUSHES TOWARD TOP PLATE OF SUPB

TENSION RESULTANT FORCE (F) PULLS AWAY FROM TOP PLATE OF SUPB

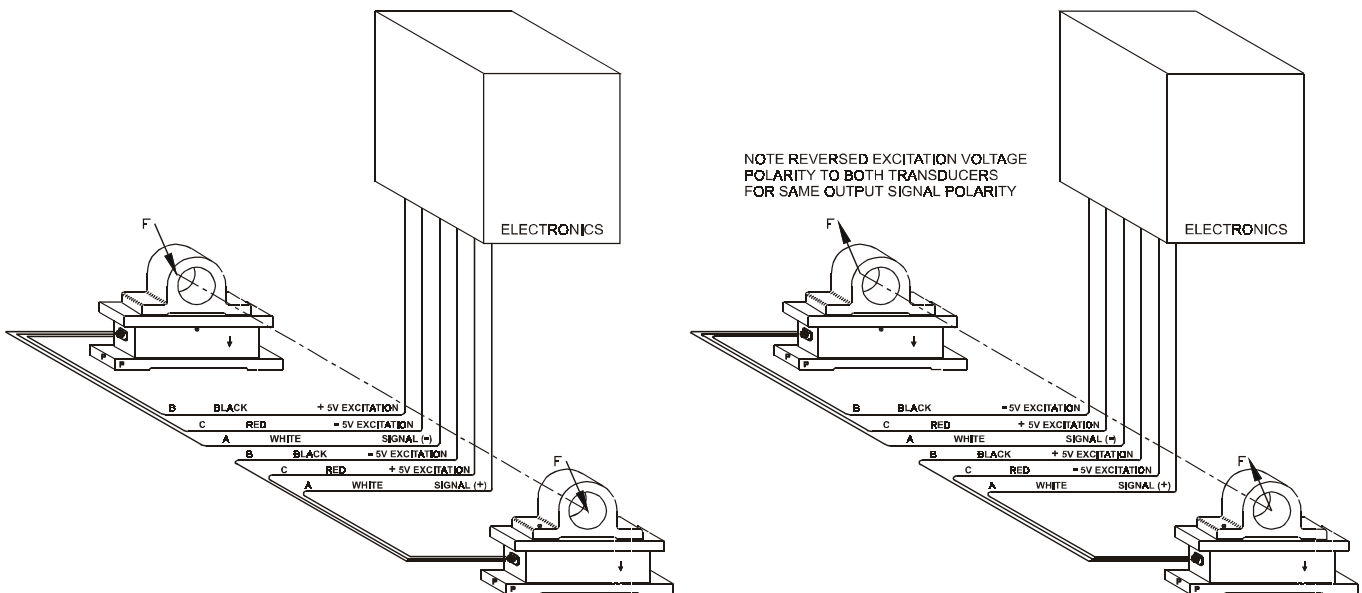

Figure 9 - CONNECTION TO THE ELECTRONICS

3.3 ZERO THE TENSION METER

1. Turn the "POWER" switch off. If the meter does not read zero, turn the mechanical adjustment screw on the meter face so the needle indicates zero tension.
2. Find an object that weighs at least 25% of the maximum value on the tension meter scale. (Be sure you know the exact weight).
3. Find a rope, tape, or wire that will support the weight in 2. above.
4. Verify that there is no web contacting the Transducer Roll. Turn the "POWER" switch on. Wait a few seconds for the tension meter to settle. Turn the "CALIBRATE" pot. to approximately 75%. Then, turn the "ZERO" pot. so the tension meter reads zero tension.

3.4 CALIBRATE THE TENSION METER

See Figure 9. Pass the rope over the Transducer Roll in exactly the same path as the web follows. Tie the end in the machine at least one idler roll beyond the Transducer Roll. Pass the other end by at least one idler roll before the Transducer Roll. Be sure the rope does not pass over any driven rolls, braked rolls or dead bars. (This will cause inaccurate calibration). Attach the weight to the free end of the rope and let it hang without touching anything. Turn the "CALIBRATE" pot. so the tension meter reads the same as the weight. Remove the weight and rope. This concludes the calibration procedure.

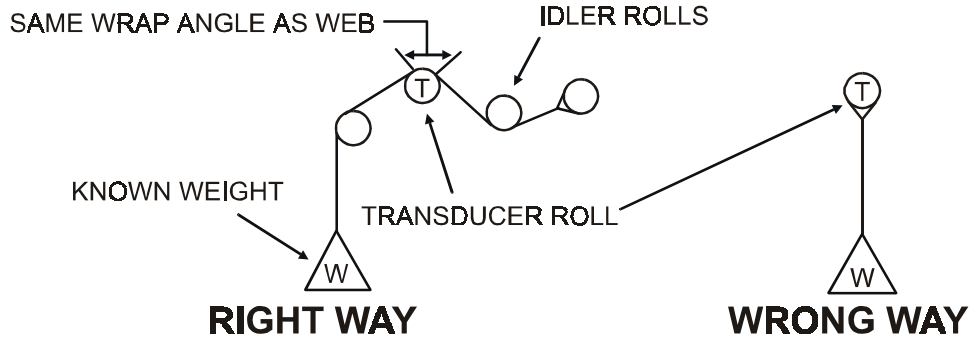

Rope follows web path exactly. All rolls must be free turning idlers.

Figure 10 - WEB PATH

Your Dover Flexo Model SUPB Tension Transducers have been manufactured of quality materials. The model SUPB bearing rod is hardened to Rockwell 60C, then ground to size with close tolerances. For the highest beam rating, the spherical alignment bearing is oversized by more than a factor of 6 for static load. For worst case dynamic load with an unbalanced machine roll, there is an oversizing factor of more than 2. The bearing is coated with a Molybdenum Disulfide lube and contained in a sealed bearing block which is packed with grease.

With proper application and installation your transducers will be relatively maintenance free and long lasting. Any changes in your application which affect the dynamics of your equipment such as web speed, net force, material, etc. could possibly require upgrading of load rating or roll change. Contact Dover for specific information and engineering approval.

This is a list of problems which could occur during initial start-up or afterwards. The probable causes are listed with the most likely one first and the least likely one last.

1. TRANSDUCER ROLL SHAKES, VIBRATES or BOUNCES

- a. Roll is not balanced. See Section 2.4.3 and Section 2.2.A.3.
- b. Shaft is not clamped tightly in bearings. Mounting screws are loose or shaft diameter is undersize.
- c. Transducer mounting bolts are not tight.
- d. Shaft is too weak or there is too much shaft extension between the ends roll and the transducers.
- e. Shaft is bent or too weak. (This refers to live shaft idler rolls, only)
- f. Roll is turning at its natural frequency. Call **DFE** for analysis of conditions and solution to problem.

2. CAN NOT ADJUST TENSION METER TO READ ZERO WHEN WEB IS SLACK

- a. Transducer roll is too heavy. See Section 2.3.B.2.
- b. Transducers are pre-loaded. See Sections 2.4.2 and 2.4.4.

3. TENSION METER READS BACKWARDS

- a. Transducers are installed backwards with force arrow pointing in opposite direction. See Section 2.4.1.
- b. Transducer cables are connected wrong at controller/indicator terminal strip. Signal wires are reversed.

4. TENSION METER NEEDLE PEGS HIGH OR LOW

- a. Meter is not electrically adjusted to zero. See Section 3.3.
- b. Transducers are pre-loaded. See Sections 2.4.2 and 2.4.4.
- c. Transducer cable has broken wire, poor connection or short circuit.
- d. A strain gage has failed. To verify: Unplug the transducer cable and use an ohm-meter to measure the resistance of the gages at the connector on the transducer. Measure between pins A,B, and A,C. In each case, the resistance should be about 100 ohms. Measure the resistance between any pin and the outside of the transducer. The meter should read infinite resistance. Apply a force to the roll by hand or by using a rope and a weight, in the direction of the tension force and maintain it while again measuring between pins A,B and A,C. The resistance should be only a few ohms different from before.
- e. Failure in the tension amplifier circuit of the controller/indicator.

5. TENSION METER DOES NOT READ ZERO WHEN WEB IS SLACK AND READING DRIFTS WITH TIME.

- a. Meter is not calibrated. See Section 3.4.
- b. Transducers are pre-loaded. See Sections 2.4.2 and 2.4.4.
- c. The structure the transducers are mounted on is weak. See Section 2.2.C.
- d. Transducer cable has a broken wire, poor connection or short circuit.
- e. A strain gage is cracked. Perform the test in 4d above.

- 6. TENSION METER DOES NOT READ THE SAME EACH TIME THE SAME FORCE IS APPLIED** (poor repeatability)
 - a. Transducers are pre-loaded. See Sections 2.4.2 and 2.4.4.
 - b. The structure the transducers are mounted on is weak. See Section 2.2.C.
 - c. The bearing or transducer mounting screws are loose.
- 7. TENSION METER READING DOES NOT CHANGE WHEN FORCE IS APPLIED TO ROLL. METER READS ZERO.**
 - a. Meter is not calibrated. See Section 3.4.
 - b. Force direction arrow on one transducer is backwards. See Section 2.4.1.
 - c. Transducer roll is too heavy. See Section 2.3.B.2.
 - d. Transducer cable has broken wire, poor connection or short circuit.
 - e. Transducer cables connected incorrectly, or to wrong transducers.
 - f. Failure of tension amplifier circuit in controller/indicator. Unit not turned on.
- 8. TENSION METER NEEDLE BOUNCES**
 - a. Web tension is fluctuating because of machine speed fluctuations, bent roll shafts, worn idler roll bearings, chattering unwind brake, flat spot in unwind or rewind roll, etc.
 - b. Shaft is loose in the bearings. Bearing mounting screws are loose or shaft diameter is under-size.
 - c. Transducer mounting bolts are loose.
 - d. Tension controller is not adjusted properly. See controller Instruction Manual for procedure.

6.1 REPLACEMENT PARTS FOR THE SUPB TRANSDUCERS

TOP PLATE:

Size 2: 203-1843

Size 3: 203-1584

CONNECTORS:

Sizes 2 & 3: MS3102A-10SL

<u>CABLES:</u>	<u>15 FT.</u>	<u>20 FT.</u>	<u>25 FT.</u>	<u>30 FT.</u>
C - C:	721-1554	721-1539	721-1540	721-1541
w/ Rt. Angle Conn	721-0083			
C - N:	721-1555	721-1542	721-1542	721-1544
w/Rt. Angle Conn	721-1555			

INSTRUCTION MANUAL: DOC 801-0906

MODELS C, RS, AND UPB TRANSDUCERS

THE TENSION (T) AND COMPRESSION (C) STRAIN GAGES ARE CONNECTED IN A BRIDGE CONFIGURATION. AS THE BEAMS BEND SLIGHTLY UNDER WEB TENSION, THE GAGE RESISTANCES CHANGE PRODUCING AN OUTPUT SIGNAL WHICH IS DIRECTLY PROPORTIONAL TO THE WEB TENSION.

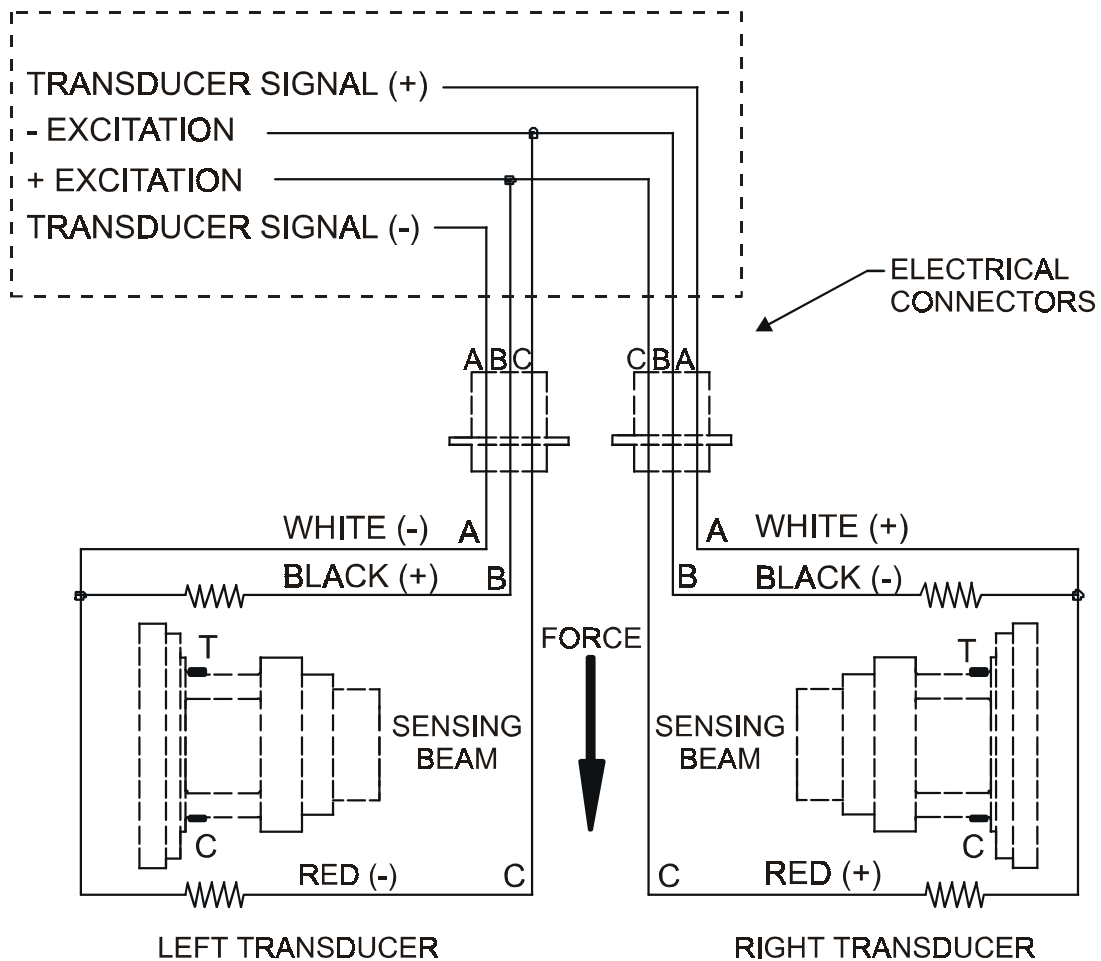

Figure 11 - MODEL UPB TRANSDUCER WIRING

Appendix B: Typical Tensions for Various Materials

TYPICAL TENSIONS FOR WEB MATERIALS

ACETATE		0.5 lb. per mil per inch of width	
FOIL	Aluminum	0.5 lb. per mil per inch of width	
	Copper	0.5 lb. "	
CELLOPHANE		0.75 lb. per mil per inch of width	
NYLON		0.25 lb. per mil per inch of width	
PAPER	15 lb *	0.4 lb. per inch of width	
	20 lb	0.5 lb. "	
	30 lb	0.75 lb. "	
	40 lb	1.25 lb. "	
	60 lb	2.0 lb. "	
	80 lb	3.0 lb. "	
	100 lb	4.0 lb. "	
* based on 3000 sq. ft. ream			
PAPERBOARD	8pt	3.0 lb. per inch of width	
	12pt	4.0 lb. "	
	15pt	4.5 lb. "	
	20pt	5.5 lb. "	
	25pt	6.5 lb. "	
	30pt	8.0 lb. "	
POLYETHYLENE		0.12 lb. per mil per inch of width	
POLYESTER (Mylar)		0.75 lb. per mil per inch of width	
POLYPROPYLENE		0.25 lb. per mil per inch of width	
POLYSTYRENE		1.0 lb. per mil per inch of width	
RUBBER	<u>GAUGE</u>	<u>AT 25% STRETCH</u>	<u>AT 50% STRETCH</u>
	10 mil	1.75	3.68
	12 mil	1.10	2.03
	16.5 mil	4.09	8.17
	26 mil	2.47	4.97
SARAN		0.15 lb per mil per inch of width	
STEEL	<u>GAUGE - INS</u>	<u>UNWIND-PSI</u>	<u>REWIND-PSI</u>
	.001 -.005	1000	4000
	.006 -.025	850	3500
	.026 -.040	750	3000
	.041 -.055	650	2600
	.058 -.070	550	2200
	.071 -.090	450	1800
	.091 -.120	450	1400
	.121 -.140	400	1200
	.141 -.165	400	1000
	.166 -.200	400	900
	.201 -.275	400	800
	.276 -.380	300	700
VINYL		0.05 lb. per mil per inch of width	

*** For laminated webs, sum the tension for the individual webs and add 0.1 lb per inch of width.

TERMS AND CONDITIONS OF SALE AND SHIPMENT

1. THE COMPANY

5/1/00

Dover Flexo Electronics, Inc. is hereinafter referred to as the Company.

2. CONFLICTING OR MODIFYING TERMS

No modification of, additions to or conflicting provisions to these terms and conditions of sale and shipment, whether oral or written, incorporated into Buyer's order or other communications are binding upon the Company unless specifically agreed to by the Company in writing and signed by an officer of the Company. Failure of the Company to object to such additions, conflicts or modifications shall not be construed as a waiver of these terms and conditions nor an acceptance of any such provisions.

3. GOVERNING LAW

This contract shall be governed by and construed according to the laws of the state of New Hampshire, U.S.A. The parties agree that any and all legal proceedings pursuant to this contract shall take place under the jurisdiction of the courts of the State of New Hampshire in the judicial district of Strafford County.

4. PENALTY CLAUSES

Penalty clauses of any kind contained in orders, agreements or any other type of communication are not binding on the Company unless agreed to by an officer of the Company in writing.

5. WARRANTY

Dover Flexo Electronics, Inc. warrants its' products to be free of defects in material and workmanship for five years from date of original shipment. Warranty is valid on products purchased on or after April 2, 1999. During the warranty period the Company will repair or replace defective products free of charge if such products are returned with all shipping charges prepaid and if, upon examination, the product is shown to be defective. This warranty shall not apply to products damaged by abuse, neglect, accident, modification, alteration or mis-use. Normal wear is not warranted. All repairs and replacements under the provisions of this warranty shall be made at Dover Flexo Electronics or at an authorized repair facility. The Company shall not be liable for expenses incurred to repair or replace defective products at any other location or by unauthorized persons or agents. This warranty contains all of the obligations and warranties of the Company. There are no other warranties, either expressed or implied. No warranty is given regarding merchantability or suitability for any particular purpose. The Company shall not be liable in either equity or law for consequential damages, losses or expenses incurred by use of or inability to use its' products or for claims arising from same. No warranty is given for products of other manufacturers even though the Company may provide these products with its' own or by themselves. The provisions of this warranty can not be changed in any way by any agent or employee of the Company. Notice of defects must be received within the warranty period or the warranty is void.

6. PAYMENTS

Standard terms of credit are net 30 days from date of shipment, providing satisfactory credit is established with the Company. Amounts past due are subject to a service charge of 1.5% per month or portion thereof or 18% per annum. The Company reserves the right to submit any unpaid late invoices to a third party for collection and Buyer shall pay all reasonable costs of such collection in addition to the invoice amount. All quoted prices and payments shall be in U.S. Dollars.

If the Company judges that the financial condition or payment practices of the Buyer does not justify shipment under the standard terms or the terms originally specified, the Company may require full or partial payment in advance or upon delivery. The Company reserves the right to make collection on any terms approved in writing by the Company's Finance Department. Each shipment shall be considered a separate and independent transaction and payment therefore shall be made accordingly. If

the work covered by the purchase order is delayed by the Buyer, upon demand by Company payments shall be made on the purchase price based upon percentage of completion.

7. TAXES

Any tax, duty, custom, fee or any other charge of any nature whatsoever imposed by any governmental authority on or measured by any transaction between the Company and the Buyer shall be paid by the Buyer in addition to the prices quoted or invoiced.

8. RETURNS

Written authorization must be obtained from the Company's factory before returning any material for which the Buyer expects credit, exchange, or repairs under the Warranty. Returned material (except exchanges or repairs under the Warranty) shall be subject to a minimum re-stocking charge of 15%. Non-standard material or other material provided specially to the Buyer's specification shall not be returnable for any reason. All material returned, for whatever reason, shall be sent with all freight charges prepaid by the Buyer.

9. SHIPPING METHOD AND CHARGES

All prices quoted are F.O.B. the Company's factory. The Company shall select the freight carrier, method and routing. Shipping charges are prepaid and added to the invoice of Buyers with approved credit, however the Company reserves the right to ship freight-collect if it prefers. Shipping charges will include a charge for packaging. Company will pay standard ground freight charges for items being returned to Buyer which are repaired or replaced under the Warranty.

10. CANCELLATION, CHANGES, RESCHEDULING

Buyer shall reimburse Company for costs incurred for any item on order with the Company which is canceled by the Buyer. Costs shall be determined by common and accepted accounting practices.

A one-time hold on any item ordered from the Company shall be allowed for a maximum of 30 days. After 30 days, or upon notice of a second hold, Company shall have the right to cancel the order and issue the appropriate cancellation charges which shall be paid by Buyer. Items held for the Buyer shall be at the risk and expense of the Buyer unless otherwise agreed upon in writing. Company reserves the right to dispose of canceled material as it sees fit without any obligation to Buyer.

If Buyer makes, or causes to make, any change to an order the Company reserves the right to change the price accordingly.

11. PRICES

Prices published in price lists, catalogs or elsewhere are subject to change without notice and without obligation. Written quoted prices are valid for thirty days only.

12. EXPORT SHIPMENTS

Payment for shipments to countries other than the U.S.A. and Canada or to authorized distributors shall be secured by cash in advance or an irrevocable credit instrument approved by an officer of the Company. An additional charge of 10% will apply to any letter of credit. There will be an extra charge for packaging and documentation.

13. CONDITION OF EQUIPMENT

Buyer shall keep products in good repair and shall be responsible for same until the full purchase price has been paid.

14. OWNERSHIP

Products sold are to remain the property of the Company until full payment of the purchase price is made.

DECLARATION OF CONFORMITY

We,

Dover Flexo Electronics
217 Pickering Road
Rochester, NH 03867 USA
Tel: (603) 332-6150
Fax: (603) 332-3758

declare under our sole responsibility that the product:

Model SUPB Web Tension Transducer,

manufactured after the date 1 May 1997, and to which this declaration relates, is in conformity with the following standards or other normative documents:

EN 55011: Radiated and Conducted Emissions
EN 50082-2: Electromagnetic compatibility - Generic immunity standard,
Part 2. Industrial Environment, to include:
ENV 50140: Radio Frequency Immunity - AM
ENV 50141: Conducted Radio Frequency Interference
ENV 50204: Radio Frequency Immunity - Pulse Modulated
ENV 61000-4-2: Electrostatic Discharge
EN 61000-4-4: Electrical Fast Transient Bursts

following the provisions of Council Directive 89/336/EEC of 3 May 1989 on the approximation of the laws of the member states relating to electromagnetic compatibility (the "EMC Directive").

The Technical Construction File is maintained at:

Dover Flexo Electronics
217 Pickering Road
Rochester, NH 03867 USA

Per Annex II R of the Machinery Directive (89/392/EEC):

The machinery, product, assembly, or sub-assembly covered by this Declaration of Conformity must not be put into service until the machinery into which it is to be incorporated has been declared in conformity with the provisions of the applicable Directive(s).

Date of issue: 5 May, 1997

Place of issue: Rochester, NH USA

Signed: Alan H. Wypocki

Alan H. Wypocki, Engineering Manager

NOTES

NOTES

INDEX

Bearing, selection of	9	Options	3
Cables	3, 16	Output	3
Calibration	11	Overload	3
of tension meter	12	Pillow Block Bearing	9
Care and Maintenance	13	Pivot End	1, 4
Declaration of Conformity	20	Repeatability	3
Deflection	3	Replacement Parts	16
Description	1	Specifications	3
Dimensions	4	Strain gages	1, 3, 14
Drill and Tap	3	configuration	2
Dynamically balanced	9	Temperature	
Electrical connections	3, 11	coefficient	3
transducer	17	range	3
Electrical connector		Tension Force	6
environmental	3	Tension Zone	5
position	4, 9	Terms and Conditions	19
right angle	3	Top Plate.....	1, 3, 4, 10, 16
Electrical Operation	2	Transducer roll	5
Excitation Voltage	3	balance	9
Extended Range	3	electrical connections	17
Features, std.	3	Shaft length	5
Formulas, Net Force	7-8	removal	10
Full Bridge	2, 3	Troubleshooting	14
Installation	4, 9	Typical Tensions	18
Linearity & Hysteresis combined	3	Web path	12
Load direction	3	Weight	3
Load ratings	3	Wheatstone bridge	2, 3
selection of	6	Wrap angle	5
Material	3	Zero	12
Mounting	5		
positions	7-8		
surface	5, 9		

DFE **DOVER FLEXP ELECTRONICS, INC.**
217 PICKERING ROAD
ROCHESTER, NEW HAMPSHIRE 03867-4630 U.S.A
TEL: 603-332-6150
FAX: 603-332-3758
E-mail: info@dfc.com Internet: www.dfc.com

CANADA

MEXICO

UNITED KINGDOM

EUROPE

TAIWAN

KOREA

AUSTRALIA

COLOMBIA

INDIA

CHILE