



# **INSTRUCTION MANUAL**

**Tension Roll<sup>®</sup> Transducer**

**MODEL TR**

**DOC 801-0648**

**5 YEAR WARRANTY**



**307 Pickering Road**

**Rochester, NH 03867-4630 U.S.A.**

For assistance, please call:

**TECHNICAL SERVICE** - Installations, Start-Up, Troubleshooting, Repairs, Field Service, Returns. **[techsupport@dfe.com](mailto:techsupport@dfe.com)**

**CUSTOMER SERVICE** - Replacement Parts, Individual Products, Questions about Orders, Manuals. **[customerservice@dfe.com](mailto:customerservice@dfe.com)**

**SALES** - Product Information, Systems Application Questions, and placing orders for standard products and special systems. **[sales@dfe.com](mailto:sales@dfe.com)**

Telephone: (603) 332-6150    Fax: (603) 332-3758

E-mail: [info@dfe.com](mailto:info@dfe.com)    Internet: [www.dfe.com](http://www.dfe.com)

# TABLE OF CONTENTS

---

<b>SECTION ONE</b>	<b>DESCRIPTION</b>	<b>PAGE</b>
1.1	General Description .....	1
1.2	Construction and Mechanical Operation .....	1
1.3	Electrical Operation .....	2
1.4	Specifications .....	3
1.5	Standard Features .....	3
1.6	Configuration Choices .....	3
1.7	Options .....	4
1.8	Accessories .....	4
<b>SECTION TWO</b>	<b>INSTALLATION</b>	
2.1	Dimensions .....	5
2.2	Pre-Installation Requirements .....	6
2.3	Installation Instructions .....	7
<b>SECTION THREE</b>	<b>CALIBRATION</b> .....	8
<b>SECTION FOUR</b>	<b>CARE AND MAINTENANCE</b> .....	9
<b>SECTION FIVE</b>	<b>TROUBLESHOOTING</b> .....	10
<b>APPENDICES:</b>	A. Transducer Electrical Connections .....	12
	B. Selection of Load Rating .....	13
	C. Typical Tensions .....	15
	Terms and Conditions .....	16
	Index .....	19

## LIST OF ILLUSTRATIONS

---

FIGURE:	1. View of Tension Roll .....	1
	2. Strain Gage Connections .....	2
	3. Dimensions .....	5
	4. Tension Zones .....	6
	5. TR Mounting Styles .....	7
	6. Tension Force Direction .....	7
	7. TR Electrical Connections .....	12
	8. Load Rating Selection Formulas .....	13

# SAFETY



This label indicates: "Read the manual"

Make sure you read and understand all instructions and safety precautions listed in this manual before installing or operating your DFE Tension Roll transducer. If you have any questions concerning the operation of your Tension Roll or the information in this manual, please contact us.

Email: [techsupport@dfc.com](mailto:techsupport@dfc.com)

Telephone: (603) 332-6150

- **Observe all warning labels.**
  - **Never remove warning labels.**
- 

Symbols used in this manual:



**WARNING** = This instruction must be followed to avoid a risk of death or serious injury

---



**WARNING:** During installation care should be taken not to drop the Tension Roll, handle the Tension Roll with care, sudden jolts or drops can damage its components and serious injury could result.



**WARNING:** When installing the Tension Roll must be mounted to allow for > 25mm of finger clearance.



**WARNING:** The isolated output is designed to prevent ground loops and noise. It is not intended or approved for safety isolation of hazardous voltages. Do not install unit where isolated circuit and chassis ground are more than 40Vpk differential.



**WARNING:** If this equipment is not connected or operated in the manner specified, the operating safety of this unit or of connected equipment cannot be guaranteed.



**WARNING:** Do not connect standard transducer Tension Roll to DFE Amplifiers having the Extended Range (XRE) option enabled. The transducers MAY be DAMAGED!

## 1.1 GENERAL DESCRIPTION

The Model "TR" Tension Roll<sup>®</sup> Transducer is an electro-mechanical device that converts web tension into a D.C. voltage which is proportional to tension. The voltage is amplified in external electronic circuitry and displayed on an analog or digital meter which is calibrated to indicate actual web tension, expressed in pounds, ounces, grams, kilograms, newtons or any other desirable units. The output voltage may also be supplied to a regulator circuit to control tension automatically.

The TR transducer is unique because it combines a dead-shaft idler roll with tension sensors built into each end of the roll.

The information in this Section will help give a clear understanding of the Model "TR" Transducer, how it works and how it is used.

## 1.2 CONSTRUCTION AND MECHANICAL OPERATION

In a typical installation, the transducer is mounted in the same way as any dead-shaft idler roll. No special provisions need to be made. The transducer shaft is available with plain ends for mounting in shaft hangers, drilled and tapped ends for mounting by thru-frame bolts, or milled flats with a bolt hole thru for mounting on the edge of machine frames. See Figure 5.

The roll is manufactured to industry standards for Total Indicated Runout (TIR), surface finish and taper. Every roll is dynamically balanced to specifications more stringent than the typical idler roll.

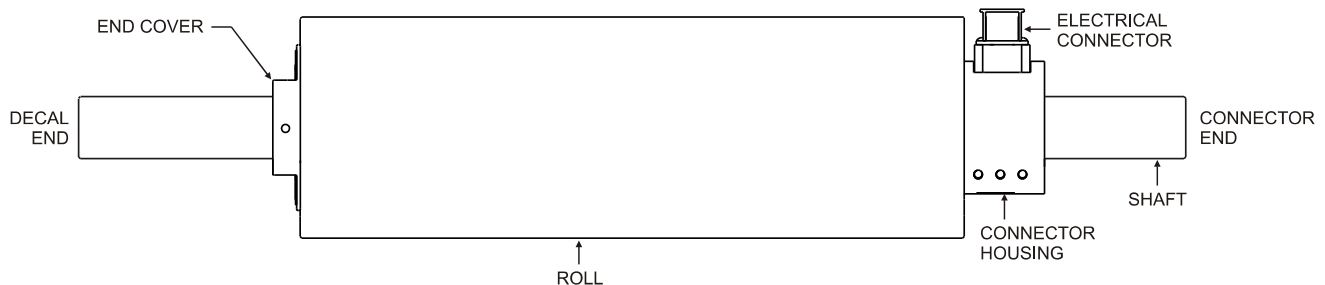

**Figure 1 - VIEW OF MODEL TR TRANSDUCER**

The Tension Roll<sup>®</sup> is designed to allow the roll to expand in length with rising temperature without causing any stress on the beams or bearings.

Inside the transducer are two dual cantilever beams, one at each end of the roll, with strain gages mounted on the top and bottom surfaces of each. The bearings are attached to the free end of each beam. When web tension is applied the beam deflects a small amount, causing an electrical output from the strain gages.

## 1.2 CONSTRUCTION AND MECHANICAL OPERATION *continued.*

The shaft acts as a mechanical stop, preventing damage from accidental overloads. The stop is functional thru 360 degrees, so the overload condition may occur from any direction, not just the load direction. In all cases, the beam is prevented from deflecting far enough to cause any damage.

The transducer is mounted on the machine frame by one of four methods; by shaft hangers, by bolts into the ends (shaft has drilled and tapped ends, or drilled and tapped with counter bore ends), or by radial bolts in each end (shaft has milled flats with bolt hole).

## 1.3 ELECTRICAL OPERATION (see Figure 2)

The Model "TR" Transducer has two tension sensors, one inside each end of the transducer roll. Web tension exerts a force on the roll which is transmitted to the cantilever beams by the bearings. Two semiconductor strain gages are mounted on the beam, one on the top and one on the bottom. As force is applied and the beam deflects, the top gage is stretched and the bottom gage is compressed. This increases the electrical resistance of the top gage and decreases the resistance of the bottom gage. The gages on both beams are electrically connected together in a Wheatstone bridge configuration. The bridge produces double the output of a single beam and averages the outputs so web position, width and loose or tight edges do not affect the accuracy of the tension signal.

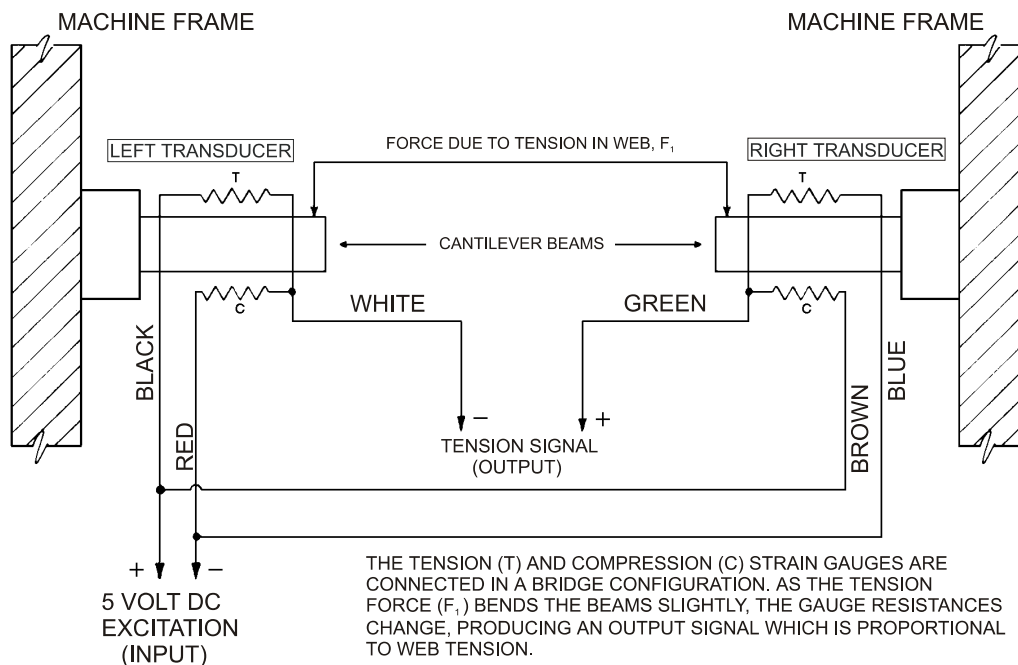

**Figure 2 - STRAIN GAGE CONNECTIONS**

The physical location of the strain gages, on opposite sides of the beam, ensures that each gage experiences the same temperature variations. This, and the Wheatstone bridge configuration, provides automatic temperature compensation and a stable output.

The strain gages are high output semiconductor devices which typically have an output sixteen times greater than the inexpensive foil gages used in some transducers. Therefore, the signal amplifier used with these Model TR transducers is a very stable low-gain design. An added benefit of the high output is inherent immunity to electrical noise.

## 1.4 SPECIFICATIONS

Excitation Voltage	.....	5 Vdc (10Vdc with XR option)	
Output	.....	500 mV, nominal, at 5V excitation (1V nom at 10Vdc)	
Strain Gages Resistance	.....	semiconductor, 100 ohms +/- 15 ohms	
Non-Repeatability	.....	± 1/4 % full span (FS)	
Non-Linearity and Hysteresis Combined	....	1/2 % (FS)	
Temperature Range	.....	-10° F to +200°F (-23° C to +93° C)	
Temperature Coefficient	.....	0.02% per degree F typical (0.036 % per ° C )	
Mating Electrical Connector:	.....	DFE Part No. 106-0050 for all sizes	
Electrical Connector Position	.....	6 o'clock (same as load direction)	
Connector Pin assignments	.....	Pin A = (WHT - decal end) = output,	
	.....	Pin B = (BLK - decal end) = + 5V,	
	.....	Pin C = (RED - decal end) = - 5V,	
	.....	Pin D = (GRN - connector end) = output,	
	.....	Pin E = (BLU - connector end) = - 5V,	
	.....	Pin F = (BRN - connector end) + 5V	
Roll: Material	.....	6061 aluminum, 304 stainless steel (option), 1020 Steel (option)	
	TIR	.....	0.002 inch (0.05 mm)
	Balance	.....	Quality grade G2.5 per ISO 1940 and ANSI S2-19-75
	Finish	.....	32 microinch
Shaft	.....	Stainless Steel	
Minimum Overload Capacity: Size 0, 1	.....	880 lbs. (3914 N)	
	Size 2	.....	3000 lbs (13334 N)
Deflection of Sensor Beam: Size 0, 1	.....	0.018 inch max (0.46 mm)	
	Size 2	.....	0.008 inch typical (0.2mm typical)
Standard Shaft Diameter Size 0, 1	.....	1.0 inch (25.4 mm)	
	Size 2	.....	1.125 inch (28.6 mm)
Shaft Size Tolerance (dia)	.....	nominal -0.002 inch ( -0.05mm)	
Load Ratings: Size 0	.....	12, 25, 50, 100 lbs. (55, 110, 225, 450 N)	
	Size 1	.....	12, 25, 50, 100, 150lbs. (55, 110, 225, 450, 670 N)
	Size 2	.....	12, 25, 50, 100, 200, 400 lbs. (55, 110, 225, 450, 900, 1800 N)

## 1.5 STANDARD FEATURES

- **One Integral Package.** Tension transducers and idler roll are combined into a single easy-to-install transducer roll.
- **Stainless Steel and Aluminum construction.** Excellent corrosion resistance.
- **One Transducer Cable.** No cable need cross the machine.

## 1.6 CONFIGURATION CHOICES

These are explanations of standard choices of various configurations that were specified for your application.

- **Size.** Sizes offered are Size 0, 1 and 2.
- **Roll Diameter.** Choice of: 2.25 inch for Size 0, 3 inch for Size 1, and 4 inch (std. for Size 2), 5 inch, or 6 inch for Size 2. Other diameters available, consult factory.
- **Roll Length:** Size 0: 6 inches to 40 inches. Size 1: 6 inches to 50 inches. Size 2: 7 inches to 120 inches. Longer rolls available, consult factory. See table in Section 2.2.1.1 for more information.
- **Shaft Length.** Measured for application and length of roll required. See Section 2.2.1.1 for more information.
- **Load Ratings.** Size 0: 12, 25, 50, 100 lbs. (55, 110, 225, 450 N)  
Size 1: 12, 25, 50, 100, 150 lbs. (55, 110, 225, 450, 670 N)  
Size 2: 12, 25, 50, 100, 200, 400 lbs. (55, 110, 225, 450, 900, 1800 N)

- **Connector Position.** Choices are as follows: 6:00 (std.), 12:00.

## 1.7 OPTIONS

- **Counterbore, Drill and Tap (CDT).** Shaft ends are counterbored and drilled and tapped.
- **Drill and Tap (D&T).** Drill and tap ends of shaft. **Size 0 and 1:** 5/16-18 (8mm), **Size 2:** 1/2-13 (12mm)
- **Extended Range Output (XR).** Extra sensitive at low tensions. Electronics must have extended range also.
- **Milled Flats (MF).** Shaft with milled flats and a through hole at each end.
- **Non-standard Shaft Extensions (NSE).** Shaft extends unequal lengths on ends. Specify lengths.
- **Oiled Bearings (OB).** Oil instead of grease for lubrication. **Not recommended by DFE and will void warranty.**
- **Reduced Diameter 3/4" (RD3).** Diameter of shaft is reduced to 3/4". Used on TR0, and TR1 having 1" shafts.
- **Steel Roll (SR),** or **Stainless Steel (SSR)** instead of standard aluminum roll.

## 1.8 ACCESSORIES

- Shaft Hangers. Size 0 and 1: #601-3118. Size 2: #601-1179



## 2.1 DIMENSIONS

inches (mm)

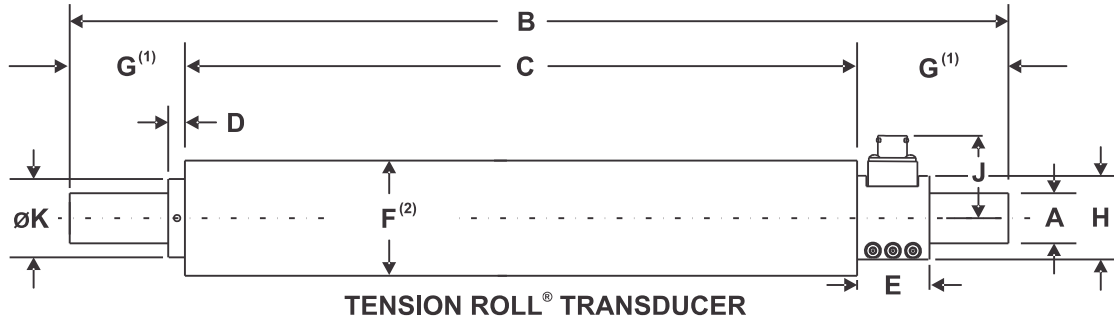

TENSION ROLL® TRANSDUCER

		A	B	C	D	E	F <sup>(2)</sup>	G	H	J	K
SIZE 0	in.	Ø 1.00	*	*	0.31	1.30	Ø 2.25	3.00	2.20	1.98	1.56
	mm	Ø 25.4	*	*	7.9	33	Ø 57.1	76.2	55.9	50.3	39.6
SIZE 1	in.	Ø 1.00	*	*	0.31	1.26	Ø 3.00	3.00	2.40	2.11	1.56
	mm	Ø 25.4	*	*	7.9	32	Ø 76.2	76.2	61	53.6	39.6
SIZE 2	in.	Ø 1.125	*	*	0.31	1.26	Ø 4.00	4.00	2.40	2.11	1.72
	mm	Ø 28.58	*	*	7.9	32	Ø 101.6	101.6	61	53.6	43.7

\* Specified at time of order

Notes: <sup>(1)</sup>Can be changed upon request. <sup>(2)</sup>Size 2 is available with Ø 4.00" standard roll or optional Ø 5.00" (Ø 127) or Ø 6.00" (Ø 152.4) roll.

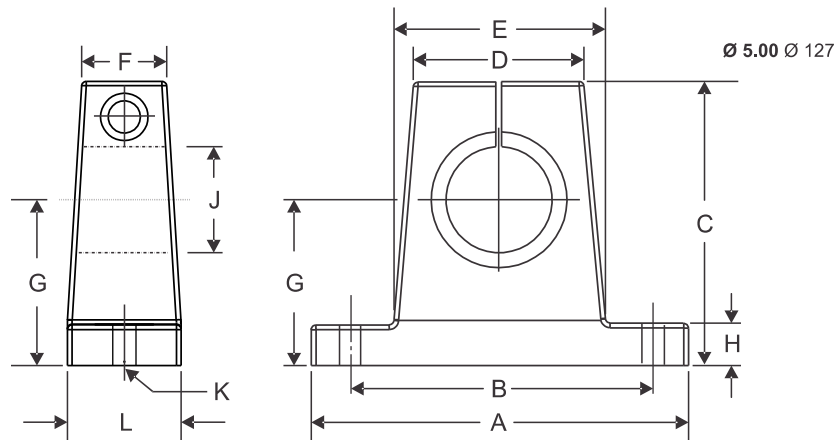

SHAFT HANGERS FOR TRANSDUCERS

		A	B	C	D	E	F	G	H	J	K	L
SIZE 0 (#601-3118)	in.	4.00	3.00	3.00	1.84	2.20	0.80	1.75	0.43	Ø 1.00	Ø 0.34	1.18
	mm	101.6	76.2	76.2	46.7	56	20.3	44.45	10.9	Ø 25.4	Ø 8.6	29.9
SIZE 1 (#601-3118)	in.	4.00	3.00	3.00	1.84	2.20	0.80	1.75	0.43	Ø 1.00	Ø 0.34	1.18
	mm	101.6	76.2	76.2	46.7	56	20.3	44.45	10.9	Ø 25.4	Ø 8.6	29.9
SIZE 2 (#601-1179)	in.	4.00	3.00	3.00	1.84	2.20	0.80	1.75	0.43	Ø 1.125	Ø 0.34	1.18
	mm	101.6	76.2	76.2	46.7	56	20.3	44.45	10.9	Ø 28.58	Ø 8.6	29.9

Figure 3 - DIMENSIONS

## 2.2 PRE-INSTALLATION REQUIREMENTS

1. **TRANSDUCER ROLL.** Please Note! There can be no brakes, clutches, belts, chains or gears attached to the TR transducer roll or shaft. It can not be a nip roll or be in contact with a nip roll. **NOTHING MUST CONTACT THE ROLL OR ITS SHAFT EXCEPT THE WEB!**

1. **Roll Width** The face width of the roll is normally the same as the other rolls in the machine. However in some cases, **Dover Flexo Electronics** may require a longer face width in order to reduce the length of the shaft extensions. Following are the standard lengths of shaft extensions per end for the various sizes: Size 0,1 = 3 inches per end, and Size 2 = 4 inches per end, These lengths were chosen to minimize shaft deflection.

The maximum roll face width is usually limited by deflection of the roll caused by web tension. Too much deflection will cause problems with the web such as wrinkling. Refer to table below for the maximum available roll face widths.

TR	MAX. ROLL WIDTH inch (mm)
SIZE 0	40 (1016)
SIZE 1	50 (1270)
SIZE 2	120 (3048)

2. **TENSION ZONE.** The transducer must be located in the tension zone which is to be monitored or controlled. The beginning or end of any tension zone is always at a nip (driven or braked), unwind shaft, rewind shaft or drag bar. Any element in the web path that can change web tension is at one end of a tension zone.

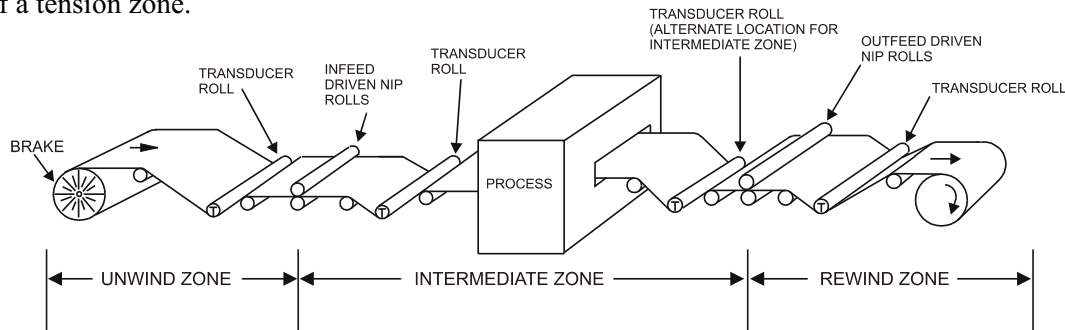
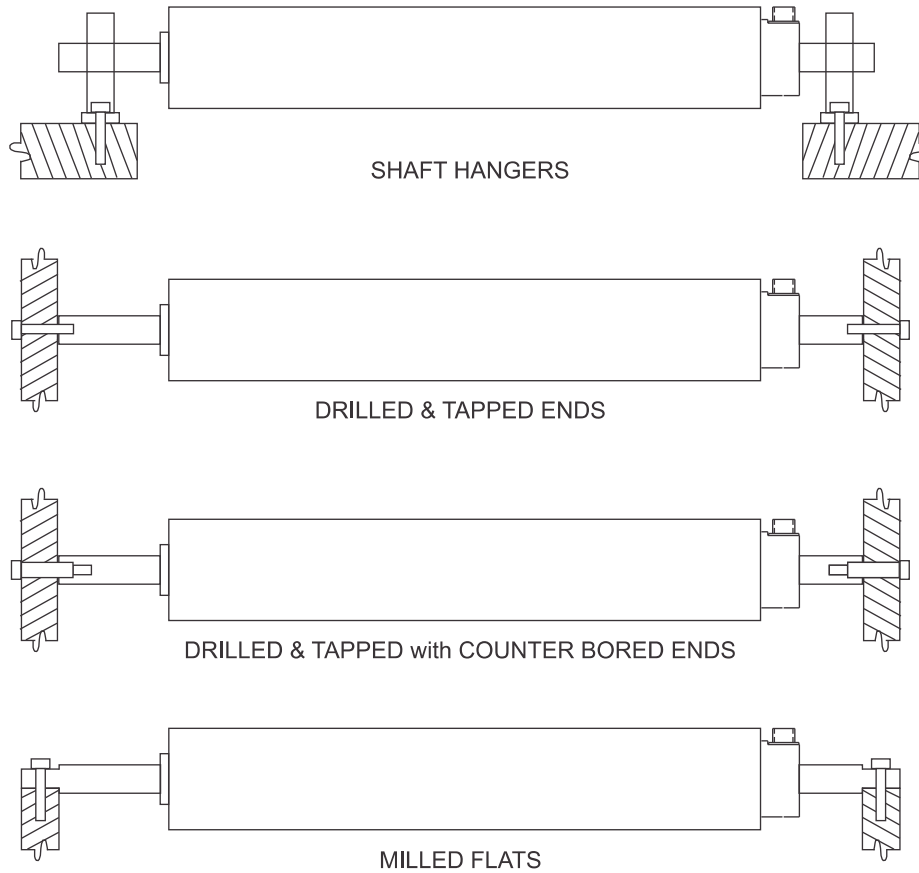

**Figure 4 - TENSION ZONES**

3. **WRAP ANGLE.** The web must always contact the transducer roll in exactly the same way. The wrap angle must not change as the unwind or rewind roll diameter changes. Therefore there must be at least one idler roll between the transducer and the unwind or rewind shaft. If the machine has more than one webbing path, be sure to choose a location that is wrapped the same for each. Otherwise it will be necessary to install an additional transducer, or dual calibration circuitry, or both. If the wrap angle is allowed to change, the transducer output will change with angle as well as tension, and accuracy will be reduced.

4. **MOUNTING SURFACE.** The structure on which the transducer is mounted should be strong. Any movement of the structure may cause the transducer to become mis-aligned. This probably will not affect the transducer's performance but it could cause the web to shift toward one side when it goes over the roll.

#### 4. MOUNTING SURFACE *continued..*

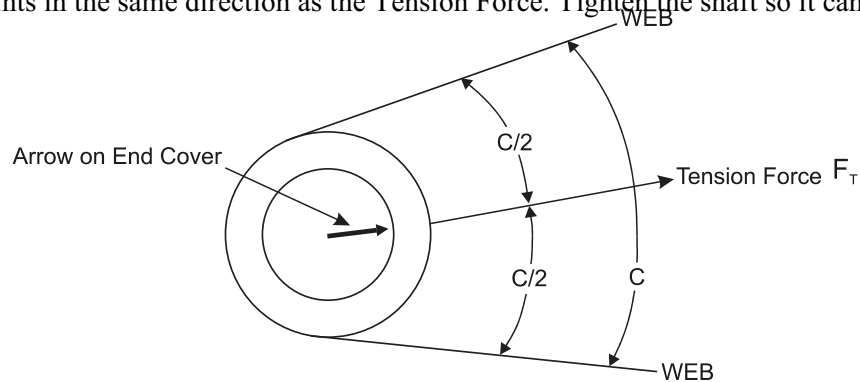

**Figure 5 - MOUNTING STYLES**

### 2.3 INSTALLATION INSTRUCTIONS

The Model "TR" Transducer is very easy to install. Follow the same procedure as you would for any dead-shaft idler roll. The roll can rotate in either direction.

1. **VERIFY THE SHAFT LENGTH** Measure the distance between the machine frames where the transducer will be mounted to verify that the shaft length is correct.
2. **ORIENT THE TRANSDUCER (see figure 6)** The transducer shaft must be turned so the Tension Force arrow points in the same direction as the Tension Force. Tighten the shaft so it can not turn.



**Figure 6 - TENSION FORCE DIRECTION**

*NOTE:* During installation and handling, be careful not to drop the transducer on its end. Damage could result.

**3. ATTACH CABLE.** Make sure cable does not get near the moving roll or web.

## **SECTION 3**

## **CALIBRATION**

---

There are no calibration adjustments on the Model "TR" Transducer itself. See instruction manual provided with the electronics purchased.

## **SECTION 4**

## **CARE AND MAINTENANCE**

---

Your Dover Flexo Tension Roll<sup>®</sup> Transducer has been manufactured of quality materials. With proper application and installation your transducers will be relatively maintenance free and long lasting.

Any changes in your application which affect the dynamics of your equipment such as web speed, net force, material, etc. could possibly require upgrading of load rating or roll change. Contact Dover for specific information and engineering approval.

### **DOVER FLEXO ELECTRONICS**

**Telephone: 603-332-6150 Fax: 603-332-3758**

**E-mail: [techsupport@dfc.com](mailto:techsupport@dfc.com) Internet: [www.dfc.com](http://www.dfc.com)**

This is a list of problems which could occur during initial start-up or afterwards. The probable causes are listed with the most likely one first and the least likely one last.

**1. TRANSDUCER ROLL SHAKES, VIBRATES or BOUNCES**

- a. Roll is not balanced.
- b. Transducer mounting bolts are not tight.
- c. Roll is turning at its natural frequency. Call **DOVER** for analysis of operating conditions and solution to problem.

**2. CAN NOT ADJUST TENSION METER TO READ ZERO WHEN WEB IS SLACK**

- a. Transducer roll is too heavy. See Appendix B, Step 4, page 14.
- b. Failure in the tension indicator circuit.

**3. TENSION METER READS BACKWARDS**

- a. Transducer is installed backwards with force arrow pointing in opposite direction. See Section 2.3 page 7.
- b. Transducer cable is connected wrong at controller/indicator terminal strip. Signal wires are reversed.

**4. TENSION METER NEEDLE PEGS HIGH OR LOW**

- a. Meter is not electrically adjusted to zero. See instruction manual provided with electronics.
- b. Transducer cable has broken wire, poor connection or short circuit.
- c. A strain gage has failed. To verify: Unplug the transducer cable and use an ohm-meter to measure the resistance of the gages at the connector on the transducer. Measure between pins A,B, and A,C. Also measure between pins D,E and D,F. In each case the resistance should be about 100 ohms. Measure the resistance between any pin and the shaft of the transducer. The meter should read infinite resistance. Apply a force to the roll by hand or by using a rope and a weight, in the direction of the tension force and maintain it while again measuring between pins A,B and A,C. Repeat while measuring between pins D,E and D,F. The resistance should be only a few ohms different from before.
- d. Failure in the tension amplifier circuit of the controller/indicator.

**5. TENSION METER DOES NOT READ ZERO WHEN WEB IS SLACK AND READING DRIFTS WITH TIME.**

- a. Meter is not calibrated. See instruction manual provided with electronics.
- b. Transducer cable has a broken wire, poor connection, ground or short circuit.
- c. A strain gage is cracked. Perform the test in 4.c. above.

**6. TENSION METER DOES NOT READ THE SAME EACH TIME THE SAME FORCE IS APPLIED (Poor repeatability)**

- a. Extreme build-up of dirt, ink, adhesive, grease or other foreign material inside end of roll causing interference with beam movement.
- b. Transducer cable has a broken wire, poor connection, ground or short circuit.
- c. Strain gage failure. See 4.c. above for test.

**7. TENSION METER READING DOES NOT CHANGE WHEN FORCE IS APPLIED TO ROLL. METER READS ZERO.**

- a. Meter is not calibrated. See instruction manual provided with electronics.
- b. Transducer roll is too heavy. See Appendix B, Step 4, page 14.
- c. Extreme build-up of dirt, ink, adhesive, grease or other foreign material inside end of roll causing interference with beam movement.
- d. Transducer cable has broken wire, poor connection, ground or short circuit.
- e. Transducer cables connected incorrectly, or to wrong transducers.
- f. Failure of tension amplifier circuit in controller/indicator. Unit not turned on.

**8. TENSION METER NEEDLE BOUNCES**

- a. Web tension is fluctuating because of machine speed fluctuations, bent roll shafts, worn idler roll bearings, chattering unwind brake, flat spot in unwind or rewind roll, etc.
- b. Transducer mounting bolts are loose.
- c. Tension controller is not adjusted properly. See controller Instruction Manual for procedure.

## TENSION ROLL (TR) AND NARROW WEB (NW) TRANSDUCERS

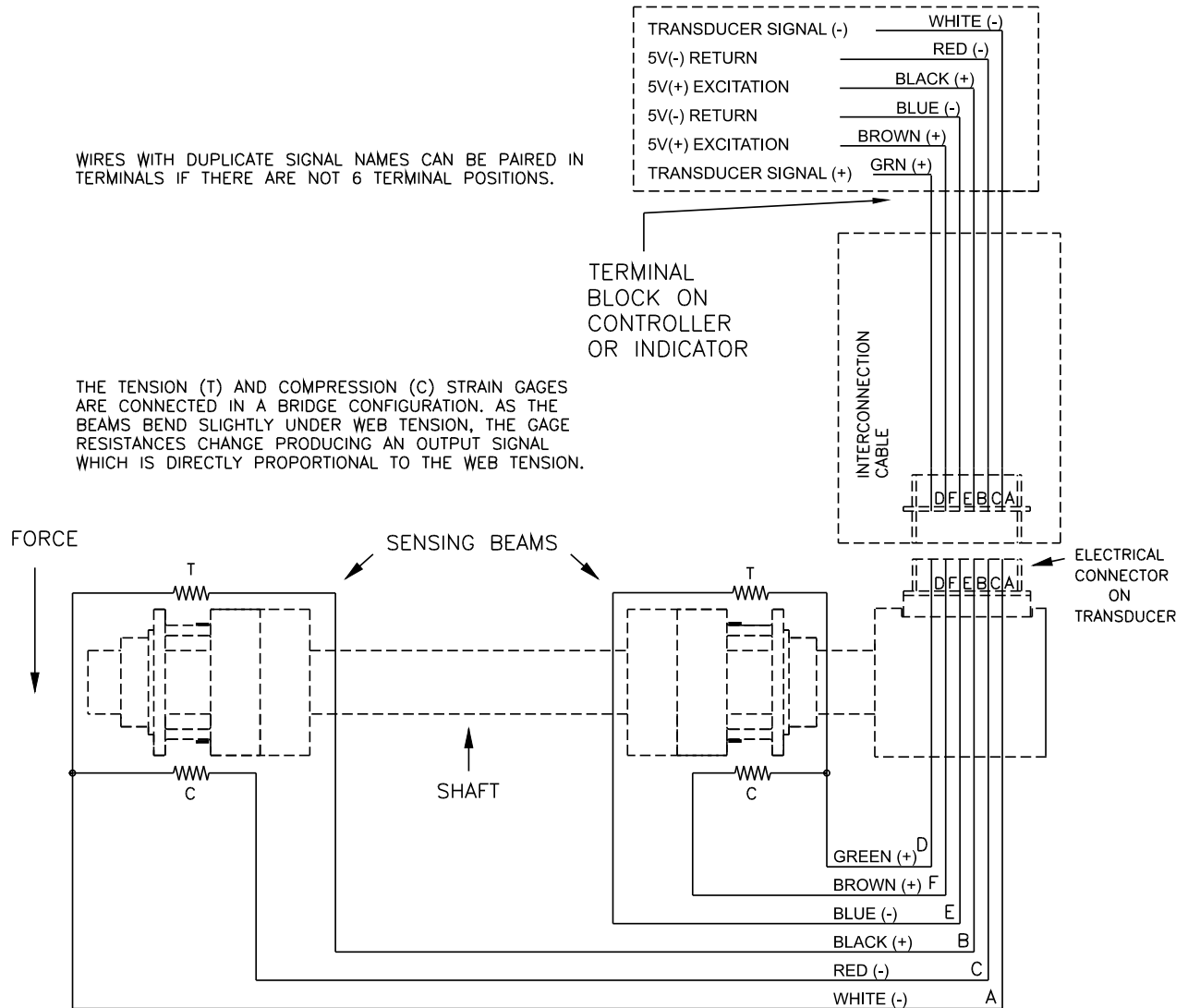

**Figure 7 - TR TRANSDUCER ELECTRICAL CONNECTIONS**



## SELECTION OF LOAD RATING

**1. LOAD RATINGS.** The Model "TR" Transducer is available in several standard load ratings, ranging from 12 lbs. to 400 lbs. The correct rating for any particular application depends on web tension, transducer roll weight, wrap angle and the direction of the tension force on the transducer roll. Figure 5 contains mathematical formulas which use these factors to determine the correct load rating.

**2. SELECTION PROCEDURE** The correct load rating is found in four simple steps:

**Step 1. OBTAIN DATA TO PLUG INTO THE SELECTION FORMULA**

- Compute the weight of the transducer roll and bearing assemblies. Refer to the table in Step 4 on the next page for roll and bearing weights.
- Estimate the maximum web tension. Use Appendix C, Typical Tensions, as a guide if necessary.
- Determine the wrap angle.
- Determine the angle of the tension force,  $F_T$ , relative to the vertical. (**NOTE:**  $F_T$  bisects the wrap angle)

**Step 2. COMPUTE NET FORCE USING THE SELECTION FORMULA**

Refer to Figure 8. Select the appropriate wrap configuration as determined by the direction of the tension force (above, below or on horizontal). Compute the Net Force, using the formula below the wrap diagram.

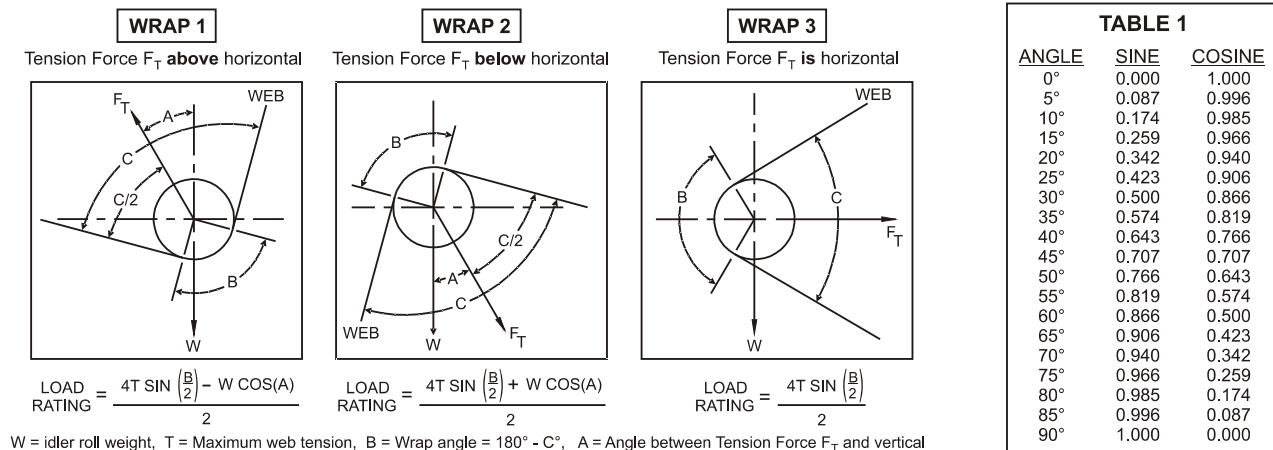

**Figure 8 - LOAD RATING SELECTION FORMULAS**

**Step 3. SELECT THE LOAD RATING**

Use the Load Rating Chart below to select the correct load rating. In some cases, the load rating may be **LESS** than the computed Net Force. This is acceptable because the Net Force formula contains an oversizing factor of 2. Therefore the actual force exerted on the transducer will not exceed its rating, if the transducer is chosen according to the chart.

LOAD RATING CHART			
NET FORCE -lbs. (N)		LOAD RATING - lbs. (N)	
up to 15	(66)	12	(55)
16 - 32	(71 - 142)	25	(110)
33 - 63	(146 - 280)	50	(225)
64 - 125	(284 - 556)	100	(450)
94 - 188	(426 - 834)	150	(670)
126 - 250	(560 - 1112)	200	(900)
251 - 500	(1116 - 2224)	400	(1800)

#### Step 4. COMPARE LOAD RATING WITH EFFECTIVE TRANSDUCER ROLL WEIGHT

Sometimes, a Tension Roll shell is so heavy that its weight uses up most of the operating range of the transducer. When this happens, it may not be possible to adjust the tension indicating meter to read zero when tension is zero because the adjustment range of the electronic circuit has been exceeded. To find out if the roll is too heavy, compare the load rating with the effective weight of the roll as follows:

Refer back to the Net Force formula used in Step 2. The effective roll weight is the "W Cos(A)" term in the formula. If W Cos(A) is more than 95% of the load rating chosen, the tension meter will probably not be adjustable to zero. If this is the case, one or more of the following changes must be made to reduce W Cos(A) to less than 95% of the load rating:

- A. Reduce the roll weight by using a smaller diameter roll. This may not be possible due to strength considerations.
- B. Increase angle A. (see Figure 8)
- C. Use the next higher load rating.

SIZE 0	ALUMINUM		STEEL		STAINLESS STEEL	
	Roll Diameter - inch (mm)		Roll Diameter - inch (mm)		Roll Diameter - inch (mm)	
	2.25 (57)		2.25 (57)		2.25 (57)	
Roll Weight lb./in. (kg/cm)	0.16 (0.03)		0.45 (0.08)		0.45 (0.08)	
Weight of Bearing Assemblies is <b>0.3 lbs.</b> (0.136 kg) total. Minimum Width of roll is <b>6 inches</b> (152mm)						
SIZE 1	ALUMINUM		STEEL		STAINLESS STEEL	
	Roll Diameter - inch (mm)		Roll Diameter - inch (mm)		Roll Diameter - inch (mm)	
	3 (76)		3 (76)		3 (76)	
Roll Weight lb. / in. (kg/cm)	0.30 (0.054)		0.88 (0.157)		0.88 (0.157)	
Weight of Bearing Assemblies is <b>1.4 lbs.</b> (0.63 kg) total. Minimum Width of roll is <b>6 inches</b> (152mm)						
SIZE 2	ALUMINUM			STEEL or STAINLESS STEEL		
	Roll Diameter - inch (mm)			Roll Diameter - inch (mm)		
	4 (102)	5 (127)	6 (152)	4 (102)	5 (127)	6 (152)
Roll Weight lb. / in. (kg/cm)	0.54 (0.096)	0.69 (0.123)	0.85 (0.152)	1.56 (0.279)	2.00 (0.358)	2.44 (0.437)
Weight of Bearing Assemblies is <b>4.3 lbs.</b> (1.9 kg.) total. Minimum width of roll is <b>7 inches</b> (178 mm).						

NOTES: 1. Roll may be too heavy for load rating. Be sure to check the sizing criteria and formulas. 2. Use the standard sizing formulas to determine the correct load rating. In the formulas, "W" is equal to the roll weight plus the weight of the bearing assemblies. 3. Normally, maximum roll width is limited to 120 inches by our machine shop capacity. Shorter widths are to limit roll deflection. Wider rolls are available on special order at additional cost. Consult factory.

# Appendix C: Typical Tensions for Various Materials

## TYPICAL TENSIONS FOR WEB MATERIALS

ACETATE		0.5 lb. per mil per inch of width	
FOIL	Aluminum	0.5 lb. per mil per inch of width	
	Copper	0.5 lb. "	
CELLOPHANE		0.75 lb. per mil per inch of width	
NYLON		0.25 lb. per mil per inch of width	
PAPER	15 lb *	0.4 lb. per inch of width	
	20 lb	0.5 lb. "	
	30 lb	0.75 lb. "	
	40 lb	1.25 lb. "	
	60 lb	2.0 lb. "	
	80 lb	3.0 lb. "	
	100 lb	4.0 lb. "	
* based on 3000 sq. ft. ream			
PAPERBOARD	8pt	3.0 lb. per inch of width	
	12pt	4.0 lb. "	
	15pt	4.5 lb. "	
	20pt	5.5 lb. "	
	25pt	6.5 lb. "	
	30pt	8.0 lb. "	
POLYETHYLENE		0.12 lb. per mil per inch of width	
POLYESTER (Mylar)		0.75 lb. per mil per inch of width	
POLYPROPYLENE		0.25 lb. per mil per inch of width	
POLYSTYRENE		1.0 lb. per mil per inch of width	
RUBBER	<u>GAUGE</u>	<u>AT 25% STRETCH</u>	<u>AT 50% STRETCH</u>
	10 mil	1.75	3.68
	12 mil	1.10	2.03
	16.5 mil	4.09	8.17
	26 mil	2.47	4.97
SARAN		0.15 lb per mil per inch of width	
STEEL	<u>GAUGE - INS</u>	<u>UNWIND-PSI</u>	<u>REWIND-PSI</u>
	0.001 - 0.005	1000	4000
	0.006 - 0.025	850	3500
	0.026 - 0.040	750	3000
	0.041 - 0.055	650	2600
	0.058 - 0.070	550	2200
	0.071 - 0.090	450	1800
	0.091 - 0.120	450	1400
	0.121 - 0.140	400	1200
	0.141 - 0.165	400	1000
	0.166 - 0.200	400	900
	0.201 - 0.275	400	800
	0.276 - 0.380	300	700
VINYL		0.05 lb. per mil per inch of width	

\*\*\* For laminated webs, sum the tension for the individual webs and add 0.1 lb per inch of width.

# TERMS AND CONDITIONS OF SALE AND SHIPMENT

## 1. THE COMPANY

Dover Flexo Electronics, Inc. is hereinafter referred to as the Company.

## 2. CONFLICTING OR MODIFYING TERMS

No modification of, additions to or conflicting provisions to these terms and conditions of sale and shipment, whether oral or written, incorporated into Buyer's order or other communications are binding upon the Company unless specifically agreed to by the Company in writing and signed by an officer of the Company. Failure of the Company to object to such additions, conflicts or modifications shall not be construed as a waiver of these terms and conditions nor an acceptance of any such provisions.

## 3. GOVERNING LAW

This contract shall be governed by and construed according to the laws of the state of New Hampshire, U.S.A. The parties agree that any and all legal proceedings pursuant to this contract shall take place under the jurisdiction of the courts of the State of New Hampshire in the judicial district of Strafford County.

## 4. PENALTY CLAUSES

Penalty clauses of any kind contained in orders, agreements or any other type of communication are not binding on the Company unless agreed to by an officer of the Company in writing.

## 5. WARRANTY

Dover Flexo Electronics, Inc. warrants, to the original Buyer, its' products to be free of defects in material and workmanship for five years from date of original shipment. Repairs on products are warranted for 90 days from date of shipment. During the warranty period the Company will repair or replace defective products free of charge if such products are returned with all shipping charges prepaid and if, upon examination, the product is shown to be defective. This warranty shall not apply to products damaged by abuse, neglect, accident, modification, alteration or mis-use. Normal wear is not warranted. All repairs and replacements under the provisions of this warranty shall be made at Dover Flexo Electronics or at an authorized repair facility. The Company shall not be liable for expenses incurred to repair or replace defective products at any other location or by unauthorized persons or agents. This warranty contains all of the obligations and warranties of the Company. There are no other warranties, either expressed or implied. No warranty is given regarding merchantability or suitability for any particular purpose. The Company shall not be liable in either equity or law for consequential damages, losses or expenses incurred by use of or inability to use its' products or for claims arising from same. No warranty is given for products of other manufacturers even though the Company may provide these products with its' own or by themselves. The provisions of this warranty can not be changed in any way by any agent or employee of the Company. Notice of defects must be received within the warranty period or the warranty is void. The warranty is void if the serial number tag is missing or not readable.

## 6. PAYMENTS

Standard terms of credit are net 30 days from date of shipment, providing satisfactory credit is established with the Company. Amounts past due are subject to a service charge of 1.5% per month or portion thereof or 18% per annum. The Company reserves the right to submit any unpaid late invoices to a third party for collection and Buyer shall pay all reasonable costs of such collection in addition to the invoice amount. All quoted prices and payments shall be in U.S. Dollars.

If the Company judges that the financial condition or payment practices of the Buyer does not justify shipment under the standard terms or the terms originally specified, the Company may require full or partial payment in advance or upon delivery. The Company reserves the right to make collection on any terms approved in writing by the Company's Finance Department. Each shipment shall be considered a separate and independent transaction and payment therefore shall be made accordingly. If the work covered by the purchase order is delayed by the Buyer, upon demand by Company payments shall be made on the purchase price based upon percentage of completion.

## 7. TAXES

Any tax, duty, custom, fee or any other charge of any nature whatsoever imposed by any governmental authority on or measured by any transaction between the Company and the Buyer shall be paid by the Buyer in addition to the prices quoted or invoiced.

## 8. RETURNS

Written authorization (MRA) must be obtained from the Company's factory before returning any material for which the original Buyer expects credit, exchange, or repairs. Material returned for credit must be unused, received back within 30 days of original ship date and shall be subject to a re-stocking charge of 15%. Special Product Requests (SPRs), product manufactured specially to customer specifications, and non-DFE product purchased on customer behalf shall not be returnable for any reason. All material returned, for whatever reason, shall be sent with all freight charges prepaid by the Buyer.

## 9. SHIPPING METHOD AND CHARGES

All prices quoted are EXW the Company's factory. The Company shall select the freight carrier, method and routing. Shipping charges are prepaid and added to the invoice of Buyers with approved credit, however the Company reserves the right to ship freight-collect if it prefers. Shipping charges will include a charge for packaging. Company will pay standard ground freight charges for items being returned to Buyer which are repaired or replaced under the Warranty. Claims of items missing from a shipment must be received, in writing, within 30 days of original shipment

## 10. CANCELLATION, CHANGES, RESCHEDULING

Special Product Requests (SPRs), product manufactured specially to customer specifications, and non-DFE product purchased on customer behalf shall not be returnable for any reason. Buyer will be subject to a 15% fee for any standard item on order with the Company which is cancelled by the Buyer. A one-time hold on any item ordered from the Company shall be allowed for a maximum of 30 days. After 30 days, or upon notice of a second hold, Company shall have the right to cancel the order and issue the appropriate cancellation charges which shall be paid by Buyer. Items held for the Buyer shall be at the risk and expense of the Buyer unless otherwise agreed upon in writing. Company reserves the right to dispose of cancelled material as it sees fit without any obligation to Buyer. If Buyer makes, or causes to make, any change to an order the Company reserves the right to change the price accordingly.

## 11. PRICES

Prices published in price lists, catalogs or elsewhere are subject to change without notice and without obligation. Written quoted prices are valid for thirty days only.

## 12. EXPORT SHIPMENTS

Payment for shipments to countries other than the U.S.A. and Canada or to authorized distributors shall be secured by cash in advance or an irrevocable credit instrument approved by an officer of the Company. An additional charge will apply to any letter of credit. There will also be an extra charge for packaging and documentation.

## 13. CONDITION OF EQUIPMENT

Buyer shall keep products in good repair and shall be responsible for same until the full purchase price has been paid.

## 14. OWNERSHIP

Products sold are to remain the property of the Company until full payment of the purchase price is made.

Rev.10 10/15/19

# NOTES

---

# NOTES

---

# INDEX

Accessories . . . . .	4	Repeatability . . . . .	3
Balance, dynamic . . . . .	1, 3	Roll	
Beam . . . . .	1, 3	material . . . . .	3, 14
Calibration . . . . .	8	precautions . . . . .	6
Dead shaft . . . . .	1	weight . . . . .	7, 13
Deflection . . . . .	3	width . . . . .	5, 6
Description . . . . .	1	Shaft	
Dimensions . . . . .	5	diameter . . . . .	5
Direction of rotation . . . . .	7	ends . . . . .	4, 7
Effective roll weight . . . . .	14	length . . . . .	3, 5
Electrical connections . . . . .	2, 3, 12	material . . . . .	3
Electrical connector . . . . .	1, 12	Shaft hanger . . . . .	4, 5, 7
operation . . . . .	2	Specifications . . . . .	3
part number of mating part . . . . .	3	Strain gage . . . . .	2, 3
positions available . . . . .	3	Temperature	
Excitation voltage . . . . .	2, 3, 12	coefficient . . . . .	3
$F_T$ (see Tension force)		range . . . . .	3
Gage (see Strain gage)		Tension force . . . . .	2, 7, 13
Gap, overload stop . . . . .	2	Tensions, typical . . . . .	15
Hysteresis . . . . .	3	Tension zones . . . . .	6
Installation . . . . .	5 - 7	Terms and conditions of sale . . . . .	16
Load rating		Transducer location . . . . .	6
selection of . . . . .	13	Troubleshooting . . . . .	10
sizes . . . . .	3, 13	Warranty . . . . .	16
Mechanical Operation . . . . .	1	Wheatstone bridge . . . . .	2
Mis-alignment . . . . .	6	Wrap angle . . . . .	13
Mounting styles . . . . .	7	Zone (see Tension zone) . . . . .	6
Net force . . . . .	13		
Non-Linearity . . . . .	3		
Options . . . . .	4		
Output . . . . .	2, 3, 12		
Overload . . . . .	3		
capacity . . . . .	3		
stop . . . . .	3		



307 PICKERING ROAD  
ROCHESTER, NEW HAMPSHIRE 03867-4630 U.S.A  
TEL: 603-332-6150  
FAX: 603-332-3758  
E-mail: [info@dfc.com](mailto:info@dfc.com) Internet: [www.dfc.com](http://www.dfc.com)

CANADA

MEXICO

UNITED KINGDOM

TAIWAN

KOREA

AUSTRALIA

SOUTH AFRICA

CHINA