



MODEL VNW SERIES TENSION TRANSDUCER



The VNW (Very Narrow Web) transducer combines the robustness of DFE's Model C transducer with the choice of mounting styles and wheel options from the cantilevered RFA load cell design. Typical applications include wire, plastic, rubber, metal, glass and other flexible substrates. The VNW's maximum 400 lb load rating extends its measurement capability beyond the RFA's limit of 150 lbs, allowing for higher tension applications such as steel belt and tire cord.

The VNW transducer's standard configuration incorporates an aluminum beam with a stainless steel housing and shaft holder. The five mounting styles offered are: Screw, Flange, Pillow-Block, Piloted-Flange and Through-Frame.

The VNW load cell is cantilever-mounted on process machinery for unwind, payoff, rewind, take-up, or intermediate zone applications. Tension is measured by high-output semiconductor strain gages housed internally

on a dual-cantilevered transducer beam and connected in a wheatstone bridge configuration. Wheels are shaft-mounted with the shaft inserted into the transducer's bore and secured by set screws. The shaft insertion depth can be adjusted (+/- 0.25 inch) for proper alignment of the wheel with the web or filament.

As the ribbon or filament passes over the rotating transport wheel, the force of the substrate on the wheel shaft causes a minute deflection of the transducer beam. The resulting change in strain gage resistance yields a voltage output from the transducer that is proportional to tension. The transducer output is then conditioned by a DFE amplifier, indicator or automatic tension controller for tension measurement or complete closed-loop tension control (incorporating a torque device).

The standard electrical connector is positioned at 6 o'clock (inline with force) but other positions can be specified relative to the force direction.

FEATURES & BENEFITS

- 2 1/8" depth allows for installation in tight spaces.
- Highly accurate and reliable semiconductor strain gage technology.
- Versatile and easy-to-install.
- Wheel face lengths to 4" maximum.
- High performance design and materials for long life.
- Load Ratings from 10 – 400 lbs (45 – 1,779N) with wide operating range.
- Special wheels are available.
- Accurate tension measurement of any narrow web, ribbon or filament.
- Improved product quality and consistency from any web or filament process.
- Stainless steel and aluminum construction for excellent corrosion resistance.
- Reduced material waste.
- Higher production with less downtime.
- 5 year tension-free warranty.

OPTIONS

Metric Mounting Stud (MMS) - Metric mounting screw for S type transducers.

Extended Range Output (XR) - Increased sensitivity when used with legacy amplifiers and indicators such as the TI14, TI15, TI17, TI18, TI23 & TI24.

ACCESSORIES

Wheel Assemblies: Hardcoat anodized aluminum wheels available in 3 types:

Ribbon Wheels available in 1", 2", 3" and 4" widths; **Filament Wheel; Adapter Wheel** hub for mounting a custom wheel or pulley.

Shaft Assembly: No wheel included. Shaft and spacer with two bearings.

PRODUCT CODE

You may order by description or by specifying the code by matching each labeled place with one of the choices below. **Example: VNW2-S-50-12-MMS**

VNW X - X - X - X - (separated by commas)

SIZE	MOUNTING STYLE	LOAD RATING	CONNECTOR POSITION	OPTIONS
2	S = Screw / Bolt PB = Pillow Block FL = Flange TF = Through-Frame PFL = Piloted Flange	10 lbs ³ 25 lbs 50 lbs 100 lbs 200 lbs 400 lbs	6 (6:00) 12 (12:00) Rear (PB, TF ² , PFL only)	MMS = Metric Mounting Stud XR = Extended Range ¹ Z = Special (SPR)

- NOTES:**
1. Requires amplifier, indicator or controller to have XRE option enabled.
 2. Use rear connector position for TF mounting style.
 3. 4" ribbon wheel requires 25 lbs or higher load rating.

SPECIFICATIONS:

ELECTRICAL

Excitation: 5 VDC max (Std)
10 VDC max (XR Option)

Output: 100 mV/V, nominal

Strain Gages: Semiconductor, 100 ohms, nominal

Circuit Configuration: Full Wheatstone Bridge

Non-Repeatability: $\pm 1/4\%$ full span (FS)

Combined Non-Linearity and Hysteresis: $\pm 1/2\%$ (FS)

Temperature Range: -10°F to 200°F (-23°C to 93°C)

Temperature Coefficient: 0.02% FS per $^{\circ}\text{F}$, typical
(0.036% FS per $^{\circ}\text{C}$)

Mating Electrical Connector: Mil Spec - PT06E10-6S

Connector Pin Assignment:

A = Signal Output (-)	D = Signal Output (+)
B = Excitation (+)	E = Excitation (-)
C = Excitation (-)	F = Excitation (+)

MECHANICAL

Overload Capacity: 1,200 lbs (5,338 N)

Deflection of Sensor Beam: 0.005 in. max. (0.127 mm)

Material: 6061-T6, 7075-T6 Aluminum;
303, 304 Stainless Steel

Connector Positions (by mounting type):

Screw, Flange & Piloted-Flange: 6:00, 12:00

Pillow-Block: 12:00, Rear

Through-Frame: Rear

Load Ratings: 10, 25, 50, 100, 200, 400 lbs
(45, 111, 222, 445, 890, 1,779 N)

Wheel Weights:

Filament = 0.49 lb (222 g)

Ribbon = 0.45 lb (204 g)

Adapter = 0.65 lb (295 g)

SELECTION OF LOAD RATING

The correct transducer load rating for your application is determined by maximum web tension, wrap angle, and roller weight. Choose the appropriate wrap configuration from the diagrams below. Then compute the Net Force using the formula below the diagram. (The direction of the tension force determines which diagram and formula to use).

The selected load rating, may be 20% less than the computed Net Force. The actual force on the transducer will read 125% of the load rating before hitting the stops. This is acceptable because the Net Force formula contains an oversizing factor of 2, which means that the actual force exerted on the transducer will not exceed its rating.

Sometimes, the roller is so heavy that its weight uses up most of the operating range of the transducer.

When this happens, it may not be possible to adjust the tension indicating meter to read zero when tension is zero because the adjustment range of the electronic circuit has been exceeded. To find out if the roller is too heavy, compare the load rating with the effective weight of the roller as follows: The effective roller weight is the "WCOS(A)" term in the formula. If WCOS(A) is more than 95% of the load rating chosen, the tension meter will probably not be adjustable to zero. If this is the case, one or more of the following changes must be made to reduce WCOS(A) to less than 95% of the load rating:

1. Reduce the transducer roller or wheel weight.
2. Increase angle (A).
3. Use the next higher load rating (This is the least desirable choice because it reduces transducer signal output).

CONTINUE TO PAGE 4

WRAP 1

Tension Force (F_T) **Above** Horizontal

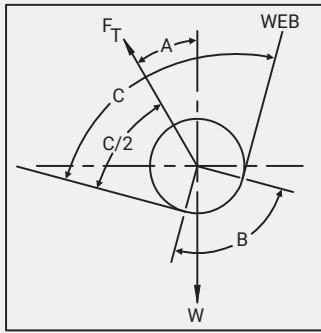

$$\text{NET FORCE} = 4T \sin\left(\frac{B}{2}\right) - W \cos(A)$$

WRAP 2

Tension Force (F_T) **Below** Horizontal

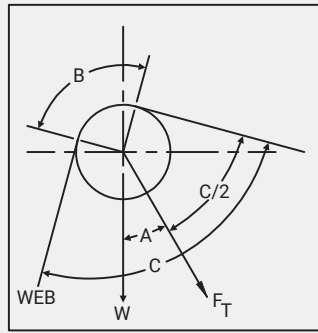

$$\text{NET FORCE} = 4T \sin\left(\frac{B}{2}\right) + W \cos(A)$$

W = Idler Roll Weight, **T** = Maximum Web Tension,
B = Wrap Angle = $180^\circ - C^\circ$, **A** = Angle Between Tension Force (F_T) and Vertical

TABLE 1

ANGLE	SINE	COSINE
0°	0.000	1.000
5°	0.087	0.996
10°	0.174	0.985
15°	0.259	0.966
20°	0.342	0.940
25°	0.423	0.906
30°	0.500	0.866
35°	0.574	0.819
40°	0.643	0.766
45°	0.707	0.707
50°	0.766	0.643
55°	0.819	0.574
60°	0.866	0.500
65°	0.906	0.423
70°	0.940	0.342
75°	0.966	0.259
80°	0.985	0.174
85°	0.996	0.087
90°	1.000	0.000

NOTE 1: Weight of standard filament wheel is 0.49 lb (222 grams) including bearings and fasteners.
 Weight of standard ribbon wheel is 0.45 lb (204 grams) including bearings and fasteners.
 Weight of standard adapter wheel is 0.65 lb (295 grams) including bearings and fasteners.
 Weight of customer supplied wheel must be provided and is subject to DFE engineering approval.

NOTE 2: These sizing formulas contain an oversizing factor of 2X tension to account for tension surges.

DIMENSIONS

inches (mm)

MOUNTING STYLE S

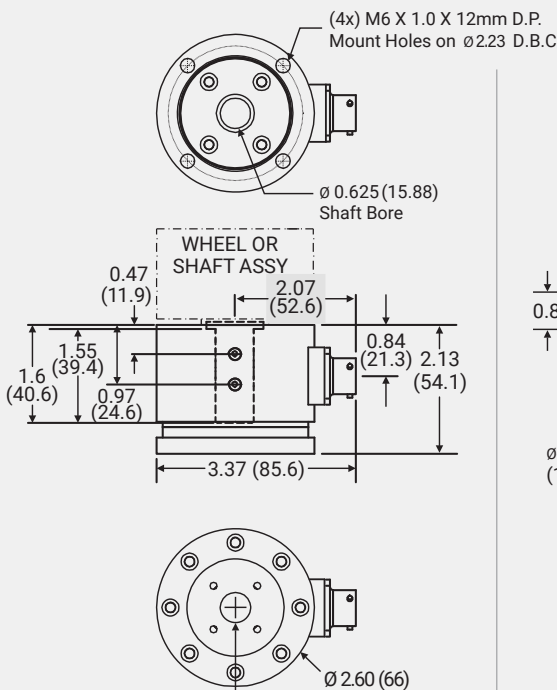

Standard 1/2-13 UNC mounting thread.
 Select MMS option for M12 x 1.75 thread.

MOUNTING STYLE FL

Flange may be rotated but not removed.

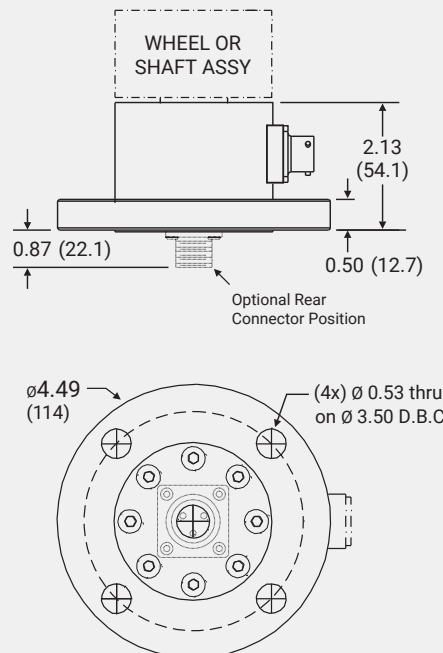

MOUNTING STYLE PB

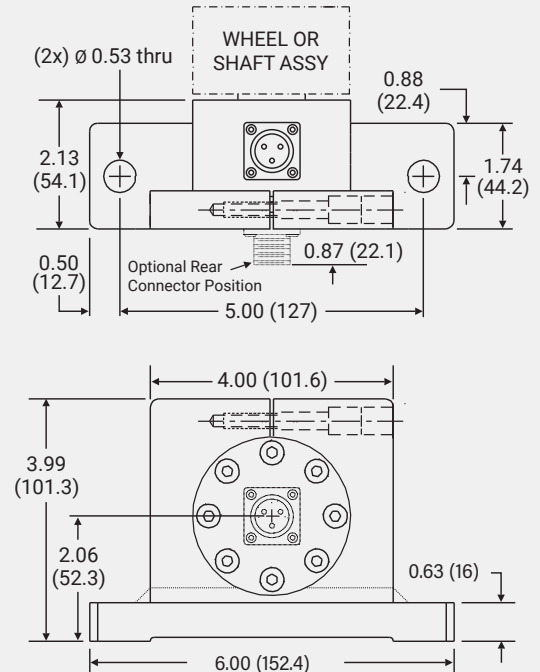

DIMENSIONS (CONTINUED)

inches (mm)

MOUNTING STYLE TF
Rear connector only.

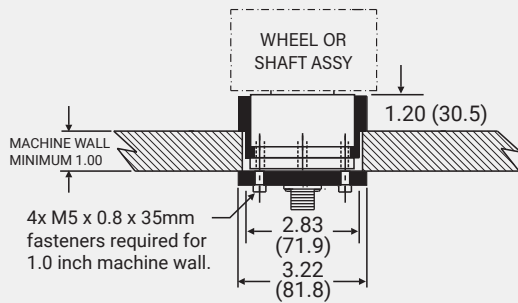

MOUNTING STYLE PFL

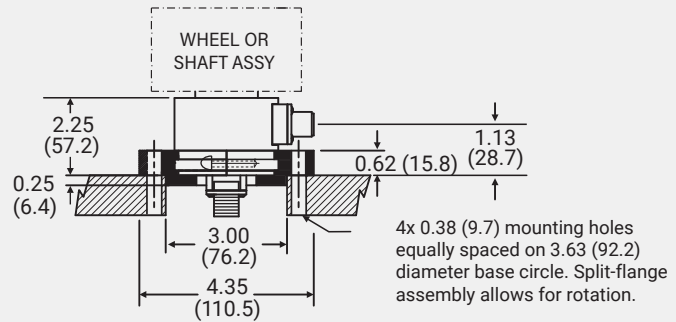

RIBBON WHEEL

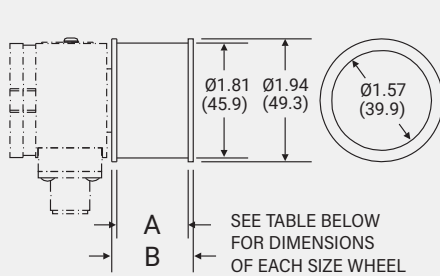

SEE TABLE BELOW FOR DIMENSIONS OF EACH SIZE WHEEL

FILAMENT WHEEL

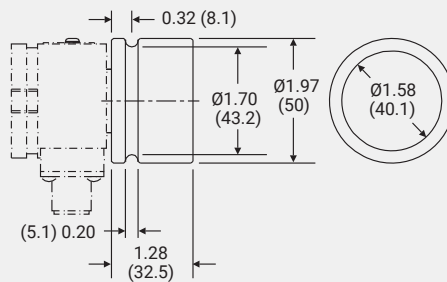

ADAPTER WHEEL

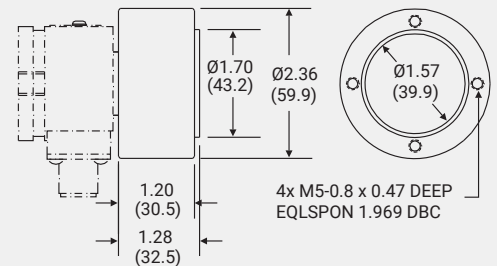

		RIBBON WHEEL SIZES			
		1	2	3	4
A	in.	1.13	2.13	3.13	4.13
	mm	28.7	54.1	79.5	104.9
B	in.	1.28	2.28	3.28	4.28
	mm	32.5	57.9	83.3	108.7

