

60 SERIES

The **60 Series Dual Disk Brake**, named for its **six inch** diameter disks, offers high performance in a **torque range from 3 lb-inches up to 1,010 lb-inches**.

The 60 Series Brake delivers the precise torque range needed for a particular application by allocating actuation of just the number of cylinders needed, from **one up to six**.

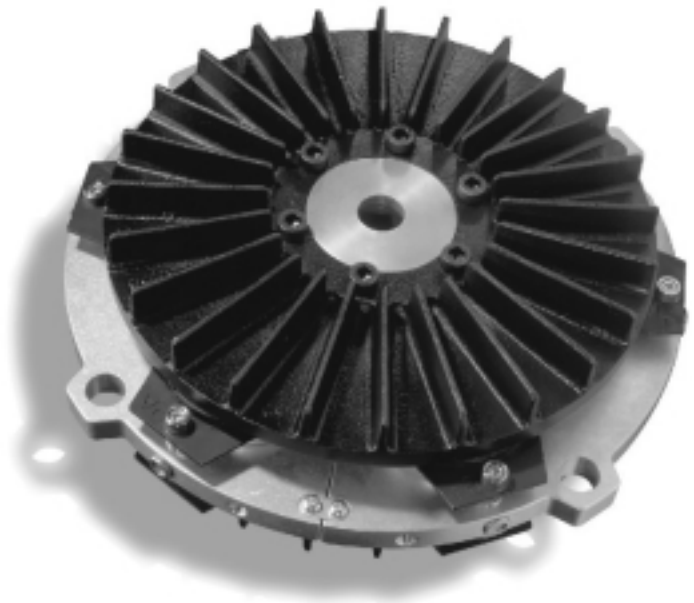

OPTIONS

- **Metric Mounting Bolt (MMB).** Metric mounting bolts for the actuators.
- **Non-Standard Key (NSK).** For shafts having a different sized key other than the standardized ones usually used.

ACCESSORIES

- **Mounting Plate** - Flat plate for mounting the brake and guard if used.
- **Guard** - Safety device to prevent people or objects from touching brake when in motion or hot.
- **Guard Blocks** - Allows installation of guard without mounting plate.
- **Valve Assembly** - Controls air supply for actuators.

SPECIFICATIONS:

Disk/Hub Inertia	2.54 Slug-in ²
Max. Torque	1,010 in-lbs
Disk/Hub Weight	9.1 lbs.
Max. Ship Wt.	22.5 lbs.
Min. Shaft Length	4.6 in.

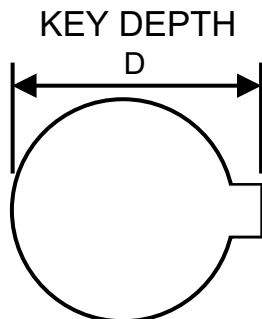

TORQUE CAPACITY, LB-IN (N-M)				
Torque Capacity at 75psi (5.17 bar)				
BRAKE SIZE		PAD COEFFICIENT OF FRICTION		
SERIES	# OF CYLINDERS	0.10 (#1) LB-IN (N-M)	0.20 (#2) LB-IN (N-M)	0.45 (#4) LB-IN (N-M)
60	1	40 (5)	80 (9)	170 (19)
	2	80 (9)	150 (17)	340 (38)
	3	110 (12)	230 (26)	500 (56)
	4	150 (17)	300 (34)	670 (76)
	5	190 (21)	380 (43)	840 (95)
	6	230 (26)	460 (52)	1010 (114)

STANDARD HUB BORE AND KEY DIMENSIONS						
	ENGLISH			METRIC		
	BORE	KEY	DEPTH (D)	BORE	KEY	DEPTH (D)
60	0.625	3/16	0.709	13	5	15.3
	0.688	3/16	0.773	14	5	16.3
	0.750	3/16	0.837	16	5	18.3
	0.813	3/16	0.900	18	6	20.8
	0.875	3/16	0.964	19	6	21.8
	0.938	1/4	1.051	20	6	22.8
S E R I E S	1.000	1/4	1.114	23	8	26.3
	1.063	1/4	1.178	25	8	28.3
	1.125	1/4	1.241	28	8	31.3
	1.188	1/4	1.304	30	8	33.3
	1.250	1/4	1.367	32	10	35.3
	1.313	5/16	1.455	35	10	38.3
	1.375	5/16	1.518			

60 SERIES DIMENSIONS (Model 66 shown)

inches (mm)

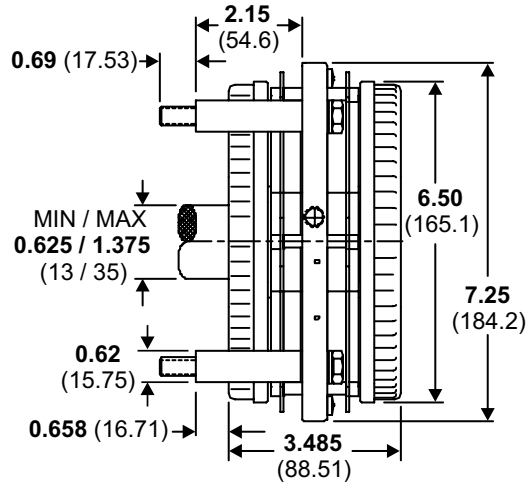
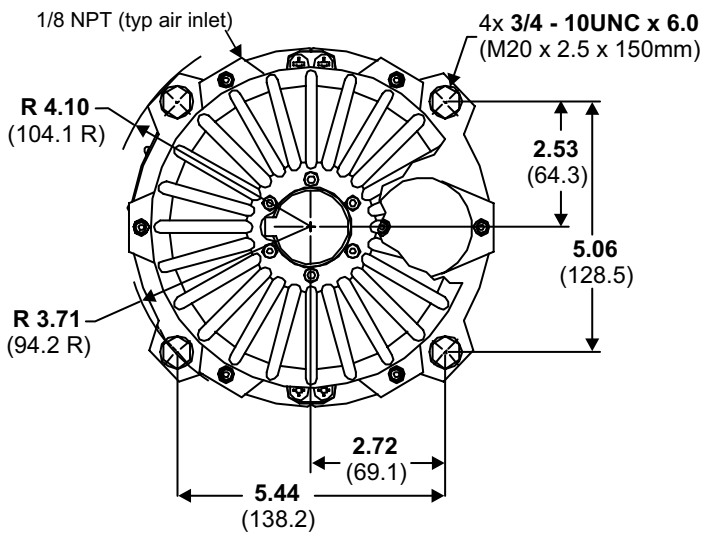

MOUNTING PLATE DIMENSIONS (Accessory)

inches (mm)

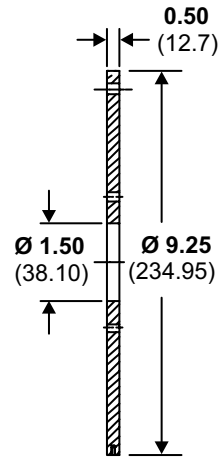
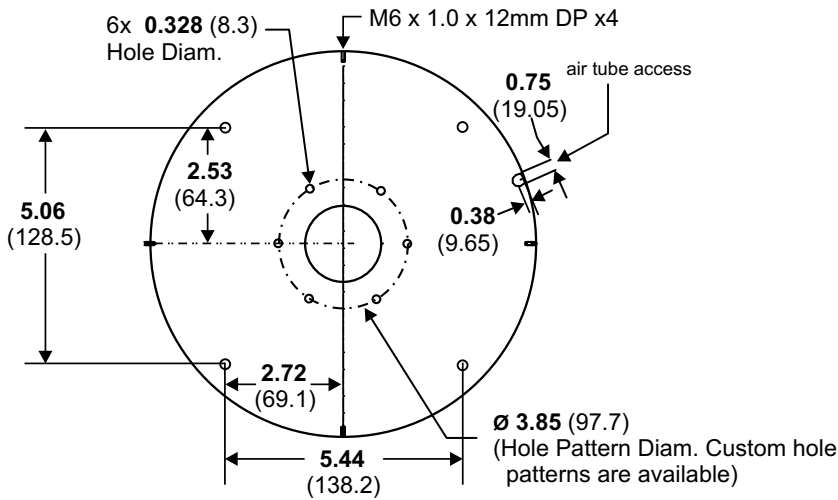

BRAKE GUARD DIMENSIONS (Accessory)

inches (mm)

THRU-SHAFT HOLE 2.00 (38.10) Diam.
REQUIRES REMOVAL OF NAME PLATE

