



WebHandler™ 3 AUTOMATIC DIGITAL TENSION CONTROLLER

The compact WebHandler™ 3 Tension Controller combines automated closed-loop process tension control with an easy-to-use touch-pad interface. The WebHandler™ 3 maintains a pre-selected tension set point on a web machine or press by measuring web tension from a tension transducer, then sending a compensating signal to a tensioning device such as a pneumatic brake, clutch or a DC drive. This closed-loop capability improves process consistency and productivity.

The large, two-line backlit LCD display reads out menu items, controller status and input prompts for use during setup and operating adjustment. Features include touch-pad setup and calibration, job setup storage and recall, and LCD scroll-through of an array of simple-to-activate functions including push-button rezero. The controller features soft start and bumpless auto/manual switching. It also automatically compensates for speed changes, roll diameter changes and other factors to maintain desired tension. Ten different measurement units are available for expressing a tension reading on the digital display.

Operation of the WebHandler™ 3 requires no special skills or training. The controller may be used in unwind, rewind or intermediate tension zones. A variety of controller output modes is available for operating pneumatic or electric brakes and clutches, eddy current clutches, and



DC and AC drives:

Pneumatic output: Used to actuate any air operated brake or clutch. The standard version includes a servo valve, air filter, and pressure regulator installed in an open back enclosure. These modules are designated **Version P**.

High Voltage output: Uses Silicon Controlled Rectifiers (SCR's) to produce a standard variable voltage of up to 90Vdc to operate any electric brake or clutch, including eddy current clutches. These modules are designated **Version V**.

0-10Volt DC output: Used to control DC drives or other variable speed drive systems. This output can be isolated from earth ground to make it more compatible with all drives. These output modules are designated **Version D**.

FEATURES:

- 0-10Vdc output (proportional to tension)
- Automatic and Manual control modes
- Emergency Stop
- Soft Start

OPTIONS:

- **230 Volt Power (230).**
- **24Vdc or 45Vdc Output (24V,45V).**
- **Attached Power Cord. (APC).**
- **Extended Range (XRE).** Allows extra sensitivity at low tension. Transducers must have XR option also.
- **+0-10Vdc OR 4-20mA Isolated Output (I10,I420).** Output which is not connected to circuit common, or to earth ground.
- **Metric Pneumatic Fittings (MPF).** "P" Version only.
- **Non-Standard Meter Scale (NMS).**
- **Remote Tension Amplifier (RTA).** Tension signal is provided by an external device.
- **Remote Tension Switch (RTS).** Tension On/Off switch installed in remote enclosure, usually with servo valve. "P" Version only.

- RS232 Serial Communications Port
- Tension meter damping
- High & Low Tension Limit Switch

- **Reverse Output (RO).** Increases output when tension exceeds set point, and decreases when tension drops below set point. Used in intermediate applications where transducers are located after the nip rolls being controlled by the transducers or for driven unwinds.
- **RS485** RS485 Serial Connection.
- **Speed Follow (SFD, SFP).** Accepts line speed signal from either a DC tach or pulse tach.
- **Taper Tension (TTD, TTF, TTP)** Tapers tension as roll size increases. Works with signal supplied by follower roll, DC or pulse tach.



SPECIFICATIONS

Power input:

P & D: 115/230 Volts 60/50Hz single phase @ 1 Amp

V: 115/230 Volts 60/50Hz single phase @ 6 Amps

Output:

P = 2 to 75 psi (0.14 to 5.17 bar)

V = 90, 45, or 24 Vdc, all @ 5 Amp w/115 Vac in

OR

90 Vdc, 45 Vdc all @ 5 Amp w/230 Vac in

D = 0 to ±10 Vdc, Compensated (Optional Isolated)

P, V, D = Choice of 0-10Vdc or 0-1mA tension indication to external device.

Enclosure: Steel, powder resin painted, NEMA 1

Weight: 9 lbs. (4.1 kg)

Transducer Signal Accepted:

500 mVdc per pair at rated load (1000 mV with XR option)

Mating Transducer Cable Connectors:

Amphenol MS3106A-10SL-3S

Zero (Tare) Range: 95% of transducer rating, minimum

Calibration Range: 25:1 max.

Temperature Range: 32° F to 104° F (0° C to 40° C)

System Accuracy: within 1 - 3% typical

Output Range: 0-100% Max.

Manual Mode Output Range: 0-100% of rated output

Standard Tension Ranges:

0 - 1, 5, 10, 25, 50, 100, 150, 250, 500, 1000, 1500, 2000, 2500, 3000

Taper Tension Range (option): 0-100%

Taper Tension by Rider Roll / Diameter Sensor:

0-10 Vdc input

Pneumatic Enclosure:

Input: 125 psi Max.

Output: 2 to 75 psi (0.14 to 5.17 bar)

Servo Valve Drive Signal: 4-20mA

Air Connections: In = 3/8" push fitting,

Out = 1/4" push fitting

Weight: 2.84 lbs. (1.28 kg.)

DIMENSIONS

inches (mm)

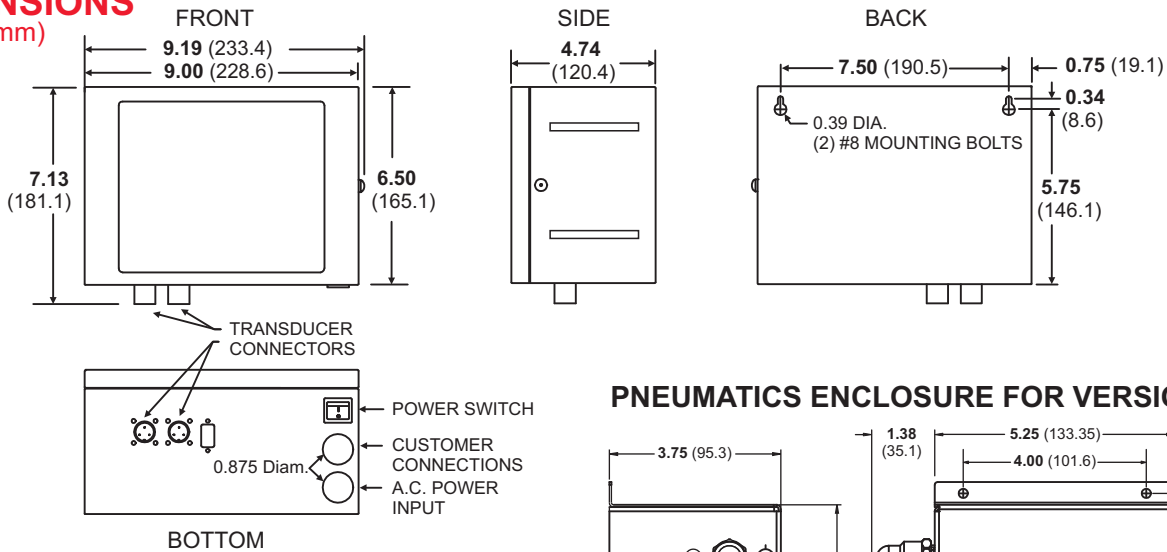

PNEUMATICS ENCLOSURE FOR VERSION P

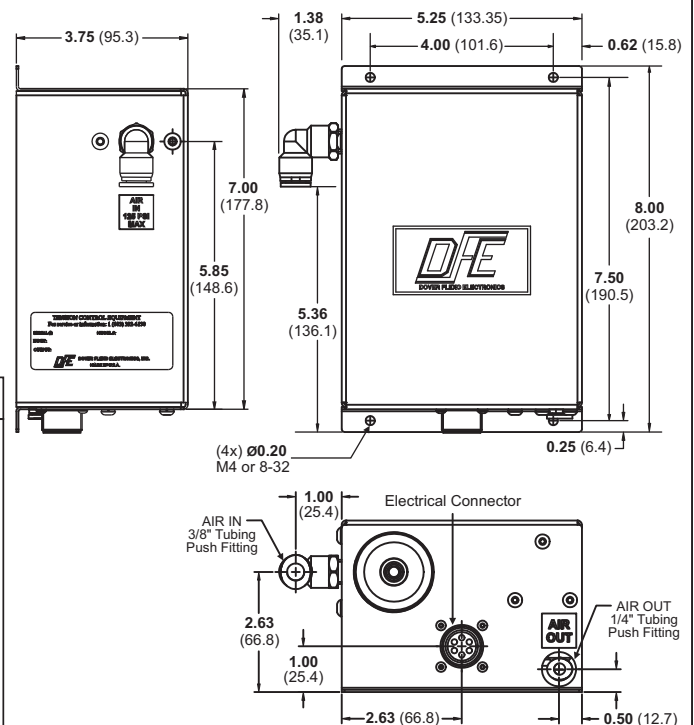

ORDERING INFO

You may order by description or by indicating your feature choices in place of the X's in the product code shown below.

Example: WH3P-U-100-RS48, RTA

WH3 X - X - XXXX - OPTIONS (Separated by commas)

OUTPUT	ZONE	METER SCALE	OPTIONS
P = Pneumatic V = Electric D = Drive C = Various	U = Unwind R = Rewind I = Intermediate	1 = 0-1 5 = 0-5 10 = 0-10 25 = 0-25 50 = 0-50 75 = 0-75 100 = 0-100 150 = 0-150 200 = 0-200 250 = 0-250 300 = 0-300 500 = 0-500 1000 = 0-1000 1500 = 0-1500 2000 = 0-2000 2500 = 0-2500 3000 = 0-3000	230 = 230 Volt Power Input 24 = 24 Vdc Output ¹ 45 = 45 Vdc Output ¹ APC = Attached Power Cord I10 = Isolated 10V Output I420 = 4-20mA Output MPF = Metric Pneumatic Fittings NMS = Non-Standard Meter Scale RO = Reverse Output RS48 = RS485 Interface RTA = Remote Tension Amplifier RTS = Remote Tension Switch ² SFD = Line Speed Follow SFP = Speed Follow by Pulse Tach TTD = Taper Tension by DC Tach TTF = Taper Tension by Diameter Follower TTP = Taper Tension by Pulse Tach XRE = Extended Range ³ Z = Special (SPR)

Notes: 1. "V" version only. 2. "P" version only. 3. Transducers must have XR option.